

54ABT/74ABT16794C 18-Bit Register with Readback

General Description

The ABT16794C is an 18-bit register with readback capability designed to store data as well as read the register information back onto the data bus. Each 9-bit byte, D_0 – D_8 , or D_9 – D_{17} , functions identically but independent of each other. The I/O bus (D bus) has TRI-STATE® outputs. Current sinking capability is 64 mA on both the D and Q busses.

Data is loaded into the registers on the low-to-high transition of the clock (CP). The output enable (\overline{OE}) is used to enable data on D_0 – D_7 . When \overline{OE} is low, the output of the registers is enabled on D_0 – D_7 , enabling D as an output bus. When \overline{OE} is high, D_0 – D_7 are inputs to the registers configuring D as an input bus.

Features

- Outputs sink capability of 64 mA, source capability of 32 mA
- Guaranteed latching protection
- High impedance glitch free bus loading during entire power up and power down cycle
- Non-destructive hot insertion capability

Ordering Code: See Section 10

Logic Symbol

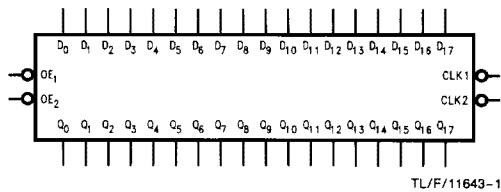

Connection Diagram

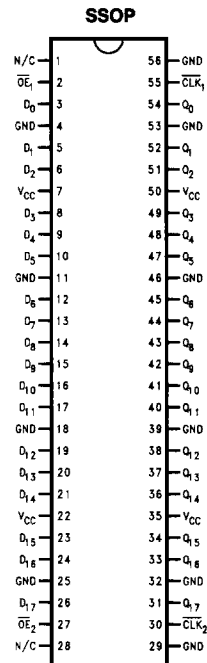

Pin Description

Pin Names	Description
\overline{OE}	Output Enable Inputs
CLK	Clock Pulse Inputs
D_0 – D_{17}	D Bus Inputs/ TRI-STATE Outputs
Q_0 – Q_{17}	Q Bus Outputs

TL/F/11643-2

Truth Tables

Inputs		Outputs	
CP	\overline{OE}	Q	D
L or H or ↓	L	Q_n	Output, Q
L or H or ↓	H	Q_n	Input
↑	L	Q_n	Output, Q^*
↑	H	D	Input

*In this case the output of the register is clocked to the inputs and the overall Q output is unchanged at Q_n .

Logic Diagram

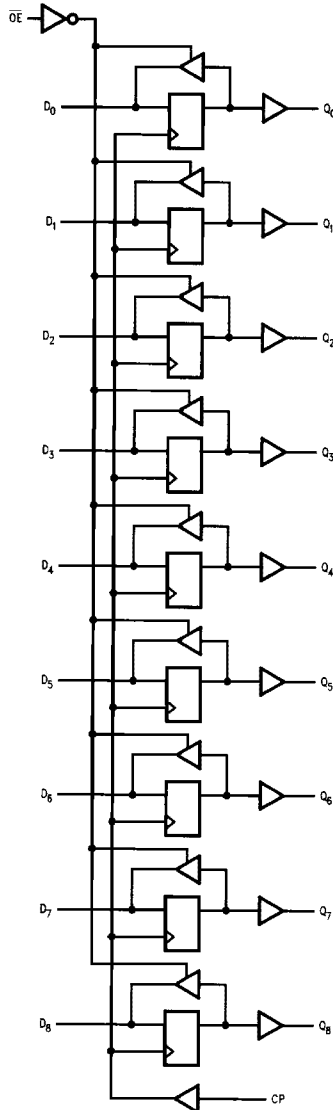

Similar for D9-D17 and Q8-Q17.

TL/F/11643-5

Absolute Maximum Ratings (Note 1)

If Military/Aerospace specified devices are required, please contact the National Semiconductor Sales Office/Distributors for availability and specifications.

Storage Temperature	-65°C to +150°C
Ambient Temperature under Bias	-55°C to +125°C
Junction Temperature under Bias	
Ceramic	-55°C to +175°C
Plastic	-55°C to +150°C
V _{CC} Pin Potential to Ground Pin	-0.5V to +7.0V
Input Voltage (Note 2)	-0.5V to +7.0V
Input Current (Note 2)	-30 mA to +5.0 mA
Voltage Applied to Any Output in the Disabled or Power-off State	-0.5V to 5.5V
in the HIGH State	-0.5V to V _{CC}
Current Applied to Output in LOW State (Max)	twice the rated I _{OL} (mA)

DC Latchup Source Current	-500 mA
Over Voltage Latchup (I/O)	10V

Note 1: Absolute maximum ratings are values beyond which the device may be damaged or have its useful life impaired. Functional operation under these conditions is not implied.

Note 2: Either voltage limit or current limit is sufficient to protect inputs.

Recommended Operating Conditions

Free Air Ambient Temperature	
Military	-55°C to +125°C
Commercial	-40°C to +85°C
Supply Voltage	
Military	+4.5V to +5.5V
Commercial	+4.5V to +5.5V
Minimum Input Edge Rate	($\Delta V/\Delta t$)
Data Input	50 mV/ns
Enable Input	20 mV/ns

DC Electrical Characteristics

Symbol	Parameter	ABT16794C			Units	V _{CC}	Conditions
		Min	Typ	Max			
V _{IH}	Input HIGH Voltage	2.0			V		Recognized HIGH Signal
V _{IL}	Input LOW Voltage			0.8	V		Recognized LOW Signal
V _{CD}	Input Clamp Diode Voltage			-1.2	V	Min	I _{IN} = -18 mA
V _{OH}	Output HIGH Voltage	54ABT/74ABT	2.5		V	Min	I _{OH} = -3 mA
		54ABT	2.0		V	Min	I _{OH} = -24 mA
		74ABT	2.0		V	Min	I _{OH} = -32 mA
V _{OL}	Output LOW Voltage	54ABT		0.55	V	Min	I _{OL} = 48 mA
		74ABT		0.55	V	Min	I _{OL} = 64 mA
I _{IH}	Input HIGH Current			5	μA	Max	V _{IN} = 2.7V (Note 1) V _{IN} = V _{CC}
I _{BVI}	Input HIGH Current Breakdown Test			7	μA	Max	V _{IN} = 7.0V
I _{IL}	Input LOW Current			-5	μA	Max	V _{IN} = 0.5V (Note 1) V _{IN} = 0.0V
V _{ID}	Input Leakage Test	4.75			V	0.0	I _{ID} = 1.9 μA All Other Pins Grounded
I _{OZH}	Output Leakage Current			50	μA	0 - 5.5V	V _{OUT} = 2.7V; \overline{OE}_n = 2.0V
I _{OZL}	Output Leakage Current			-50	μA	0 - 5.5V	V _{OUT} = 0.5V; \overline{OE}_n = 2.0V
I _{OS}	Output Short-Circuit Current	-100		-275	mA	Max	V _{OUT} = 0.0V
I _{CEx}	Output High Leakage Current			50	μA	Max	V _{OUT} = V _{CC}
I _{ZZ}	Bus Drainage Test			100	μA	0.0	V _{OUT} = 5.5V All Other Pins GND
I _{CCH}	Power Supply Current			100	μA	Max	All Outputs HIGH
I _{CCL}	Power Supply Current			60	mA	Max	All Outputs LOW
I _{CCZ}	Power Supply Current			100	μA	Max	\overline{OE}_n = V _{CC} All Others at V _{CC} or GND
I _{CCT}	Additional I _{CC} /Input	Outputs Enabled	2.5		mA	Max	V _I = V _{CC} - 2.1V Enable Input V _I = V _{CC} - 2.1V Data Input V _I = V _{CC} - 2.1V All Others at V _{CC} or GND
		Outputs TRI-STATE	2.5		mA		
		Outputs TRI-STATE	50		μA		
I _{CCD}	Dynamic I _{CC} (Note 1)	No Load		0.1	mA/MHz	Max	Outputs Open, \overline{OE}_n = GND One Bit Toggling, 50% Duty Cycle

Note 1: Guaranteed but not tested.

AC Electrical Characteristics: See Section 2 for Waveforms

Symbol	Parameter	74ABT		54ABT		74ABT		Units	Fig. No.		
		$T_A = +25^\circ\text{C}$ $V_{CC} = +5\text{V}$ $C_L = 50\text{ pF}$		$T_A = -55^\circ\text{C to } +125^\circ\text{C}$ $V_{CC} = 4.5\text{V}-5.5\text{V}$ $C_L = 50\text{ pF}$		$T_A = -40^\circ\text{C to } +85^\circ\text{C}$ $V_{CC} = 4.5\text{V}-5.5\text{V}$ $C_L = 50\text{ pF}$					
		Min	Typ	Max	Min	Max	Min			Max	
t_{PLH} t_{PHL}	Propagation Delay Data to Outputs	1.0		3.9				1.0	3.9	ns	2-3, 5
t_{PZH} t_{PZL}	Output Enable Time	1.5		6.3				1.5	6.3	ns	2-4
t_{PHZ} t_{PLZ}	Output Disable Time	1.0		6.7				1.0	6.7	ns	2-4

Capacitance

Symbol	Parameter	Typ	Units	Conditions $T_A = 25^\circ\text{C}$
C_{IN}	Input Capacitance	5.0	pF	$V_{CC} = 5.0\text{V}$
C_{OUT} (Note 1)	Output Capacitance	9.0	pF	$V_{CC} = 5.0\text{V}$

Note 1: C_{OUT} is measured at frequency $f = 1\text{ MHz}$; per MIL STD-883B, Method 3012.