

FlatPAC™

50 to 600W
Autoranging
AC-DC Switchers

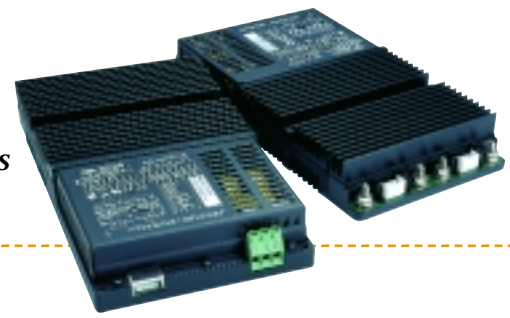

Product Highlights

If you're looking for the convenience of a complete, low profile, agency-approved switching power supply, look no further. The FlatPAC combines Vicor's workhorse VI-200 family of DC-DC converters with a modular package and front end subassembly to provide from 50 to 600W of output power from one to three outputs.

The FlatPAC's contemporary design allows us to configure your order quickly and provide rapid turnaround on standard models. It is truly a complete power solution, enabling you to spend more time designing your system and less time worrying about how to power it.

Conduction Cooled Models Available
Add "-CC" to the end of the part number

Features

- Microcontroller Architecture
- Inputs: 115/230Vac Autoranging
- FCC Part 15, Class B
EN55022, Class B
- 80-90% Efficiency
- Any Output: 1 to 95Vdc
- Module Enable/Disable (2&3 up)
- UL, CSA, TÜV, VDE, BABT, CE Marked
- Remote Sense and Current Limit
- BUS OK and AC OK (2&3 up)
- 40mS Ride-Through Time (typical)
- OVP and Thermal Shutdown
- 1-Up Models: 1 Output; Up to 200W
- 2-Up Models: 1 or 2 Outputs; Up to 400W
- 3-Up Models: 1, 2, or 3 Outputs; Up to 600W

FlatPAC Configuration Chart

Typical Model: VI-RU 011-EUUU

Input: 115/230Vac; Output 1: 5Vdc at 200W
Output 2: 12Vdc at 200W
Output 3: 12Vdc at 200W
Total Power Part No.

Dimensions

Configuration	Power Range	Model	Dimensions (L x W x H)
Single Outputs:	50-200W	VI-LU	9.25"L x 2.5"W x 1.37"H (234,8 x 63,5 x 34,8mm)
	200-400W	VI-MU	9.25"L x 4.9"W x 1.37"H (234,8 x 124,5 x 34,8mm)
	300-600W	VI-NU	9.25"L x 7.3"W x 1.37"H (234,8 x 185,4 x 34,8mm)
Dual Outputs:	100-400W	VI-PU	9.5"L x 4.9"W x 1.37"H (234,8 x 124,5 x 34,8mm)
	150-600W	VI-QU	9.25"L x 7.3"W x 1.37"H (234,8 x 185,4 x 34,8mm)
Triple Outputs:	150-600W	VI-RU	9.25"L x 7.3"W x 1.37"H (234,8 x 185,4 x 34,8mm)

Input Characteristics 90-132/180-264Vac U = Autoranging	Output Voltage Z = 2V 1 = 12V Y = 3.3V 2 = 15V O = 5V 3 = 24V M = 10V L = 28V 4 = 48V 1 to 95V, consult factory.	Product Grade E = 0°C to +85°C Case C = 0°C to +85°C Case I = -30°C to +85°C Case
Output Power/Current V _{out} ≥ 5V V _{out} < 5V Y = 50W Y = 10A X = 75W X = 15A W = 100W W = 20A V = 150W V = 30A U = 200W U = 40A	Output Power V _{out} ≥ 5V V _{out} < 5V W = 100W W = 20A V = 150W V = 30A U = 200W U = 40A S = 300W S = 60A Q = 400W Q = 80A	Output Power/Current V _{out} ≥ 5V V _{out} < 5V S = 300W S = 60A P = 450W P = 90A M = 600W M = 120A

FlatPAC Specifications

(Typical at 25°C, nominal line and 75% load, unless otherwise specified.)

Input Characteristics

AC Line Input	
Autoranging	90-132/180-264Vac
Line Frequency	47 to 63Hz (C-grade and E-grade) 47 to 440Hz (I-grade)
Inrush Current	
115Vac Operation	1 up: 16A @ peak line; 2 up: 23A @ peak line; 3 up: 39A @ peak line
230Vac Operation	1 up: 32A @ peak line; 2 up: 47A @ peak line; 3 up: 78A @ peak line
Ride-through Time (Full Load)	
90/180Vac Low Line	5ms minimum
115/230Vac Nominal Line	40ms minimum
AC Fail Warning Time	5ms minimum (low line, full load)
AC and BUS OK (2-up and 3-up models only)	
Off State	Vce = 70V maximum
On State	Vcesat = 0.4V maximum @ 1mA (1.5mA max.)
Module Disable (2-up and 3-up models only, optically isolated LED input)	
Continuous Forward Current	1 mA to 30mA
Forward Voltage	1.65V max. at 30mA
Conducted and Radiated EMI/RFI	EN 55022-B all models; 2 up/3 up: VDE 0871 Level B
Dielectric Withstand	
Primary to chassis GND	2121Vdc
Primary to secondary	4242Vdc
Secondary to chassis GND	707Vdc
Transient Surge	EN 61000-4-5

Output Characteristics (applies to each output individually)

	E-Grade			C-, I-Grade			UNITS	NOTES
	MIN.	TYP.	MAX.	MIN.	TYP.	MAX		
Setpoint accuracy		1%	2%		0.5%	1%	V _{NOM}	
Load/line regulation			0.5%		0.05%	0.2%	V _{NOM}	LL to HL, 10% to Full Load
Load/line regulation			1%		0.2%	0.5%	V _{NOM}	LL to HL, No Load to 10%
Output temperature drift		0.02			0.01	0.02	%/°C	Over rated temperature
Long term drift		0.02			0.02		%/1K hours	
Output ripple - pp:								
2V			150mV		60mV	100mV	p-p	20MHz bandwidth
5V			5%		2%	3%	p-p	20MHz bandwidth
10-48V			3%		0.75%	1.5%	p-p	20MHz bandwidth
Output voltage trimming ¹	50%		110%	50%		110%		
Total remote sense compensation ¹	0.5			0.5			Volts	0.25V max. neg. leg
OVP setpoint		125%		115%	125%	135%	V _{NOM}	Recycle power
Current limit	105%		135%	105%	125%	125%	I _{NOM}	Automatic restart
Short circuit current ²	20%		140%	20%		130%	I _{NOM}	

Thermal Characteristics

Efficiency		78-88%			80-90%			
Shutdown temp. — case	90	95	105	90	95	105	°C	Cool and recycle power to restart
Operating temp. — case			85			85	°C	See Thermal Curves

Mechanical Specifications

Weight ³	22.4 (652)	22.4 (652)	Ounces (Grams)
---------------------	------------	------------	----------------

Safety Agency Approvals

UL, CSA, TÜV, VDE, IEC 950, CE Marked

Environmental Characteristics/Product Grade Designators

Storage Temperature	-20°C to +100°C (C-grade and E-grade) -55°C to +100°C (I-grade)
Operating Temperature	0°C to +85°C (C-grade and E-grade)
Case	-30°C to +85°C (I-grade)

¹10, 12V and 15V outputs, trim range ±10%. Consult factory for wider trim range.

²Output voltages of 5V or less incorporate foldback current limiting, outputs of 10V and above incorporate straight line current limiting.

³For 2-up FlatPACs, multiply value by 2; for 3-up FlatPACs, multiply value by 3.

Thermal Curves, 5V Output

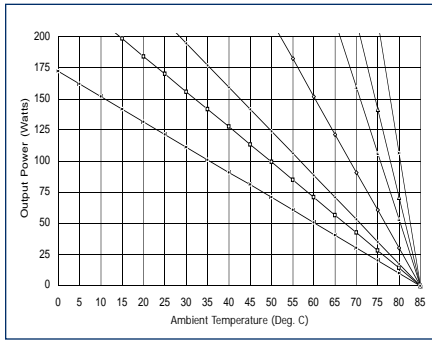
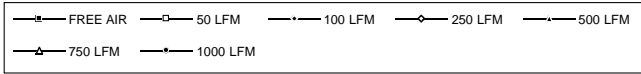

1 Up

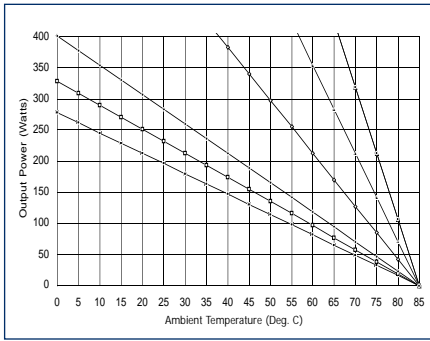

2 Up

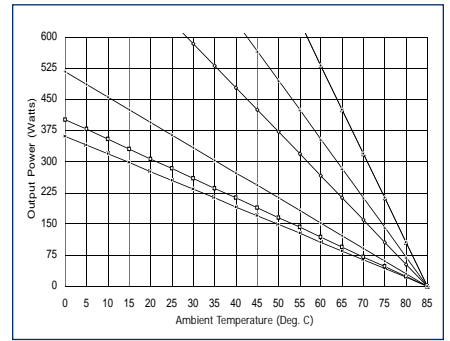

3 UP

Thermal Curves, 10 to 48V Output

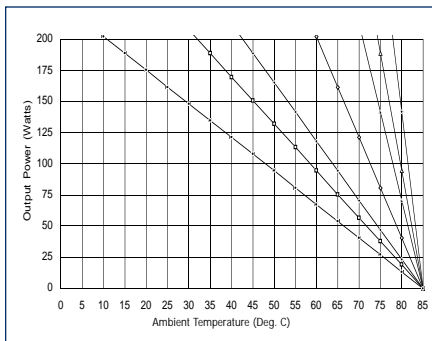
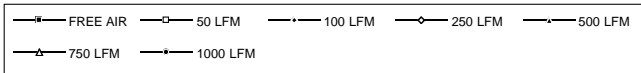

1 Up

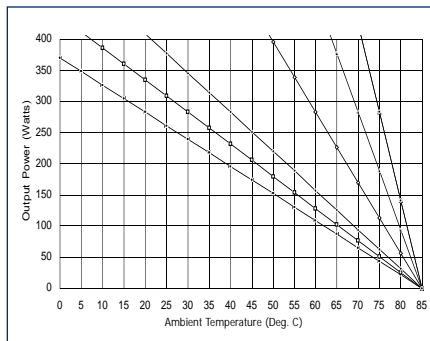

2 Up

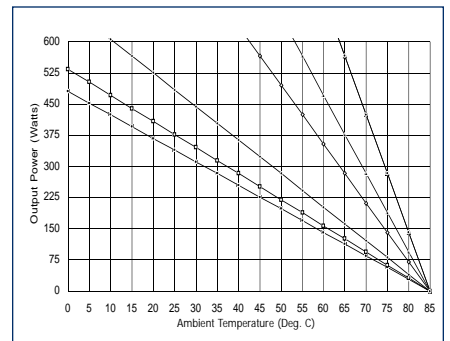

3 UP

Application Circuits

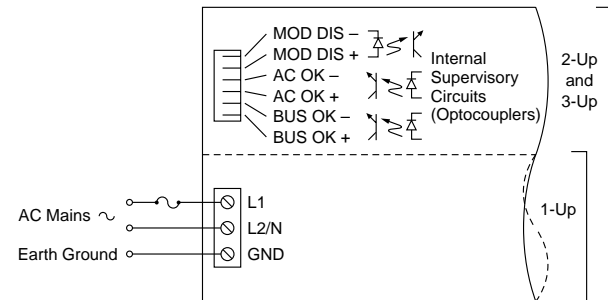

AC Mains Connections

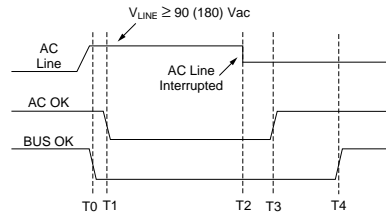

Conditions: Full Load 90 (180) Vac, AC Line

Time Interval	Min	Typ	Max	Units	Notes
T0-T1	0	0.1	1.0	ms	
T2-T3	0	-	-	ms	
T2-T4	5	-	-	ms	Ride-through time
T3-T4	5	-	-	ms	AC fail warning time

Power Up and Power Down Sequencing

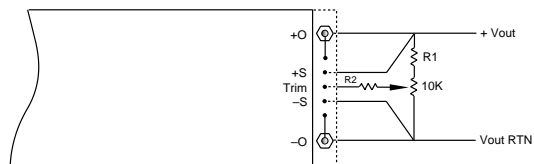

Resistor Values for Trimming Standard Output Voltages

Nom. Output Voltage	5V	12V	15V	24V	28V	48V	Trim Range
R1(kΩ)	.953	15.8	22.1	41.2	48.7	90.9	+10%, -10%
R2(kΩ)	90	90	90	90	90	90	

Output Trimming

Mechanical Drawings

Inputs

- 1 MOD DIS-
 - 2 MOD DIS+
 - 3 AC OK-
 - 4 AC OK+
 - 5 BUS OK-
 - 6 BUS OK+
 - 7 AC IN L1
 - 8 AC IN L2/N
 - 9 CHASSIS GND
- Input connector, Amp P/N 644488-6; mating connector, MTA-100 IDC Series
- Terminals for #16-12 AWG wire

Outputs

- 10 +OUT (#10-32 Stud)
 - 11 +OUT
 - 12 +SENSE (V_{TRIM}^*)
 - 13 TRIM (I_{TRIM}^*)
 - 14 -SENSE (I_{MON}^*)
 - 15 -OUT
 - 16 -OUT (#10-32 Stud)
- Output connector, Amp P/N 644486-5; mating connector, MTA-100 IDC Series

*On FlatPACs with BatMODs only.

All Models

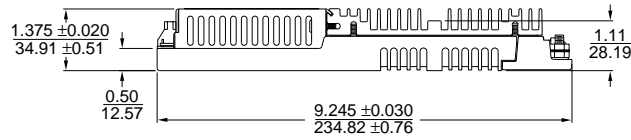

1-UP

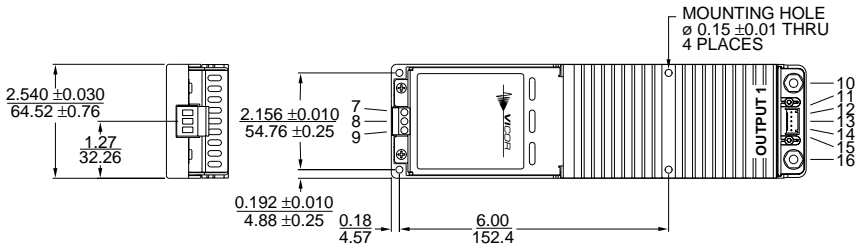

2-UP

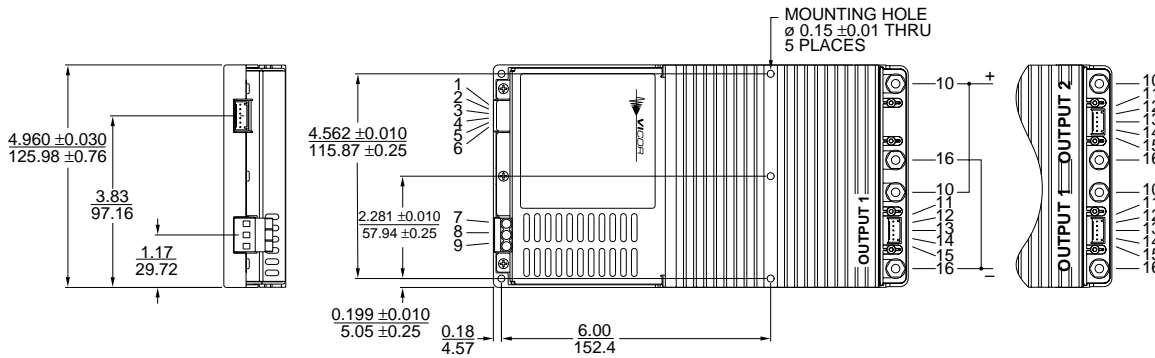

3-UP

