

260-Pin BGA
Com & Ind Temp
POD I/O

144Mb SigmaQuad-IVe™
Burst of 4 Multi-Bank ECCRAM™

Up to 1333 MHz
1.25V ~ 1.3V V_{DD}
1.2V ~ 1.3V V_{DDQ}

Features

- 4Mb x 36 and 8Mb x 18 organizations available
- Organized as 8 logical memory banks
- 1333 MHz maximum operating frequency
- 1.333 BT/s peak transaction rate (in billions per second)
- 192 Gb/s peak data bandwidth (in x36 devices)
- Separate I/O DDR Data Buses
- Non-multiplexed SDR Address Bus
- One operation - Read or Write - per clock cycle
- Certain address/bank restrictions on Read and Write ops
- Burst of 4 Read and Write operations
- 6 cycle Read Latency
- On-chip ECC with virtually zero SER
- Loopback signal timing training capability
- 1.25V ~ 1.3V nominal core voltage
- 1.2V ~ 1.3V POD I/O interface
- Configuration registers
- Configurable ODT (on-die termination)
- ZQ pin for programmable driver impedance
- ZT pin for programmable ODT impedance
- IEEE 1149.1 JTAG-compliant Boundary Scan
- 260-pin, 14 mm x 22 mm, 1 mm ball pitch, 6/6 RoHS-compliant BGA package

SigmaQuad-IVe™ Family Overview

SigmaQuad-IVe ECCRAMs are the Separate I/O half of the SigmaQuad-IVe/SigmaDDR-IVe family of high performance ECCRAMs. Although similar to GSI's third generation of networking SRAMs (the SigmaQuad-IIIE/SigmaDDR-IIIE family), these fourth generation devices offer several new features that help enable significantly higher performance.

Clocking and Addressing Schemes

The GS81314PD18/36GK SigmaQuad-IVe ECCRAMs are synchronous devices. They employ three pairs of positive and negative input clocks; one pair of master clocks, \overline{CK} and \overline{CK} , and two pairs of write data clocks, $\overline{KD}[1:0]$ and $\overline{KD}[1:0]$. All six input clocks are single-ended; that is, each is received by a dedicated input buffer.

\overline{CK} and \overline{CK} are used to latch address and control inputs, and to control all output timing. $\overline{KD}[1:0]$ and $\overline{KD}[1:0]$ are used solely to latch data inputs.

Each internal read and write operation in a SigmaQuad-IVe B4 ECCRAM is four times wider than the device I/O bus. An input data bus de-multiplexer is used to accumulate incoming data before it is simultaneously written to the memory array. An output data multiplexer is used to capture the data produced from a single memory array read and then route it to the appropriate output drivers as needed. Therefore, the address field of a SigmaQuad-IVe B4 ECCRAM is always two address pins less than the advertised index depth (e.g. the 8M x 18 has 2M addressable index).

On-Chip Error Correction Code

GSI's ECCRAMs implement an ECC algorithm that detects and corrects all single-bit memory errors, including those induced by SER events such as cosmic rays, alpha particles, etc. The resulting Soft Error Rate of these devices is anticipated to be <0.002 FITs/Mb — a 5-order-of-magnitude improvement over comparable SRAMs with no on-chip ECC, which typically have an SER of 200 FITs/Mb or more.

All quoted SER values are at sea level in New York City.

Parameter Synopsis

Speed Grade	Max Operating Frequency	Read Latency	V _{DD}
-133	1333 MHz	6 cycles	1.2V to 1.35V
-120	1200 MHz	6 cycles	1.2V to 1.35V
-106	1066 MHz	6 cycles	1.2V to 1.35V

8M x 18 Pinout (Top View)

	1	2	3	4	5	6	7	8	9	10	11	12	13
A	V _{DD}	NU _O	V _{DD}	NU _I	NC (RSVD)	MCH (CFG)	MRW	ZQ	PZT1	DINV0	V _{DD}	QINV0	V _{DD}
B	V _{SS}	NU _O	V _{SS}	NU _I	MCL	MCH (B4M)	NC (RSVD)	MCH (SIOM)	PZT0	D0	V _{SS}	Q0	V _{SS}
C	Q17	V _{DDQ}	D17	V _{DDQ}	V _{SS}	SA13	V _{DD}	SA14	V _{SS}	V _{DDQ}	NU _I	V _{DDQ}	NU _O
D	V _{SS}	NU _O	V _{SS}	NU _I	SA19	V _{DDQ}	NC (288 Mb)	V _{DDQ}	SA20	D1	V _{SS}	Q1	V _{SS}
E	Q16	V _{DDQ}	D16	V _{DD}	V _{SS}	SA11	V _{SS}	SA12	V _{SS}	V _{DD}	NU _I	V _{DDQ}	NU _O
F	V _{SS}	NU _O	V _{SS}	NU _I	SA17	V _{DD}	V _{DDQ}	V _{DD}	SA18	D2	V _{SS}	Q2	V _{SS}
G	Q15	NU _O	D15	NU _I	V _{SS}	SA9	NU _I	SA10	V _{SS}	D3	NU _I	Q3	NU _O
H	Q14	V _{DDQ}	D14	V _{DDQ}	SA15	V _{DDQ}	\bar{W}	V _{DDQ}	SA16	V _{DDQ}	NU _I	V _{DDQ}	NU _O
J	V _{SS}	NU _O	V _{SS}	NU _I	V _{SS}	SA7	V _{SS}	SA8	V _{SS}	D4	V _{SS}	Q4	V _{SS}
K	CQ1	V _{DDQ}	V _{REF}	V _{DD}	KD1	V _{DD}	CK	V _{DD}	KD0	V _{DD}	V _{REF}	V _{DDQ}	CQ0
L	$\overline{CQ1}$	V _{SS}	QVLD1	V _{SS}	$\overline{KD1}$	V _{DDQ}	\overline{CK}	V _{DDQ}	$\overline{KD0}$	V _{SS}	QVLD0	V _{SS}	$\overline{CQ0}$
M	V _{SS}	Q13	V _{SS}	D13	V _{SS}	SA5	V _{SS}	SA6	V _{SS}	NU _I	V _{SS}	NU _O	V _{SS}
N	NU _O	V _{DDQ}	NU _I	V _{DDQ}	PLL	V _{DDQ}	\bar{R}	V _{DDQ}	MCL	V _{DDQ}	D5	V _{DDQ}	Q5
P	NU _O	Q12	NU _I	D12	V _{SS}	SA3	MZT	SA4	V _{SS}	NU _I	D6	NU _O	Q6
R	V _{SS}	Q11	V _{SS}	D11	MCH	V _{DD}	V _{DDQ}	V _{DD}	RST	NU _I	V _{SS}	NU _O	V _{SS}
T	NU _O	V _{DDQ}	NU _I	V _{DD}	V _{SS}	SA1	V _{SS}	SA2	V _{SS}	V _{DD}	D7	V _{DDQ}	Q7
U	V _{SS}	Q10	V _{SS}	D10	NC (576 Mb)	V _{DDQ}	NC (RSVD)	V _{DDQ}	NC (1152 Mb)	NU _I	V _{SS}	NU _O	V _{SS}
V	NU _O	V _{DDQ}	NU _I	V _{DDQ}	V _{SS}	SA21 (x18)	V _{DD}	NU _I (B2)	V _{SS}	V _{DDQ}	D8	V _{DDQ}	Q8
W	V _{SS}	Q9	V _{SS}	D9	TCK	MCL	RCS	MCL	TMS	NU _I	V _{SS}	NU _O	V _{SS}
Y	V _{DD}	QINV1	V _{DD}	DINV1	TDO	NU	NC (RSVD)	MCL	TDI	NU _I	V _{DD}	NU _O	V _{DD}

Notes:

1. Pins 5B, 6W, 8W, 8Y, and 9N must be tied Low in this device.
2. Pin 5R must be tied High in this device.
3. Pin 6A is defined as mode pin CFG in the pinout standard. It must be tied High in this device to select x18 configuration.
4. Pin 6B is defined as mode pin B4M in the pinout standard. It must be tied High in this device to select Burst-of-4 configuration.
5. Pin 8B is defined as mode pin SIOM in the pinout standard. It must be tied High in this device to select Separate I/O configuration.
6. Pin 6V is defined as address pin SA for x18 devices. It is used in this device.
7. Pin 8V is defined as address pin SA for B2 devices. It is unused in this device, and must be left unconnected or driven High.
8. Pin 7D is reserved as address pin SA for 288 Mb devices. It is a true no connect in this device.
9. Pin 5U is reserved as address pin SA for 576 Mb devices. It is a true no connect in this device.
10. Pin 9U is reserved as address pin SA for 1152 Mb devices. It is a true no connect in this device.

4M x 36 Pinout (Top View)

	1	2	3	4	5	6	7	8	9	10	11	12	13
A	V _{DD}	QINV3	V _{DD}	DINV3	NC (RSVD)	MCL (CFG)	MRW	ZQ	PZT1	DINV0	V _{DD}	QINV0	V _{DD}
B	V _{SS}	Q35	V _{SS}	D35	MCL	MCH (B4M)	NC (RSVD)	MCH (SIOM)	PZT0	D0	V _{SS}	Q0	V _{SS}
C	Q26	V _{DDQ}	D26	V _{DDQ}	V _{SS}	SA13	V _{DD}	SA14	V _{SS}	V _{DDQ}	D9	V _{DDQ}	Q9
D	V _{SS}	Q34	V _{SS}	D34	SA19	V _{DDQ}	NC (288 Mb)	V _{DDQ}	SA20	D1	V _{SS}	Q1	V _{SS}
E	Q25	V _{DDQ}	D25	V _{DD}	V _{SS}	SA11	V _{SS}	SA12	V _{SS}	V _{DD}	D10	V _{DDQ}	Q10
F	V _{SS}	Q33	V _{SS}	D33	SA17	V _{DD}	V _{DDQ}	V _{DD}	SA18	D2	V _{SS}	Q2	V _{SS}
G	Q24	Q32	D24	D32	V _{SS}	SA9	NU _I	SA10	V _{SS}	D3	D11	Q3	Q11
H	Q23	V _{DDQ}	D23	V _{DDQ}	SA15	V _{DDQ}	\bar{W}	V _{DDQ}	SA16	V _{DDQ}	D12	V _{DDQ}	Q12
J	V _{SS}	Q31	V _{SS}	D31	V _{SS}	SA7	V _{SS}	SA8	V _{SS}	D4	V _{SS}	Q4	V _{SS}
K	CQ1	V _{DDQ}	V _{REF}	V _{DD}	KD1	V _{DD}	CK	V _{DD}	KD0	V _{DD}	V _{REF}	V _{DDQ}	CQ0
L	$\overline{CQ1}$	V _{SS}	QVLD1	V _{SS}	$\overline{KD1}$	V _{DDQ}	\overline{CK}	V _{DDQ}	$\overline{KD0}$	V _{SS}	QVLD0	V _{SS}	$\overline{CQ0}$
M	V _{SS}	Q22	V _{SS}	D22	V _{SS}	SA5	V _{SS}	SA6	V _{SS}	D13	V _{SS}	Q13	V _{SS}
N	Q30	V _{DDQ}	D30	V _{DDQ}	PLL	V _{DDQ}	\bar{R}	V _{DDQ}	MCL	V _{DDQ}	D5	V _{DDQ}	Q5
P	Q29	Q21	D29	D21	V _{SS}	SA3	MZT	SA4	V _{SS}	D14	D6	Q14	Q6
R	V _{SS}	Q20	V _{SS}	D20	MCH	V _{DD}	V _{DDQ}	V _{DD}	RST	D15	V _{SS}	Q15	V _{SS}
T	Q28	V _{DDQ}	D28	V _{DD}	V _{SS}	SA1	V _{SS}	SA2	V _{SS}	V _{DD}	D7	V _{DDQ}	Q7
U	V _{SS}	Q19	V _{SS}	D19	NC (576 Mb)	V _{DDQ}	NC (RSVD)	V _{DDQ}	NC (1152 Mb)	D16	V _{SS}	Q16	V _{SS}
V	Q27	V _{DDQ}	D27	V _{DDQ}	V _{SS}	NU _I (x18)	V _{DD}	NU _I (B2)	V _{SS}	V _{DDQ}	D8	V _{DDQ}	Q8
W	V _{SS}	Q18	V _{SS}	D18	TCK	MCL	RCS	MCL	TMS	D17	V _{SS}	Q17	V _{SS}
Y	V _{DD}	QINV2	V _{DD}	DINV2	TDO	NU	NC (RSVD)	MCL	TDI	DINV1	V _{DD}	QINV1	V _{DD}

Notes:

1. Pins 5B, 6W, 8W, 8Y, and 9N must be tied Low in this device.
2. Pin 5R must be tied High in this device.
3. Pin 6A is defined as mode pin CFG in the pinout standard. It must be tied Low in this device to select x36 configuration.
4. Pin 6B is defined as mode pin B4M in the pinout standard. It must be tied High in this device to select Burst-of-4 configuration.
5. Pin 8B is defined as mode pin SIOM in the pinout standard. It must be tied High in this device to select Separate I/O configuration.
6. Pin 6V is defined as address pin SA for x18 devices. It is unused in this device, and must be left unconnected or driven High.
7. Pin 8V is defined as address pin SA for B2 devices. It is unused in this device, and must be left unconnected or driven High.
8. Pin 7D is reserved as address pin SA for 288 Mb devices. It is a true no connect in this device.
9. Pin 5U is reserved as address pin SA for 576 Mb devices. It is a true no connect in this device.
10. Pin 9U is reserved as address pin SA for 1152 Mb devices. It is a true no connect in this device.

Pin Description

Symbol	Description	Type
SA[21:1]	Address — Read or write address is registered on $\uparrow\text{CK}$.	Input
D[35:0]	Write Data — Registered on $\uparrow\text{KD}$ and $\uparrow\overline{\text{KD}}$ during Write operations. D[17:0] - x18 and x36. D[35:18] - x36 only.	Input
DINV[3:0]	Write Data Inversion — Registered on $\uparrow\text{KD}$ and $\uparrow\overline{\text{KD}}$ (along with write data) during Write operations. Indicate if the associated write data byte is inverted (DINVx = 1) or not (DINVx = 0). DINV0 - associated with D[8:0] in x18 and x36. DINV1 - associated with D[17:9] in x18 and x36. DINV2 - associated with D[26:18] in x36 only. DINV3 - associated with D[35:27] in x36 only. Note: Treated as NU inputs when Data Inversion is disabled.	Input
Q[35:0]	Read Data — Aligned with $\uparrow\text{CQ}$ and $\uparrow\overline{\text{CQ}}$ during Read operations. Q[17:0] - x18 and x36. Q[35:18] - x36 only.	Output
QINV[3:0]	Read Data Inversion — Aligned with $\uparrow\text{CQ}$ and $\uparrow\overline{\text{CQ}}$ (along with read data) during Read operations. Indicate if the associated read data byte is inverted (QINVx = 1) or not (QINVx = 0). QINV0 - associated with Q[8:0] in x18 and x36. QINV1 - associated with Q[17:9] in x18 and x36. QINV2 - associated with Q[26:18] in x36 only. QINV3 - associated with Q[35:27] in x36 only. Note: Treated as NU outputs when Data Inversion is disabled.	Output
QVLD[1:0]	Read Data Valid — Driven high one half cycle before valid read data.	Output
CK, $\overline{\text{CK}}$	Primary Input Clocks — Dual single-ended. Used for latching address and control inputs, for internal timing control, and for output timing control.	Input
$\overline{\text{KD}}[1:0]$, KD[1:0]	Write Data Input Clocks — Dual single-ended. Used for latching write data inputs. KD0, $\overline{\text{KD}}0$: latch D[17:0], DINV[1:0] in x36, and D[8:0], DINV0 in x18. KD1, $\overline{\text{KD}}1$: latch D[35:18], DINV[3:2] in x36, and D[17:9], DINV1 in x18.	Input
$\overline{\text{CQ}}[1:0]$, CQ[1:0]	Read Data Output Clocks — Free-running output (echo) clocks, tightly aligned with read data outputs. Facilitate source-synchronous operation. CQ0, $\overline{\text{CQ}}0$: align with Q[17:0], QINV[1:0] in x36, and Q[8:0], QINV0 in x18. CQ1, $\overline{\text{CQ}}1$: align with Q[35:18], QINV[3:2] in x36, and Q[17:9], QINV1 in x18.	Output
$\overline{\text{R}}$	Read Enable — Registered on $\uparrow\text{CK}$. See the Clock Truth Table for functionality.	Input
$\overline{\text{W}}$	Write Enable — Registered on $\uparrow\text{CK}$. See the Clock Truth Table for functionality.	Input
MRW	Mode Register Write — Registered on $\uparrow\text{CK}$. Can be used synchronously or asynchronously to enable Register Write Mode. See the State and Clock Truth Tables for functionality.	Input
PLL	PLL Enable — Weakly pulled High internally. PLL = 0: disables internal PLL. PLL = 1: enables internal PLL.	Input
RST	Reset — Holds the device inactive and resets the device to its initial power-on state when asserted High. Weakly pulled Low internally.	Input

Symbol	Description	Type
ZQ	Driver / ODT Impedance Control Resistor Input — Must be connected to V_{SS} through an external resistor RQ to program driver and ODT impedances.	Input
RCS	Current Source Resistor Input — Must be connected to V_{SS} through an external 2K Ω resistor to provide an accurate current source for the PLL.	Input
MZT	ODT Mode Select — Sets the default ODT state globally for all input groups during power-up and reset. Must be tied High or Low. MZT = 0: disables ODT on all input groups, regardless of PZT[1:0]. MZT = 1: enables ODT on select input groups, as specified by PZT[1:0]. Note: The ODT state for each input group can be changed at any time via the Configuration Registers.	Input
PZT[1:0]	ODT Configuration Select — Set the default ODT state for various combinations of input groups during power-up and reset, when MZT = 1. Must be tied High or Low. PZT[1:0] = 00: enables ODT on write data only. PZT[1:0] = 01: enables ODT on write data and input clocks. PZT[1:0] = 10: enables ODT on write data, address, and control. PZT[1:0] = 11: enables ODT on write data, input clocks, address, and control. Note: The ODT state for each input group can be changed at any time via the Configuration Registers.	Input
V_{DD}	Core Power Supply	—
V_{DDQ}	I/O Power Supply	—
V_{REF}	Input Reference Voltage — Input buffer reference voltage.	—
V_{SS}	Ground	—
TCK	JTAG Clock — Weakly pulled Low internally.	Input
TMS	JTAG Mode Select — Weakly pulled High internally.	Input
TDI	JTAG Data Input — Weakly pulled High internally.	Input
TDO	JTAG Data Output	Output
MCH	Must Connect High — May be tied to V_{DDQ} directly or via a 1k Ω resistor.	Input
MCL	Must Connect Low — May be tied to V_{SS} directly or via a 1k Ω resistor.	Input
NC	No Connect — There is no internal chip connection to these pins. They may be left unconnected, or tied/driven High or Low.	—
NU _I	Not Used Input — There is an internal chip connection to these input pins, but they are unused by the device. They are pulled High internally. They may be left unconnected or tied/driven High. They should not be tied/driven Low.	Input
NU _O	Not Used Output — There is an internal chip connection to these output pins, but they are unused by the device. The drivers are tri-stated internally. They should be left unconnected.	Output

Initialization Summary

Prior to functional use, these devices must first be initialized and configured. The steps described below will ensure that the internal logic has been properly reset, and that functional timing parameters have been configured.

Flow Chart

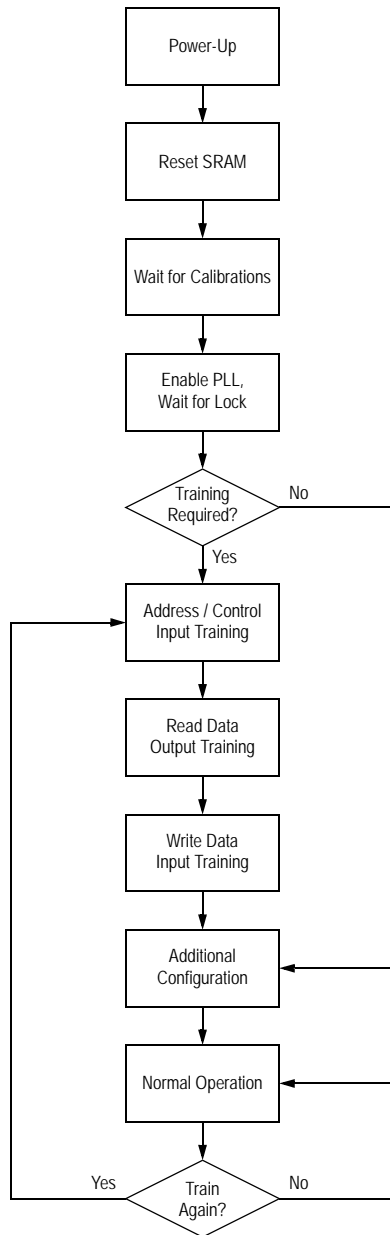

Notes:

1. MZT and PZT[1:0] mode pins are used to set the default ODT state of all input groups at power-up, and whenever RST is asserted High. The ODT state for each input group can be changed any time thereafter using Register Write Mode to program certain bits in the Configuration Registers.
2. Calibrations are performed for driver impedance, ODT impedance, and the PLL current source immediately after RST is de-asserted Low. The calibrations can take up to 384K cycles total. See the Power-Up and Reset Requirements section for more information.
3. The PLL can be enabled by the PLL pin, or by the PLL Enable (PLE) bit in the Configuration Registers. See the PLL Operation section for more information.
4. If the PLE register bit is used to enable the PLL, then Register Write Mode will likely have to be utilized in the "Asynchronous, Pre-Input Training" method in order to change the state of the bit, since Address / Control Input Training has not yet been performed. See the Configuration Registers section for more information.
5. It can take up to 64K cycles for the PLL to lock after it has been enabled.
6. Special Loopback Modes are available in these devices to perform Address / Control Input Training; they are selected and enabled via the Loopback Mode Select (LBK[1:0]) and Loopback Mode Enable (LBKE) bits in the Configuration Registers.
7. If Loopback Modes are used to perform Address / Control Input Training, then Register Write Mode will likely have to be utilized in the "Asynchronous, Pre-Input Training" method in order to change the states of the LBK[1:0] and LBKE register bits.
8. Loopback Modes can also be used for Read Data Output Training, if desired. See the Signal Timing Training and Loopback Mode sections for more information.
9. "Additional Configuration" includes any other configuration changes required by the system. Since this step is performed after Address / Control Input Training, Register Write Mode can be utilized in the "Asynchronous, Post-Input Training" method (or perhaps the "Synchronous" method, if the synchronous timing requirements can be met at the particular operating frequency).
10. It is up to the system to determine if/when re-training is necessary.

Power-Up and Reset Requirements

For reliability purposes, power supplies must power up simultaneously, or in the following sequence:

V_{SS} , V_{DD} , V_{DDQ} , V_{REF} and inputs.

Power supplies must power down simultaneously, or in the reverse sequence.

After power supplies power up, the following start-up sequence must be followed.

Step 1: Assert RST High for at least 1ms.

While RST is asserted high:

- The PLL is disabled.
- The states of \overline{R} , \overline{W} , and MRW control inputs are ignored.

Note: If possible, RST should be asserted High before input clocks begin toggling, and remain asserted High until input clocks are stable and toggling within specification, in order to prevent unstable, out-of-spec input clocks from causing trouble in the SRAM.

Step 2: Begin toggling input clocks.

After input clocks begin toggling, but not necessarily within specification:

- Q are placed in the non-Read state, and remain so until the first Read operation.
- QVLD are driven Low, and remain so until the first Read operation.
- CQ, \overline{CQ} begin toggling, but not necessarily within specification.

Step 3: Wait until input clocks are stable and toggling within specification.

Step 4: De-assert RST Low.

Step 5: Wait at least 384K (393,216) cycles.

During this time:

- Driver and ODT impedances are calibrated. Can take up to 320K cycles.
- The current source for the PLL is calibrated (based on RCS pin). Can take up to 64K cycles.

Step 6: Enable the PLL.

Step 7: Wait at least 64K (65,536) cycles for the PLL to lock.

After the PLL has locked:

- CQ, \overline{CQ} begin toggling within specification.

Step 8: Continue initialization (see the Initialization Flow Chart).

Reset Usage

Although not generally recommended, RST may be asserted High at any time after completion of the initial power-up sequence described above, to reset the SRAM control logic to its initial power-on state. However, whenever RST is subsequently de-asserted Low, as in step 4 above, steps 5~7 above must be followed before normal operation is resumed. It is up to the system to determine whether further re-initialization beyond step 7 (as outlined in the Initialization Flow Chart) is required before normal operation is resumed.

Note: Memory array content may be perturbed/corrupted when RST is asserted High.

PLL Operation

A PLL is implemented in these devices to control all output timing. It uses the CK input clock as a source, and is enabled when all of the following conditions are met:

1. RST is de-asserted Low, and
2. Either the PLL Enable pin (PLL) or the PLL Enable register bit (PLE) is asserted High, and
3. CK cycle time $\leq t_{\text{CKHKH}}$ (max), as specified in the AC Timing Specifications section.

Once enabled, the PLL requires 64K stable clock cycles in order to lock/synchronize properly.

When the PLL is enabled, it aligns output clocks and read data to input clocks (with some fixed delay), and it generates all mid-cycle output timing. See the Output Timing section for more information.

The PLL can tolerate changes in input clock frequency due to clock jitter (i.e. such jitter will not cause the PLL to lose lock/synchronization), provided the cycle-to-cycle jitter does not exceed 200ps (see “ t_{KJITcc} ” in the AC Timing Specifications section for more information). However, the PLL must be resynchronized (i.e. disabled and then re-enabled) whenever the nominal input clock frequency is changed.

The PLL is disabled when any of the following conditions are met:

1. RST is asserted High, or
2. Both the PLL Enable pin (PLL) and the PLL Enable register bit (PLE) are deasserted Low, or
3. CK is stopped for at least 30ns, or CK cycle time $\geq 30\text{ns}$.

On-Chip Error Correction

These devices implement a single-error correct, single-error detect (SEC-SED) ECC algorithm (specifically, a Hamming Code) on each 18-bit data word transmitted in DDR fashion on each 9-bit data bus (i.e., transmitted on D/Q[8:0], D/Q[17:9], D/Q[26:18], and D/Q[35:27]). To accomplish this, 5 ECC parity bits (invisible to the user) are utilized per every 18 data bits (visible to the user). As such, these devices actually comprise 184Mb of memory, of which 144Mb are visible to the user.

The ECC algorithm cannot detect multi-bit errors. However, these devices are architected in such a way that a single SER event very rarely causes a multi-bit error across any given “transmitted data unit”, where a “transmitted data unit” represents the data transmitted as the result of a single read or write operation to a particular address. The extreme rarity of multi-bit errors results in the SER mentioned previously (i.e., <0.002 FITs/Mb, measured at sea level).

Not only does the on-chip ECC significantly improve SER performance, but it can also free up the entire memory array for data storage. Very often SRAM applications allocate 1/9th of the memory array (i.e., one “error bit” per eight “data bits”, in any 9-bit “data byte”) for error detection (either simple parity error detection, or system-level ECC error detection and correction). Depending on the application, such error-bit allocation may be unnecessary in these devices, in which case the entire memory array can be utilized for data storage, effectively providing 12.5% greater storage capacity compared to SRAMs of the same density not equipped with on-chip ECC.

Configuration Registers

These devices utilize a set of registers for device configuration. The configuration registers are written via **Register Write Mode**, which is initiated by asserting MRW High and \bar{R} Low. When Register Write Mode is utilized, up to sixteen distinct 6-bit registers can be programmed using SDR timing on the SA[10:1] address input pins. The D data input pins are not used.

Note: Register Write Mode only provides the ability to write the configuration registers. The ability to read the configuration registers is provided via a private JTAG instruction and register. Please contact GSI for more information.

Register Write Mode can be utilized in two ways:

1. **Asynchronous Method:** MRW is driven asynchronously, such that it does not meet setup and hold time specs to \uparrow CK.
2. **Synchronous Method:** MRW is driven synchronously, such that it meets setup and hold time specs to \uparrow CK.

Regardless how Register Write Mode is utilized, at least 16 NOPs must be initiated before beginning a Register Write sequence, to ensure any previous Read and Write operations are completed before the sequence begins. And, at least 16 NOPs must be initiated after completing a Register Write sequence and before initiating Read and Write operations, and before utilizing Loopback Mode, to allow sufficient time for the newly programmed register settings to take effect.

Register Write Mode Utilization - Asynchronous Method

Register Write Mode can be utilized asynchronously up to the full operating speed of the device. When Register Write Mode is utilized asynchronously, there are two cases to consider:

1. **Pre Input Training:** SA[10:1], \bar{R} , \bar{W} are driven such that they do not meet setup and hold time specs to \uparrow CK.
2. **Post Input Training:** SA[10:1], \bar{R} , \bar{W} are driven such that they meet setup and hold time specs to \uparrow CK.

Each case is examined separately below.

Pre Input Training Requirements

In this case, MRW, \bar{R} , \bar{W} , and SA[10:1] are all driven asynchronously. When Register Write Mode is utilized in this manner, only one register can be programmed during any particular instance that MRW is asserted High.

The requirements for this usage case are as follows:

- At least 16 NOPs must be initiated before and after the Register Write sequence.
- MRW High must meet minimum pulse width requirements (tMRWPW).
- \bar{R} Low and SA[10:1] Valid must meet minimum setup time requirements (tMRWS) to MRW High.
- \bar{R} Low and SA[10:1] Valid must meet minimum hold time requirements (tMRWH) from MRW Low.
- \bar{W} High must also meet minimum setup time requirements (tMRWS) to MRW High, if inadvertent memory writes are to be prevented during the Register Write process. Otherwise, \bar{W} state is “don’t care”.
- \bar{W} High must also meet minimum hold time requirements (tMRWH) from MRW Low, if inadvertent memory writes are to be prevented during the Register Write process. Otherwise, \bar{W} state is “don’t care”.

Note: tMRWPW = tMRWS = tMRWH = 4 cycles (minimum).

Note: Inadvertent memory reads will occur while MRW and \bar{R} are Low during the Register Write process. The memory reads are harmless, and can be ignored.

Post Input Training Requirements

In this case, MRW is driven asynchronously, whereas \bar{R} , \bar{W} , and SA[10:1] are all driven synchronously (i.e. they all meet setup and hold time specs to $\uparrow\text{CK}$). When Register Write Mode is utilized in this manner, multiple registers can be programmed during any particular instance that MRW is asserted High. The timing diagrams below arbitrarily show four registers programmed while MRW is asserted High, but in practice it can be any number greater than or equal to one.

The requirements for this usage case are as follows:

- At least 16 NOPs must be initiated before and after the Register Write(s).
- MRW High must meet minimum setup time requirements (t_{MRWS}) to the $\uparrow\text{CK}$ that generates the first Register Write.
- MRW High must meet minimum hold time requirements (t_{MRWH}) from the $\uparrow\text{CK}$ that generates the first NOP after the last Register Write.
- \bar{R} must be driven Low (synchronously) and SA[10:1] must be driven Valid (synchronously) for each Register Write.
- \bar{W} state is a “don’t care” (synchronously) for each Register Write.

Note: $t_{\text{MRWS}} = t_{\text{MRWH}} = 4$ cycles (minimum).

Asynchronous Register Write Timing Diagram - Pre Input Training

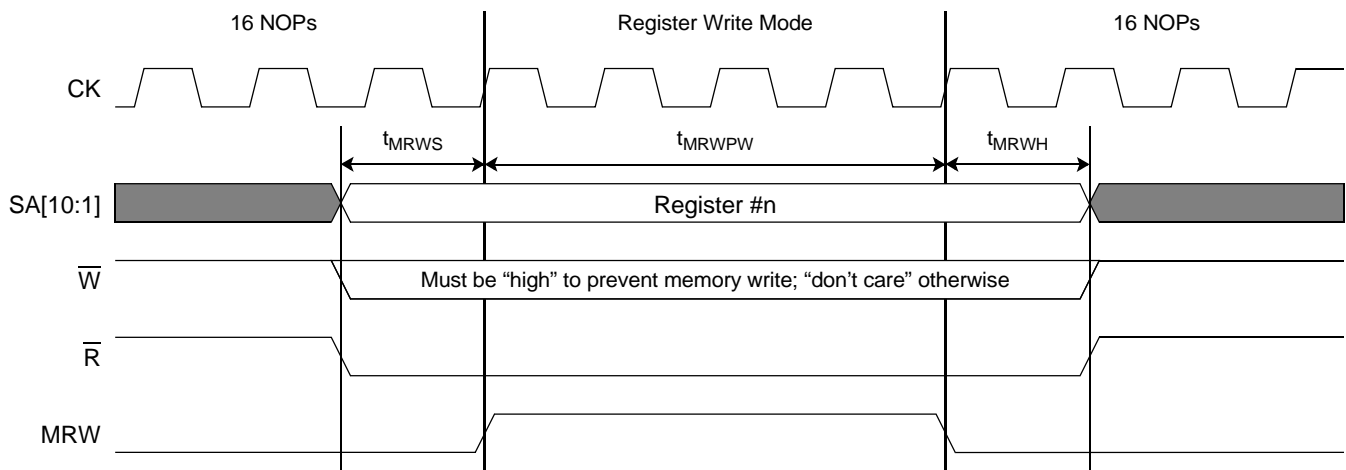

Asynchronous Register Write Timing Diagram - Post Input Training

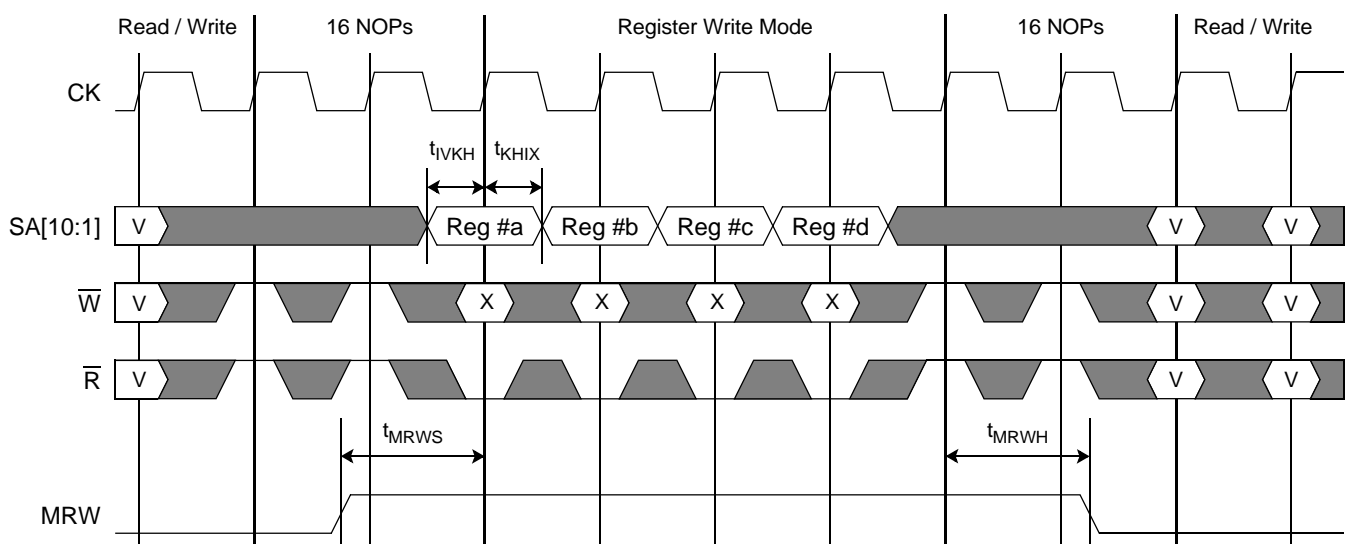

Register Write Mode Utilization - Synchronous Method

Register Write Mode can also be utilized synchronously up to the full operating speed of the device. However, MRW cannot be trained using Loopback Mode, so the ability to use it synchronously may be limited to slower operating frequencies where the lack of training capability is less problematic for the user.

In this case, MRW, \bar{R} , \bar{W} , and SA[10:1] are all driven synchronously (i.e. they all meet setup and hold time specs to $\uparrow\text{CK}$). When Register Write Mode is utilized in this manner, multiple registers can be programmed in successive cycles. The timing diagrams below arbitrarily show four registers programmed in successive cycles, but in practice it can be any number greater than or equal to one.

The requirements for this usage case are as follows:

- At least 16 NOPs must be initiated before and after the Register Write(s).
- MRW must be driven High (synchronously), \bar{R} must be driven Low (synchronously), and SA[10:1] must be driven Valid (synchronously) for each Register Write.
- \bar{W} state is a “don’t care” (synchronously) for each Register Write.

Synchronous Register Write Timing Diagram

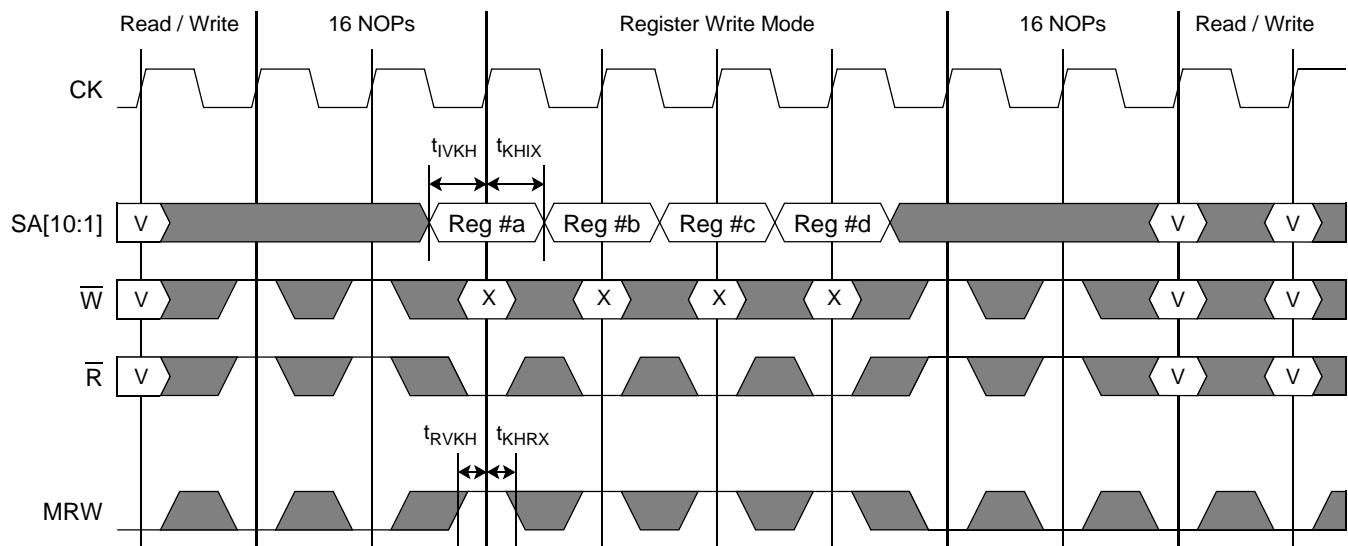

Register Description

As described previously, Register Write Mode provides the ability to program up to sixteen distinct 6-bit configuration registers using SDR timing on the SA[10:1] address input pins. Specifically, SA[4:1] are used to select one of the sixteen distinct registers, and SA[10:5] are used to program the six data bits of the selected register.

The registers are defined as follows:

Address	SA10	SA9	SA8	SA7	SA6	SA5	SA4	SA3	SA2	SA1	Reg #
Pin	8G	6G	8J	6J	8M	6M	8P	6P	8T	6T	
Bit Usage	Register Data Bits						Register Select Bits				
Active		DI				RLM	0	0	0	0	0
Active			RSVD[2:0]			PLE	0	0	0	1	1
Active				LBK[1:0]		LBKE	0	0	1	0	2
Active		DZT		KDZT		CKZT	0	0	1	1	3
Active				CZT		AZT	0	1	0	0	4
Unused							All Others except "111X"				5 ~ 13
Active	Reserved for GSI Internal Use Only						1	1	1	X	14 ~ 15

Notes:

- Unused/unlabeled register bits should be written to "0".
- The RSVD[2:0] bits in Register #1 should be written to "100".
- Registers #14 and #15 are reserved for GSI internal use only. Users should not access these registers.

Register Bit Definitions

Read Latency Select	
RLM	
0	reserved
1	Read Latency = 6 cycles
1	POR/RST Default

PLL Enable	
PLE	
0	Disable PLL, if PLL pin = 0
1	Enable PLL
0	POR/RST Default

Data Inversion Enable	
DI	
0	Disable Data Inversion
1	Enable Data Inversion
0	POR/RST Default

Loopback Mode Enable	
LBKE	
0	Disable Loopback Mode
1	Enable Loopback Mode
0	POR/RST Default

Loopback Mode Select		
LBK[1:0]		
0	0	XOR Loopback Mode, input group #1
0	1	XOR Loopback Mode, input group #2
1	0	INV Loopback Mode, input group #1
1	1	INV Loopback Mode, input group #2
0	0	POR/RST Default

Note: In the ODT Control register bit definitions below, MZT and PZT[1:0] pins set the default state of the register bits at power-up and whenever RST is asserted High. The register bits can then be overwritten (via Register Write Mode), while RST is de-asserted Low, to change the state of the feature controlled by the register bits.

Input Clock ODT Control	
CKZT	
KDZT	
0	disabled
1	enabled: $PU = 0.3 \cdot RQ$
0, if MZT = 0 or PZT0 = 0 1, if MZT = 1 and PZT0 = 1	POR/RST Default

Address & Control ODT Control	
AZT	
CZT	
0	disabled
1	enabled: $PU = 0.3 \cdot RQ$
0, if MZT = 0 or PZT1 = 0 1, if MZT = 1 and PZT1 = 1	POR/RST Default

Write Data ODT Control	
DZT	
0	disabled
1	enabled: $PU = 0.3 \cdot RQ$
0, if MZT = 0 1, if MZT = 1	POR/RST Default

Signal Timing Training

Signal timing training (aka “deskew”) is often required for reliable signal transmission between components at the I/O speeds supported by these devices. Typically, the timing training is performed in the following sequence:

Step 1: Address / Control input training.

These devices support a special Loopback Mode of operation to facilitate address / control input training.

Step 2: Read Data output training.

These devices support a special Loopback Mode of operation to facilitate read data output training.

Alternatively, slow-frequency Memory Write operations can be used to store DDR data patterns in the memory array reliably (full-frequency Memory Write operations cannot be used because write data signals have not been trained yet), and full-frequency Memory Read operations can then be used to train the read data output signals.

Step 3: Write Data input training.

Since address, control, and read data signals have already been trained at this point, full-frequency Memory Write and Read operations can then be used to train the write data inputs.

Loopback Mode

These devices support two distinct **Loopback Modes** of operation, which can be used to:

1. Perform per-pin training on the address (SA), control (\overline{R} , \overline{W}), and write data clock (KD , \overline{KD}) inputs.
2. Perform per-pin training on the data (Q , $QINV$) outputs.

In both cases, SA , \overline{R} , \overline{W} , KD , \overline{KD} input pin values are sampled, logically manipulated, and looped back to Q , $QINV$ output pins.

Register bit $LBKE$ is used to enable/disable Loopback Mode. When $LBKE = 1$ and $MRW = 0$, Loopback Mode is enabled, and Memory Read and Write operations are blocked regardless of the states of \overline{R} and \overline{W} . When $LBKE = 0$ or $MRW = 1$, Loopback Mode is disabled. See the State Truth Table for more information.

Register bits $LBK[1:0]$ are used to select between the two distinct Loopback Modes supported by the design (controlled by $LBK1$), and between the two groups of inputs used during the selected Loopback Mode (controlled by $LBK0$), as follows:

- $LBK[1:0] = 00$: selects XOR LBK Mode using Input Group 1. Loopback Mode “00”.
- $LBK[1:0] = 01$: selects XOR LBK Mode using Input Group 2. Loopback Mode “01”.
- $LBK[1:0] = 10$: selects INV LBK Mode using Input Group 1. Loopback Mode “10”.
- $LBK[1:0] = 11$: selects INV LBK Mode using Input Group 2. Loopback Mode “11”.

Note: For convenience, KD clocks have been included in the group of inputs that can be trained via Loopback Mode. However, the timing requirement for KD clocks is that their edges be tightly aligned to CK clock edges, unlike the timing requirement for address/control signals, whose edges must be centered (approximately) between CK edges in order to optimize setup and hold times to those CK edges. Consequently, it is questionable whether Loopback Mode can be used to train KD clocks effectively.

Note: When Loopback Mode is enabled, Data Inversion is disabled regardless of the state of register bit DI .

Loopback Latency

Loopback Latency (“ $LBKL$ ”) - i.e. the number of cycles from when the inputs are sampled to when the proper result appears on the output pins, is equal to 7 cycles.

Enabling Loopback Mode

Loopback Mode is enabled as follows:

Step 1: Initiate a Register Write operation with $SA[10:1] = “000ab1.0010”$ to select Register #2, set $LBKE = 1$ to enable Loopback Mode, and set $LBK[1:0]$ to “ab” to select Loopback Mode “ab”.

Step 2: Wait 16 cycles for new register settings to take effect.

Loopback Mode “ab” is enabled after step 2 because $MRW = 0$, $LBKE = 1$, and $LBK[1:0] = “ab”$.

Changing Loopback Modes

Once enabled, Loopback Mode can be changed as follows

Step 1: Initiate a Register Write operation with SA[10:1] = “000cd1.0010” to select Register #2, keep LBKE = 1 to keep Loopback Mode enabled, and set LBK[1:0] to “cd” to select Loopback Mode “cd”.

Step 2: Wait 16 cycles for new register settings to take effect.

Loopback Mode “cd” is enabled after step 2 because MRW = 0, LBKE = 1, and LBK[1:0] = “cd”.

Disabling Loopback Mode

Loopback Mode is disabled as follows:

Step 1: Initiate a Register Write operation with SA[10:1] = “000xx0.0010” to select Register #2 and set LBKE = 0 to disable Loopback Mode.

Step 2: Wait 16 cycles for new register settings to take effect.

Loopback Mode is disabled after step 2 because LBKE = 0.

XOR LBK Mode

XOR LBK Mode is for *address/control input training*. It is defined as follows:

- Each input pin of the selected input group is sampled on $\uparrow\text{CK}$ and $\uparrow\overline{\text{CK}}$.
- For each input sampled, the value sampled on $\uparrow\text{CK}$ is XORed with the value sampled on $\uparrow\overline{\text{CK}}$.
- For each input sampled, the XOR result is subsequently driven out on its associated output pin (concurrently with $\uparrow\text{CQ}$) for one full clock cycle, beginning “LBKL” cycles after the input is sampled.

Consequently, the output data pattern is always SDR regardless of the input data pattern, and regardless whether the SRAM samples the inputs correctly or not. The SDR output data pattern enables address/control inputs to be trained before data outputs.

XOR LBK Mode enables the controller to input various SDR and DDR data patterns on a particular input, and then determine whether the SRAM sampled them correctly or not by observing SDR data patterns on the associated output. Via multiple iterations of this process, the controller can adjust its output timing (in order to adjust the SRAM input timing) until optimum setup and hold margin at both SRAM input sample points is achieved, thereby individually “training” each address/control input pin.

INV LBK Mode

INV LBK Mode is primarily for *read data output training*. It is defined as follows:

- Each input pin of the selected input group is sampled on $\uparrow\text{CK}$ and $\uparrow\overline{\text{CK}}$.
- For each input sampled, the value sampled on $\uparrow\text{CK}$ is subsequently driven out on its associated output pin (concurrently with $\uparrow\text{CQ}$) for half a clock cycle, beginning “LBKL” cycles after the input is sampled.
- For each input sampled, the value sampled on $\uparrow\overline{\text{CK}}$ is *inverted* and then subsequently driven out on its associated output pin (concurrently with $\uparrow\overline{\text{CQ}}$) for half a clock cycle, beginning “LBKL + 0.5” cycles after the input is sampled.

Consequently, the output data pattern is DDR if the input data pattern is SDR (and vice versa), provided the SRAM samples the inputs correctly. Therefore, to ensure deterministic output behavior, address/control inputs should be trained before data outputs.

INV LBK Mode enables the controller to input various SDR (or DDR) data patterns on a particular input, to generate deterministic DDR (or SDR) data patterns on a particular output. The controller latches the output as it would during a normal Read operation, and verifies whether it received the expected values or not. Via multiple iterations of this process, the controller can adjust its input timing until optimum setup and hold margin at both controller input sample points is achieved, thereby individually “training” each read data output pin.

Note: INV LBK Mode can be used for address/control input training, if desired. However, such usage can be problematic because the output data pattern may be erroneous (i.e. it could be SDR or DDR regardless of the input pattern) if the SRAM samples the input incorrectly. In which case the controller may have difficulty detecting the erroneous behavior, and/or interpreting it.

Entering XOR LBK Mode

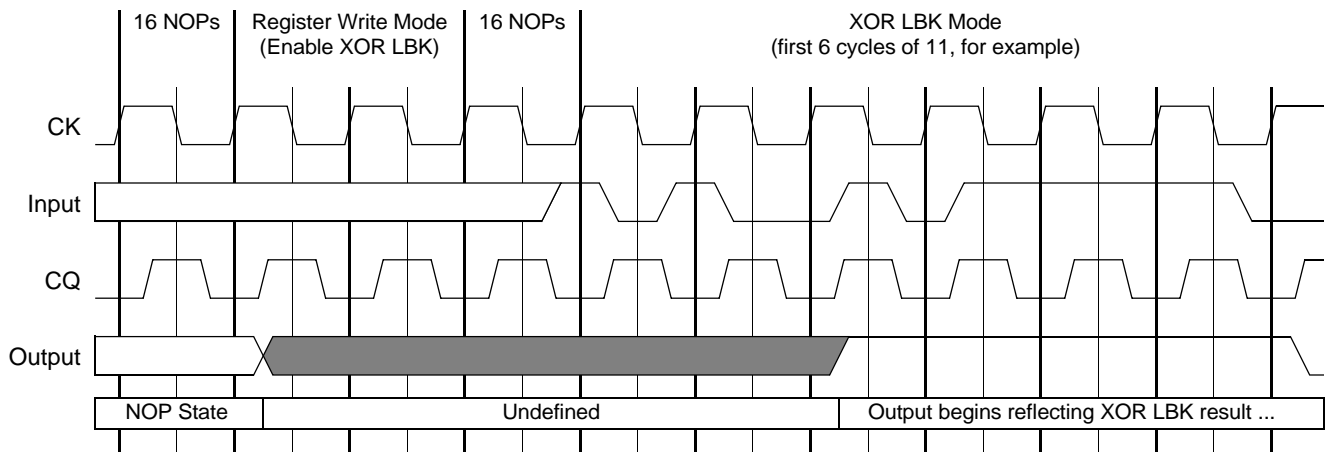

Exiting XOR LBK Mode

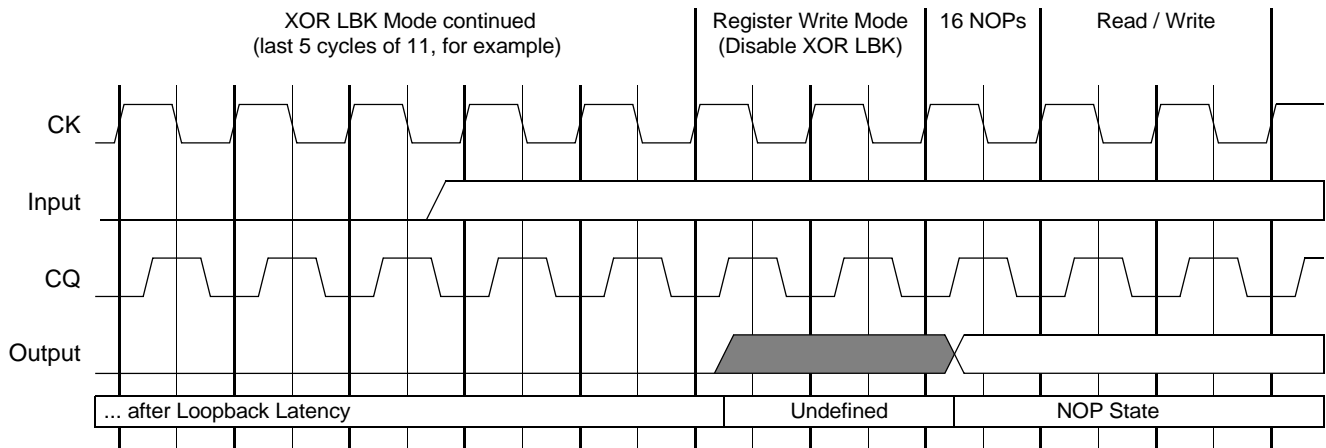

Note: “Input” represents any loop-backed input pin. “Output” represents the output pin on which “Input” is looped back.

Entering INV LBK Mode

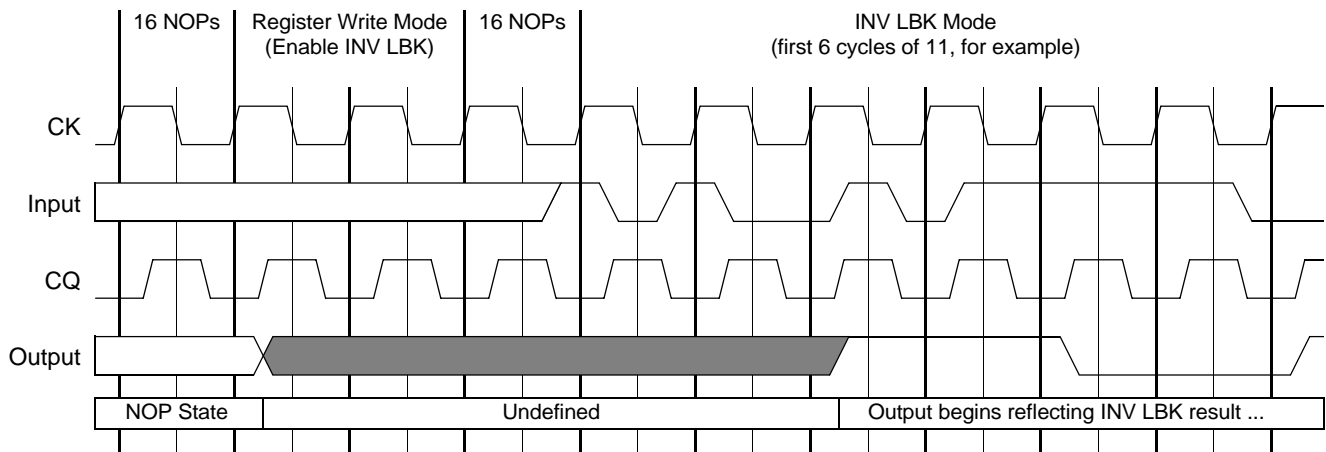

Exiting INV LBK Mode

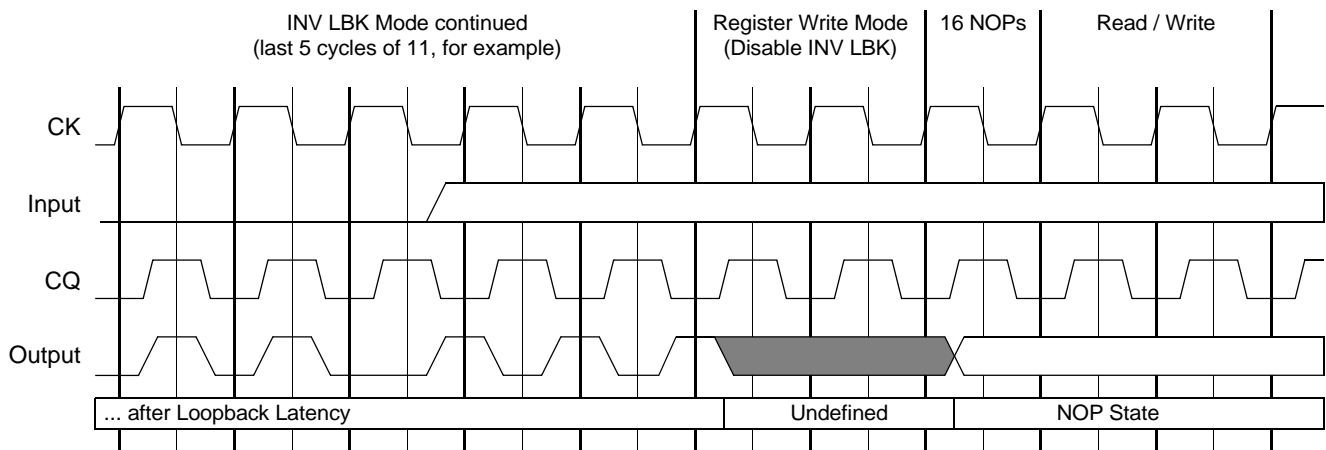

Note: “Input” represents any loop-backed input pin. “Output” represents the output pin on which “Input” is looped back.

Loopback Mode Input Group Definition and Input-to-Output Pin Mapping

Inputs are divided into 2 groups because there are up to 28 inputs to train (22 address, 2 control, and 4 KD clocks), but as few as 18 outputs available to loop them back to (in x18 devices).

There are 20 inputs per group - one per Q, QINV output in x18 devices, and one per two Q, QINV outputs in x36 devices.

Bit #	Input Pins		Input Signals		Output Pins		Output Signals		
	GP1	GP2	GP1	GP2	x18	x36	x18	x36	
1	8T	---	SA2	RSVD	n/a	12Y	n/a	QINV1	Right Side Output Data Byte(s)
2	8P	8V	SA4	NU	13V	13V, 12W	Q8	Q8, Q17	
3	8M	8T	SA6	SA2	13T	13T, 12U	Q7	Q7, Q16	
4	8J	---	SA8	RSVD	13P	13P, 12R	Q6	Q6, Q15	
5	9H	9L	SA16	$\overline{KD0}$	13N	13N, 12P	Q5	Q5, Q14	
6	8G	9K	SA10	KD0	12J	12J, 12M	Q4	Q4, Q13	
7	9F	7H	SA18	\overline{W}	12G	12G, 13H	Q3	Q3, Q12	
8	8E	---	SA12	RSVD	12F	12F, 13G	Q2	Q2, Q11	
9	9D	---	SA20	RSVD	12D	12D, 13E	Q1	Q1, Q10	
10	8C	---	SA14	RSVD	12B	12B, 13C	Q0	Q0, Q9	
20	6C	---	SA13	RSVD	12A	12A	QINV0	QINV0	
1	8T	---	SA2	RSVD	2Y	2Y	QINV1	QINV2	Left Side Output Data Byte(s)
11	6T	---	SA1	RSVD	2W	2W, 1V	Q9	Q18, Q27	
12	6P	6V	SA3	SA21	2U	2U, 1T	Q10	Q19, Q28	
13	6M	---	SA5	RSVD	2R	2R, 1P	Q11	Q20, Q29	
14	6J	7N	SA7	\overline{R}	2P	2P, 1N	Q12	Q21, Q30	
15	5H	5L	SA15	$\overline{KD1}$	2M	2M, 2J	Q13	Q22, Q31	
16	6G	5K	SA9	KD1	1H	1H, 2G	Q14	Q23, Q32	
17	5F	---	SA17	RSVD	1G	1G, 2F	Q15	Q24, Q33	
18	6E	---	SA11	RSVD	1E	1E, 2D	Q16	Q25, Q34	
19	5D	6C	SA19	SA13	1C	1C, 2B	Q17	Q26, Q35	
20	6C	---	SA13	RSVD	n/a	2A	n/a	QINV3	

Notes:

- Blue shading indicates input pins that are unused (NU) in certain device configurations. During Loopback Mode, the associated output pins loop back the states of those input pins regardless whether they are used or unused.
- Gray shading indicates Group 2 inputs that are reserved (RSVD) for future use. During Loopback Mode, the associated output pins act as if they were looping back input pins tied Low.
- Green shading indicates QINV output pins that are unused (NU) when Data Inversion is disabled. During Loopback Mode, they loop back the states of the associated input pins regardless whether Data Inversion is enabled or disabled.
- The 18 unused Q and the 2 unused QINV in x18 devices remain in their "NU" states during Loopback Mode.
- Bit #1 and bit #20 are repeated in the table to show that they are used in both the right and left side data bytes in x36 devices.

Address Bus Utilization and Bank Access Restrictions

The address bus is a non-multiplexed SDR bus. One memory address may be loaded per cycle - a read address at $\uparrow\text{CK}$ or a write address at $\uparrow\text{CK}$; consequently only one memory operation - a Read or a Write - may be initiated per clock cycle. The address bus is also sampled at $\uparrow\text{CK}$ during a Register Write operation.

Address Bit Encoding

Command	Addr Load	Device	SA Address Bits																							
			21	20	19	18	17	16	15	14	13	12	11	10	9	8	7	6	5	4	3	2	1	0		
Read	$\uparrow\text{CK}$	x36	NU	Address												BA	Address					BA	NU			
		x18	Address												BA	Address					BA	NU				
Write	$\uparrow\text{CK}$	x36	NU	Address												BA	Address					BA	NU			
		x18	Address												BA	Address					BA	NU				
Register Write	$\uparrow\text{CK}$	x36	NU	X	X	X	X	X	X	X	X	X	X	X	X	Register Data					Register #					NU
		x18	X	X	X	X	X	X	X	X	X	X	X	X	X	Register Data					Register #					NU

Note: BA = Bank Address

Bank Access Restrictions

1. In all devices, Read in cycle “n” must be to a different bank than Write in cycle “n-4” (due to Write Buffering).

Note: Bank restriction #1 (the only restriction in SIO-B4 devices) can be avoided by always initiating Reads “in phase” - that is, by always initiating Reads an even number of cycles apart.

Consider a typical sequence of alternating Read and Write operations:

R -> W -> R -> W -> R -> W -> R -> W -> R -> W -> R -> W -> R -> W.

In this case the Reads are always “in phase” because they always occur 2 cycles apart. Consequently, when a Read occurs in cycle “n”, the operation in cycle “n-4” is always a Read, and therefore this bank restriction is automatically avoided.

Now consider the following sequence, where *NOPs* replace Read and Write operations in the typical sequence:

R -> W -> NOP -> W -> R -> NOP -> R -> NOP -> NOP -> W -> R -> W.

In this case the Reads stay “in phase” because they occur 2 or 4 cycles apart. Consequently, when a Read occurs in cycle “n”, the operation in cycle “n-4” is always a Read or NOP, and therefore this bank restriction is automatically avoided.

Now consider the following sequence, where *an even number of NOPs* are inserted into the typical sequence:

R -> W -> NOP -> NOP -> R -> W -> R -> NOP -> NOP -> W -> R -> W -> R -> W -> R -> W.

In this case the Reads stay “in phase” because they occur 2 or 4 cycles apart. Consequently, when a Read occurs in cycle “n”, the operation in cycle “n-4” is always a Read or NOP, and therefore this bank restriction is automatically avoided.

Now consider the following sequence, where *an odd number of NOPs* are inserted into the typical sequence:

R -> W -> NOP -> R -> W -> **R** -> W -> R -> NOP -> W -> **R** -> W -> NOP -> NOP -> NOP -> **R** -> W.

In this case the Reads become “out of phase” because they sometimes occur 3 or 5 cycles apart. Consequently, when a Read occurs in cycle “n”, the operation in cycle “n-4” is sometimes a Write (see the red bolded Reads for examples where this occurs), and therefore this bank restriction must be taken into consideration when the Reads are initiated.

Data Bus Inversion

Because the POD I/O standard employs high-side (pull-up) termination only, signals driven High consume less power than those driven Low. Consequently, these devices provide the ability to invert all data pins on a per byte basis, such that any transmitted data byte always contains more 1s than 0s, thereby reducing average I/O power as well as SSO noise. To accomplish this, one data inversion (DINV, QINV) bit is utilized per 9-bit data (D, Q) byte.

During Write operations, the controller inverts a particular 9-bit write data byte before transmitting it to the SRAM if it contains less than 5 High bits; otherwise, it transmits the data byte uninverted. If it inverts the data byte, the controller drives the corresponding write data inversion bit High; otherwise, it drives it Low. Upon receiving the write data byte, the SRAM uses the state of the corresponding write data inversion bit to determine whether or not to invert the data byte before storing it in the memory array.

During Read operations, the SRAM inverts a particular 9-bit read data byte before transmitting it to the controller if it contains less than 5 High bits; otherwise, it transmits the data byte uninverted. If it inverts the data byte, the SRAM drives the corresponding read data inversion bit High; otherwise, it drives it Low. Upon receiving the read data byte, the controller uses the state of the corresponding read data inversion bit to determine whether or not to invert the data byte before utilizing it.

With this implementation, each 10-bit data group (nine data bits plus one data inversion bit) is guaranteed to have no more than five pins driven low at any given time. Consequently, no more than five pins in each group can switch in the same direction during each bit time, reducing SSO noise effects.

Note: Data Inversion can be enabled and disabled via register bit DI.

Read Latency

Read Latency (i.e. the number of cycles from read command input to first read data output) is specified as follows:

Read Latency	Comment
6 cycles	First read data output 6 cycles after read command input

Note: The RLM register bit must remain “1” in these devices while initiating Read operations, to keep Read Latency = 6 cycles.

Write Latency

Write Latency (i.e. the number of cycles from write command input to first write data input) is specified as follows:

Write Latency	Comment
-1 cycle	First write data input 1 cycle <i>before</i> write command input

Read / Write Coherency

These devices are fully coherent. That is, Read operations always return the most recently written data to a particular address, even when a Read operation to a particular address occurs one cycle after a Write operation to the same address.

State Truth Table

RST	MRW	LBKE	\bar{R}	\bar{W}	SA	D	SRAM State	Q
1	X	X	X	X	X	X	Reset	NOP State
0	1	X	0	X	V	X	Register Write Mode	Undefined
0	0	1	X	X	X	X	Loopback Mode	Loopback
0	1	X	1	See Clock Truth Table			Memory Mode (Read, Write, NOP)	See Clock Truth Table
0	0	0	X					

Note: 1 = High; 0 = Low; V = Valid; X = don't care.

Clock Truth Table

SA	MRW	\bar{R}	\bar{W}	Previous Operation	Current Operation	D, DINV				Q, QINV			
$\uparrow\text{CK}$ (t_n)	$\uparrow\text{CK}$ (t_n)	$\uparrow\text{CK}$ (t_n)	$\uparrow\text{CK}$ (t_n)	(t_{n-1})	(t_n)	$\uparrow\text{KD}$ (t_{n-1})	$\uparrow\bar{\text{KD}}$ ($t_{n-1/2}$)	$\uparrow\text{KD}$ (t_n)	$\uparrow\bar{\text{KD}}$ ($t_{n+1/2}$)	$\uparrow\text{CQ}$ (t_{n+6})	$\uparrow\bar{\text{CQ}}$ ($t_{n+6.5}$)	$\uparrow\text{CQ}$ (t_{n+7})	$\uparrow\bar{\text{CQ}}$ ($t_{n+7.5}$)
X	0	1	1	NOP	NOP	X	X	—		1		—	
X	0	1	X	Write	NOP	D3	D4	—		1		—	
X	0	X	1	Read	NOP	X	X	—		Q3	Q4	—	
V	0	1	0	NOP	Write	D1	D2	D3	D4	1		—	
V	0	X	0	Read	Write	D1	D2	D3	D4	Q3	Q4	—	
V	0	0	X	NOP	Read	X	X	—		Q1	Q2	Q3	Q4
V	0	0	X	Write	Read	D3	D4	—		Q1	Q2	Q3	Q4
V	1	0	X	NOP	Register Write	X	X	—		Undefined		Undefined	
	1	1	X	NOP	NOP	X	X	—		1		—	

Notes:

- 1 = High; 0 = Low; V = Valid; X = don't care.
- D1, D2, D3, and D4 indicate the first, second, third, and fourth pieces of write data transferred during Write operations.
- Q1, Q2, Q3, and Q4 indicate the first, second, third, and fourth pieces of read data transferred during Read operations.
- Q pins are driven High for one cycle in response to NOP and Write commands, RL cycles after the command is sampled, except when preceded by a Read command.

Input Timing

These devices utilize three pairs of positive and negative input clocks, CK & $\overline{\text{CK}}$ and KD[1:0] & $\overline{\text{KD}}$ [1:0], to latch the various synchronous inputs. Specifically:

During Memory Mode, $\uparrow\text{CK}$ latches address (SA) inputs, and $\uparrow\text{CK}$ latches control ($\overline{\text{R}}$, $\overline{\text{W}}$, MRW) inputs.

During Register Write Mode, $\uparrow\text{CK}$ latches address and control inputs.

During Loopback Mode, $\uparrow\text{CK}$ and $\uparrow\overline{\text{CK}}$ latch address, control, and write data clock (KD, $\overline{\text{KD}}$) inputs.

During Memory Mode, $\uparrow\text{KD}$ [1:0] and $\uparrow\overline{\text{KD}}$ [1:0] latch particular write data (D, DINV) inputs, as follows:

- $\uparrow\text{KD0}$ and $\uparrow\overline{\text{KD0}}$ latch D[17:0], DINV[1:0] in x36 devices, and D[8:0], DINV0 in x18 devices.
- $\uparrow\text{KD1}$ and $\uparrow\overline{\text{KD1}}$ latch D[35:18], DINV[3:2] in x36 devices, and D[17:9], DINV1 in x18 devices.

Output Timing

These devices provide two pairs of positive and negative output clocks (aka “echo clocks”), CQ[1:0] & $\overline{\text{CQ}}$ [1:0], whose timing is tightly aligned with read data in order to enable reliable source-synchronous data transmission.

These devices utilize a PLL to control output timing. When the PLL is enabled, it generates 0° and 180° phase clocks from $\uparrow\text{CK}$ that control read data output clock (CQ, $\overline{\text{CQ}}$), read data (Q, QINV), and read data valid (QVLD) output timing, as follows:

- $\uparrow\text{CK}+0^\circ$ generates $\uparrow\text{CQ}$ [1:0], $\downarrow\overline{\text{CQ}}$ [1:0], Q1 active, and Q2 inactive.
- $\uparrow\text{CK}+180^\circ$ generates $\uparrow\overline{\text{CQ}}$ [1:0], $\downarrow\text{CQ}$ [1:0], Q1 inactive, Q2 active, and QVLD active/inactive.

Note: Q1 and Q2 indicate the first and second pieces of read data transferred in any given clock cycle during Read operations.

When the PLL is enabled, $\uparrow\text{CQ}$ is aligned to an internally-delayed version of $\uparrow\text{CK}$. See the AC Timing Specifications for more information.

$\uparrow\text{CQ}$ [1:0] and $\uparrow\overline{\text{CQ}}$ [1:0] align with particular Q, QINV, and QVLD outputs, as follows:

- $\uparrow\text{CQ0}$ and $\uparrow\overline{\text{CQ0}}$ align with Q[17:0], QINV[1:0], QVLD0 in x36 devices, and Q[8:0], QINV0, QVLD0 in x18 devices.
- $\uparrow\text{CQ1}$ and $\uparrow\overline{\text{CQ1}}$ align with Q[35:18], QINV[3:2], QVLD1 in x36 devices, and Q[17:9], QINV1, QVLD1 in x18 devices.

Driver Impedance Control

Programmable Driver Impedance is implemented on the following output signals:

- CQ, $\overline{\text{CQ}}$, Q, QINV, QVLD.

Driver impedance is programmed by connecting an external resistor RQ between the ZQ pin and V_{SS}.

Driver impedance is set to the programmed value within 320K cycles after input clocks are operating within specification and RST is de-asserted Low. It is updated periodically thereafter to compensate for temperature and voltage fluctuations in the system.

Output Signal	Pull-Down Impedance (R _{OUTL})	Pull-Up Impedance (R _{OUTH})
CQ, $\overline{\text{CQ}}$, Q, QINV, QVLD	RQ*0.2 ± 15%	RQ*0.3 ± 15%

Notes:

1. R_{OUTL} and R_{OUTH} apply when 175Ω ≤ RQ ≤ 225Ω.
2. The mismatch between R_{OUTL} and R_{OUTH} is less than 10%, guaranteed by design.

ODT Impedance Control

Programmable ODT Impedance is implemented on the following input signals:

- CK, $\overline{\text{CK}}$, KD, $\overline{\text{KD}}$, SA, $\overline{\text{R}}$, $\overline{\text{W}}$, MRW, D, DINV.

ODT impedance is programmed by connecting an external resistor RQ between the ZQ pin and V_{SS}.

ODT impedance is set to the programmed value within 320K cycles after input clocks are operating within specification and RST is de-asserted Low. It is updated periodically thereafter to compensate for temperature and voltage fluctuations in the system.

Input Signal	Register Bit	Pull-Up Impedance (R _{INH})
CK, $\overline{\text{CK}}$	CKZT = 0	off
	CKZT = 1	RQ*0.3 ± 15%
KD, $\overline{\text{KD}}$	KDZT = 0	off
	KDZT = 1	RQ*0.3 ± 15%
SA	AZT = 0	off
	AZT = 1	RQ*0.3 ± 15%
$\overline{\text{R}}$, $\overline{\text{W}}$, MRW	CZT = 0	off
	CZT = 1	RQ*0.3 ± 15%
D, DINV	DZT = 0	off
	DZT = 1	RQ*0.3 ± 15%

Notes:

1. R_{INH} applies when 175Ω ≤ RQ ≤ 225Ω.
2. All ODT is disabled during JTAG EXTEST and SAMPLE-Z instructions.

Absolute Maximum Ratings

Parameter	Symbol	Rating	Units	Notes
Core Supply Voltage	V_{DD}	-0.3 to +1.4	V	
I/O Supply Voltage	V_{DDQ}	-0.3 to V_{DD}	V	
Input Voltage (HS)	V_{IN1}	-0.3 to $V_{DDQ} + 0.3$	V	2
	V_{IN2}	$V_{DDQ} - 1.5$ to +1.7		
Input Voltage (LS)	V_{IN3}	-0.3 to $V_{DDQ} + 0.3$	V	3
Junction Temperature	T_J	0 to 125	°C	
Storage Temperature	T_{STG}	-55 to 125	°C	

Notes:

- Permanent damage to the device may occur if the Absolute Maximum Ratings are exceeded. Operation should be restricted to Recommended Operating Conditions. Exposure to conditions exceeding the Recommended Operating Conditions for an extended period of time may affect reliability of this component.
- Parameters apply to High Speed Inputs: CK, \overline{CK} , KD, \overline{KD} , SA, D, DINV, \overline{R} , \overline{W} , MRW. V_{IN1} and V_{IN2} must both be met.
- Parameters apply to Low Speed Inputs: RST, PLL, MZT, PZT.

Recommended Operating Conditions

Parameter	Symbol	Min	Typ	Max	Units	Notes
Core Supply Voltage	V_{DD}	1.2	1.25	1.35	V	
I/O Supply Voltage	V_{DDQ}	1.15	1.2	V_{DD}	V	
Commercial Junction Temperature	T_{JC}	0	—	85	°C	
Industrial Junction Temperature	T_{JI}	-40	—	100	°C	

Note: For reliability purposes, power supplies must power up simultaneously, or in the following sequence:

V_{SS} , V_{DD} , V_{DDQ} , V_{REF} , and Inputs.

Power supplies must power down simultaneously, or in the reverse sequence.

Thermal Impedances

Package	θ_{JA} (C°/W) Airflow = 0 m/s	θ_{JA} (C°/W) Airflow = 1 m/s	θ_{JA} (C°/W) Airflow = 2 m/s	θ_{JB} (C°/W)	θ_{JC} (C°/W)
FBGA	13.67	10.28	9.31	3.08	0.13

I/O Capacitance

Parameter	Symbol	Min	Max	Units	Notes
Input Capacitance	C_{IN}	—	5.0	pF	1, 3
Output Capacitance	C_{OUT}	—	5.5	pF	2, 3

Notes:

- $V_{IN} = V_{DDQ}/2$.
- $V_{OUT} = V_{DDQ}/2$.
- $T_A = 25^\circ\text{C}$, $f = 1\text{ MHz}$.

Input Electrical Characteristics

Parameter	Symbol	Min	Typ	Max	Units	Notes
DC Input Reference Voltage	V_{REFdc}	$0.69 * V_{DDQ}$	$0.70 * V_{DDQ}$	$0.71 * V_{DDQ}$	V	—
DC Input High Voltage (HS)	V_{IH1dc}	$V_{REF} + 0.08$	V_{DDQ}	$V_{DDQ} + 0.15$	V	5
DC Input Low Voltage (HS)	V_{IL1dc}	-0.15	$0.40 * V_{DDQ}$	$V_{REF} - 0.08$	V	1, 5
DC Input High Voltage (LS)	V_{IH2dc}	$0.75 * V_{DDQ}$	V_{DDQ}	$V_{DDQ} + 0.15$	V	6
DC Input Low Voltage (LS)	V_{IL2dc}	-0.15	0	$0.25 * V_{DDQ}$	V	6
AC Input Reference Voltage	V_{REFac}	$0.68 * V_{DDQ}$	$0.70 * V_{DDQ}$	$0.72 * V_{DDQ}$	V	2
AC Input High Voltage (HS)	V_{IH1ac}	$V_{REF} + 0.15$	V_{DDQ}	$V_{DDQ} + 0.25$	V	3-5
AC Input Low Voltage (HS)	V_{IL1ac}	-0.25	$0.40 * V_{DDQ}$	$V_{REF} - 0.15$	V	1, 3-5
AC Input High Voltage (LS)	V_{IH2ac}	$V_{DDQ} - 0.2$	V_{DDQ}	$V_{DDQ} + 0.25$	V	3, 6
AC Input Low Voltage (LS)	V_{IL2ac}	-0.25	0	0.2	V	3, 6

Notes:

- "Typ" parameter applies when Controller $R_{OUTL} = 40\Omega$ and SRAM $R_{INH} = 60\Omega$.
- V_{REFac} is equal to V_{REFdc} plus noise.
- V_{IH} max and V_{IL} min apply for pulse widths less than one-quarter of the cycle time.
- Input rise and fall times must be a minimum of 1V/ns, and within 10% of each other.
- Parameters apply to High Speed Inputs: CK, \overline{CK} , KD, \overline{KD} , SA, D, DINV, \overline{R} , \overline{W} , MRW.
- Parameters apply to Low Speed Inputs: RST, PLL, MZT, PZT.

Output Electrical Characteristics

Parameter	Symbol	Min	Typ	Max	Units	Notes
DC Output High Voltage	V_{OHdc}	—	V_{DDQ}	$V_{DDQ} + 0.15$	V	2
DC Output Low Voltage	V_{OLdc}	-0.15	$0.40 * V_{DDQ}$	—	V	1, 2
AC Output High Voltage	V_{OHac}	—	V_{DDQ}	$V_{DDQ} + 0.25$	V	2
AC Output Low Voltage	V_{OLac}	-0.25	$0.40 * V_{DDQ}$	—	V	1, 2

Note:

1. "Typ" parameter applies when SRAM $R_{OUTL} = 40\Omega$ and Controller $R_{INH} = 60\Omega$.
2. Parameters apply to: CQ, \overline{CQ} , Q, QINV, QVLD.

Leakage Currents

Parameter	Symbol	Min	Max	Units	Notes
Input Leakage Current	I_{LI1}	-2	2	μA	1, 2
	I_{LI2}	-20	2	μA	1, 3
	I_{LI3}	-2	20	μA	1, 4
Output Leakage Current	I_{LO}	-2	2	μA	5, 6

Notes:

1. $V_{IN} = V_{SS}$ to V_{DDQ} .
2. Parameters apply to CK, \overline{CK} , KD, \overline{KD} , SA, D, DINV, \overline{R} , \overline{W} , MRW when ODT is disabled.
Parameters apply to MZT, PZT.
3. Parameters apply to PLL, TMS, TDI (weakly pulled up).
4. Parameters apply to RST, TCK (weakly pulled down).
5. $V_{OUT} = V_{SS}$ to V_{DDQ} .
6. Parameters apply to CQ, \overline{CQ} , Q, QINV, QVLD, TDO.

Operating Currents

Parameter	Symbol	V _{DD} (nom)	1066 MHz	1200 MHz	1333 MHz	Units
x18 Operating Current	I _{DD}	1.25V	2300	2500	2700	mA
x36 Operating Current	I _{DD}	1.25V	3000	3200	3400	mA

Notes:

1. I_{OUT} = 0 mA; V_{IN} = V_{IH} or V_{IL}.
2. Applies at 100% alternating Reads and Writes.

AC Test Conditions

Parameter	Symbol	Conditions	Units
Core Supply Voltage	V _{DD}	1.2 to 1.35	V
I/O Supply Voltage	V _{DDQ}	1.15 to 1.25	V
Input Reference Voltage	V _{REF}	0.84	V
Input High Level	V _{IH}	1.14	V
Input Low Level	V _{IL}	0.54	V
Input Rise and Fall Time	—	2.0	V/ns
Input and Output Reference Level	—	0.84	V

Note: Output Load Conditions R_Q = 200Ω. Refer to figure below.

AC Test Output Load

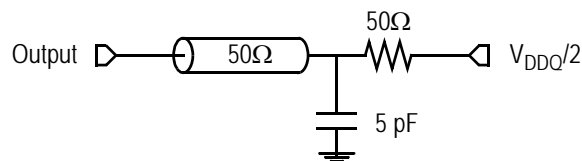

AC Timing Specifications (independent of device speed grade)

Parameter	Symbol	Min	Max	Units	Notes
Input Clock Timing					
Clk High Pulse Width	t_{KHKL}	0.45	—	cycles	1
Clk Low Pulse Width	t_{KLKH}	0.45	—	cycles	1
Clk High to $\overline{\text{Clk}}$ High	$t_{KH\overline{KH}}$	0.45	0.55	cycles	2
Clk High to Write Data Clk High	t_{KHKDH}	-200	+200	ps	3
Clk Cycle-to-Cycle Jitter	t_{KJITcc}	—	60	ps	1,4,5
PLL Lock Time	t_{Klock}	65,536	—	cycles	6
Clk Static to PLL Reset	t_{Kreset}	30	—	ns	7,14
Output Timing					
Clk High to Output Valid / Hold	$t_{KHQV/X}$	+0.4	+1.2	ns	8
		+0.8	+1.6	ns	9
Clk High to Echo Clock High	t_{KHCQH}	+0.4	+1.2	ns	10
		+0.8	+1.6	ns	11
Echo Clk High to Output Valid / Hold	$t_{CQHQV/X}$	-75	+75	ps	12,14
Echo Clk High to $\overline{\text{Echo Clock}}$ High	$t_{CQH\overline{CQH}}$	$0.5 \cdot t_{KHKH} (\text{nom}) - 25$	$0.5 \cdot t_{KHKH} (\text{nom}) + 25$	ps	13,14

Notes:

All parameters are measured from the mid-point of the object signal to the mid-point of the reference signal.

- Parameters apply to CK, $\overline{\text{CK}}$, KD, $\overline{\text{KD}}$.
- Parameter specifies $\uparrow\text{CK} \rightarrow \uparrow\overline{\text{CK}}$ and $\uparrow\overline{\text{KD}} \rightarrow \uparrow\text{KD}$ requirements.
- Parameter specifies $\uparrow\text{CK} \rightarrow \uparrow\text{KD}$ and $\uparrow\overline{\text{CK}} \rightarrow \uparrow\overline{\text{KD}}$ requirements.
- Parameter specifies *Cycle-to-Cycle (C2C) Jitter* (i.e. the maximum variation from clock rising edge to the next clock rising edge). As such, it limits *Period Jitter* (i.e. the maximum variation in clock cycle time from nominal) to $\pm 30\text{ps}$. And as such, it limits *Absolute Jitter* (i.e. the maximum variation in clock rising edge from its nominal position) to $\pm 15\text{ps}$.
- The device can tolerate C2C Jitter greater than 60ps, up to a maximum of 200ps. However, when using a device from a particular speed grade, t_{KHKH} (min) of that speed grade must be derated (increased) by half the difference between the actual C2C Jitter and 60ps. For example, if the actual C2C Jitter is 100ps, then t_{KHKH} (min) for the -133 speed grade is derated to 0.77ns ($0.75\text{ns} + 0.5 \cdot (100\text{ps} - 60\text{ps})$).
- V_{DD} slew rate must be $< 0.1\text{V DC per } 50\text{ns}$ for PLL lock retention. PLL lock time begins once V_{DD} and input clock are stable.
- Parameter applies to CK.
- Parameters apply to Q, and are referenced to $\uparrow\text{CK}$. Applicable when Data Inversion is disabled.
- Parameters apply to Q, QINV, and are referenced to $\uparrow\text{CK}$. Applicable when Data Inversion is enabled.
- Parameter specifies $\uparrow\text{CK} \rightarrow \uparrow\text{CQ}$ timing. Applicable when Data Inversion is disabled.
- Parameter specifies $\uparrow\text{CK} \rightarrow \uparrow\text{CQ}$ timing. Applicable when Data Inversion is enabled.
- Parameters apply to Q, QINV, QVLD and are referenced to $\uparrow\text{CQ}$ & $\uparrow\overline{\text{CQ}}$.
- Parameter specifies $\uparrow\text{CQ} \rightarrow \uparrow\overline{\text{CQ}}$ timing. $t_{KHKH} (\text{nom})$ is the nominal input clock cycle time applied to the device.
- Parameters are not tested. They are guaranteed by design, and verified through extensive corner-lot characterization.

AC Timing Specifications (variable with device speed grade)

Parameter	Symbol	-133		-120		-106		Units	Notes
		Min	Max	Min	Max	Min	Max		
Input Clock Timing									
Clk Cycle Time	t_{KHKH}	0.75	6.0	0.83	6.0	0.9375	6.0	ns	1
Input Setup & Hold Timing									
Input Valid to Clk High	t_{IVKH}	150	—	150	—	150	—	ps	2
Clk High to Input Hold	t_{KHIX}	150	—	150	—	150	—	ps	
Input Pulse Width	t_{IPW}	200	—	200	—	200	—	ps	3
MRW Valid to Clk High	t_{RVKH}	150	—	150	—	150	—	ps	4
Clk High to MRW Hold	t_{KHRX}	150	—	150	—	150	—	ps	

Notes:

All parameters are measured from the mid-point of the object signal to the mid-point of the reference signal.

- Parameters apply to CK, \overline{CK} , KD, \overline{KD} .
- Parameters apply to \overline{SA} , and are referenced to $\uparrow CK$ (and to $\uparrow \overline{CK}$ during Loopback Mode).
Parameters apply to \overline{R} , \overline{W} , and are referenced to $\uparrow CK$ (and to $\uparrow \overline{CK}$ during Loopback Mode).
Parameters apply to D, \overline{DINV} , and are referenced to $\uparrow KD$ & $\uparrow \overline{KD}$.
Parameters apply to KD, \overline{KD} , and are referenced to $\uparrow CK$ & $\uparrow \overline{CK}$ during Loopback Mode.
- Parameter specifies the input pulse width requirements for each individual address, control, and data input. Per-pin deskew must be performed, to center the valid window of each individual input around the clock edge that latches it, in order for this parameter to be relevant to the application. The parameter is not tested; it is guaranteed by design and verified through extensive corner-lot characterization.
- Parameters apply to MRW, and are referenced to $\uparrow CK$. Applicable when Register Write Mode is utilized synchronously.

JTAG Test Mode Description

These devices provide a JTAG Test Access Port (TAP) and Boundary Scan interface using a limited set of IEEE std. 1149.1 functions. This test mode is intended to provide a mechanism for testing the interconnect between master (processor, controller, etc.), ECCRAM, other components, and the printed circuit board. In conformance with a subset of IEEE std. 1149.1, these devices contain a TAP Controller and multiple TAP Registers. The TAP Registers consist of one Instruction Register and multiple Data Registers.

The TAP consists of the following four signals:

Pin	Pin Name	I/O	Description
TCK	Test Clock	I	Induces (clocks) TAP Controller state transitions.
TMS	Test Mode Select	I	Inputs commands to the TAP Controller. Sampled on the rising edge of TCK.
TDI	Test Data In	I	Inputs data serially to the TAP Registers. Sampled on the rising edge of TCK.
TDO	Test Data Out	O	Outputs data serially from the TAP Registers. Driven from the falling edge of TCK.

Concurrent TAP and Normal ECCRAM Operation

According to IEEE std. 1149.1, most public TAP Instructions do not disrupt normal device operation. In these devices, the only exceptions are EXTEST and SAMPLE-Z. See the Tap Registers section for more information.

Disabling the TAP

When JTAG is not used, TCK should be tied Low to prevent clocking the ECCRAM. TMS and TDI should either be tied High through a pull-up resistor or left unconnected. TDO should be left unconnected.

JTAG DC Operating Conditions

Parameter	Symbol	Min	Max	Units	Notes
JTAG Input High Voltage	V_{TIH}	$0.75 * V_{DDQ}$	$V_{DDQ} + 0.15$	V	1
JTAG Input Low Voltage	V_{TIL}	-0.15	$0.25 * V_{DDQ}$	V	1
JTAG Output High Voltage	V_{TOH}	$V_{DDQ} - 0.2$	—	V	2, 3
JTAG Output Low Voltage	V_{TOL}	—	0.2	V	2, 4

Notes:

- Parameters apply to TCK, TMS, and TDI.
- Parameters apply to TDO.
- $I_{TOH} = -2.0$ mA.
- $I_{TOL} = 2.0$ mA.

JTAG AC Timing Specifications

Parameter	Symbol	Min	Max	Units
TCK Cycle Time	t_{THTH}	50	—	ns
TCK High Pulse Width	t_{THTL}	20	—	ns
TCK Low Pulse Width	t_{TLTH}	20	—	ns
TMS Setup Time	t_{MVTH}	10	—	ns
TMS Hold Time	t_{THMX}	10	—	ns
TDI Setup Time	t_{DVTH}	10	—	ns
TDI Hold Time	t_{THDX}	10	—	ns
Capture Setup Time (Address, Control, Data, Clock)	t_{CS}	10	—	ns
Capture Hold Time (Address, Control, Data, Clock)	t_{CH}	10	—	ns
TCK Low to TDO Valid	t_{TLOV}	—	10	ns
TCK Low to TDO Hold	t_{TLOX}	0	—	ns

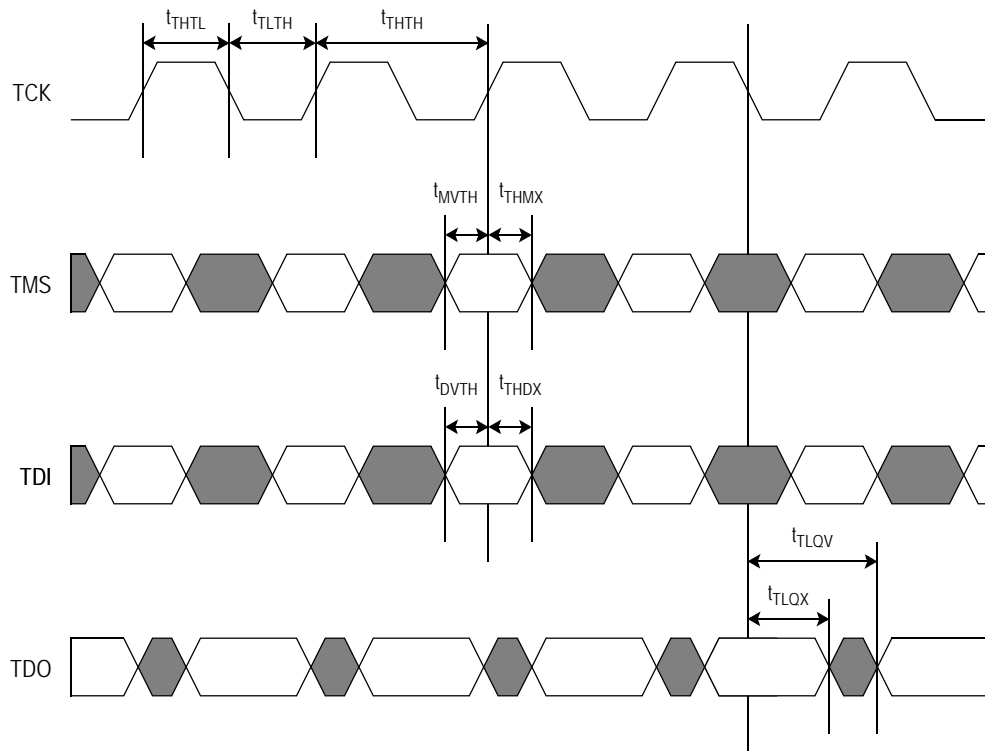
JTAG Timing Diagram

TAP Controller

The TAP Controller is a 16-state state machine that controls access to the various TAP Registers and executes the operations associated with each TAP Instruction. State transitions are controlled by TMS and occur on the rising edge of TCK.

The TAP Controller enters the Test-Logic Reset state in one of two ways:

1. At power up.
2. When a logic 1 is applied to TMS for at least 5 consecutive rising edges of TCK.

The TDI input receiver is sampled only when the TAP Controller is in either the Shift-IR state or the Shift-DR state.

The TDO output driver is enabled only when the TAP Controller is in either the Shift-IR state or the Shift-DR state.

TAP Controller State Diagram

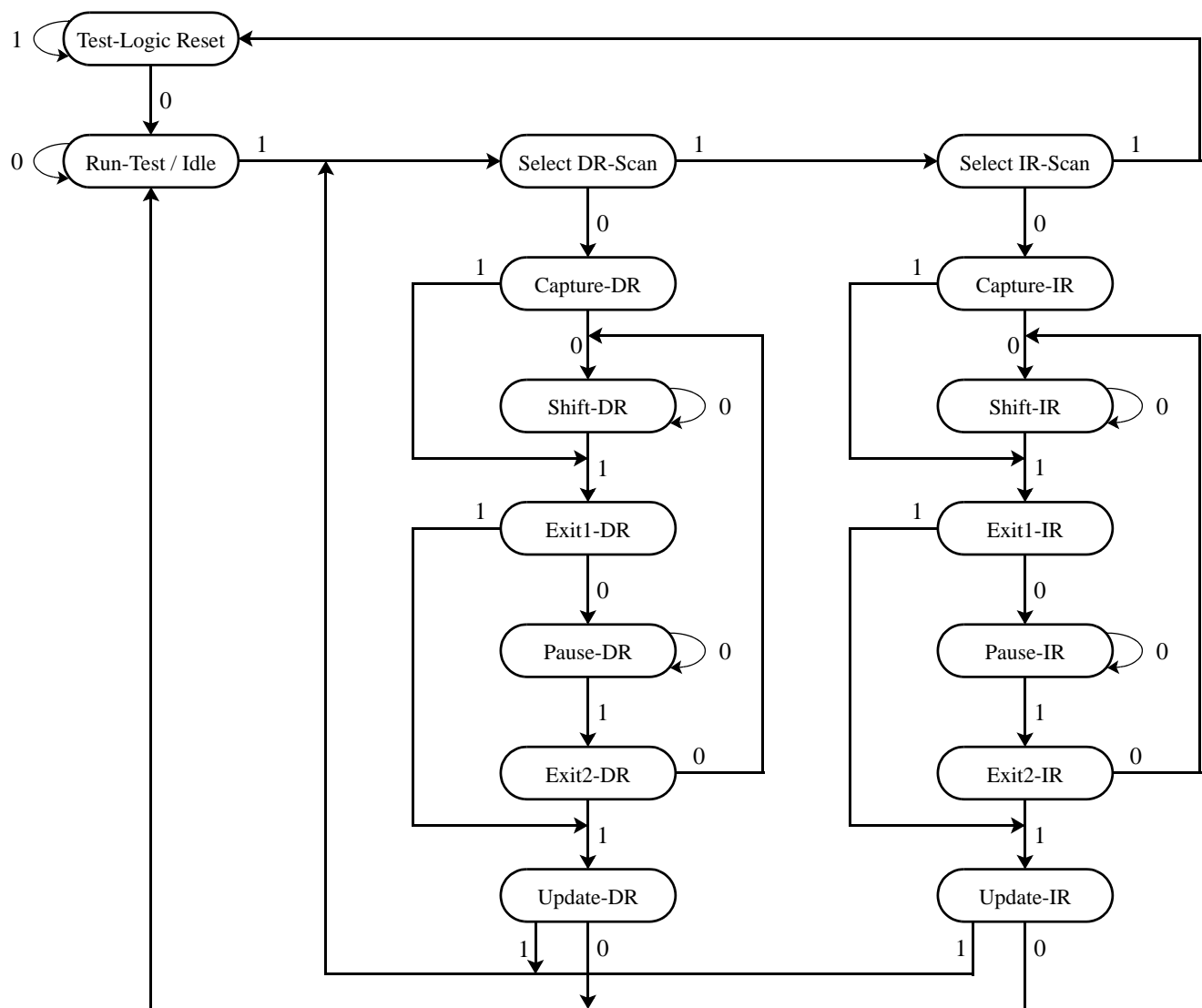

TAP Registers

TAP Registers are serial shift registers that capture serial input data (from TDI) on the rising edge of TCK, and drive serial output data (to TDO) on the subsequent falling edge of TCK. They are divided into two groups: Instruction Registers (IR), which are manipulated via the IR states in the TAP Controller, and Data Registers (DR), which are manipulated via the DR states in the TAP Controller.

Instruction Register (IR - 3 bits)

The Instruction Register stores the various TAP Instructions supported by ECCRAM. It is loaded with the IDCODE instruction (logic 001) at power-up, and when the TAP Controller is in the Test-Logic Reset and Capture-IR states. It is inserted between TDI and TDO when the TAP Controller is in the Shift-IR state, at which time it can be loaded with a new instruction. However, newly loaded instructions are not executed until the TAP Controller has reached the Update-IR state.

The Instruction Register is 3 bits wide, and is encoded as follows:

Code (2:0)	Instruction	Description
000	EXTEST	Loads the logic states of all signals composing the ECCRAM I/O ring into the Boundary Scan Register when the TAP Controller is in the Capture-DR state, and inserts the Boundary Scan Register between TDI and TDO when the TAP Controller is in the Shift-DR state. Also transfers the contents of the Boundary Scan Register associated with output signals (Q, QINV, QVLD, CQ, CQ) directly to their corresponding output pins. However, newly loaded Boundary Scan Register contents do not appear at the output pins until the TAP Controller has reached the Update-DR state. Also disables all ODT. See the Boundary Scan Register description for more information.
001	IDCODE	Loads a predefined device- and manufacturer-specific identification code into the ID Register when the TAP Controller is in the Capture-DR state, and inserts the ID Register between TDI and TDO when the TAP Controller is in the Shift-DR state. See the ID Register description for more information.
010	SAMPLE-Z	Loads the logic states of all signals composing the ECCRAM I/O ring into the Boundary Scan Register when the TAP Controller is in the Capture-DR state, and inserts the Boundary Scan Register between TDI and TDO when the TAP Controller is in the Shift-DR state. Also disables all ODT. Also forces Q, QINV output drivers to a High-Z state. See the Boundary Scan Register description for more information.
011	PRIVATE	Reserved for manufacturer use only.
100	SAMPLE	Loads the logic states of all signals composing the ECCRAM I/O ring into the Boundary Scan Register when the TAP Controller is in the Capture-DR state, and inserts the Boundary Scan Register between TDI and TDO when the TAP Controller is in the Shift-DR state. See the Boundary Scan Register description for more information.
101	PRIVATE	Reserved for manufacturer use only.
110	PRIVATE	Reserved for manufacturer use only.
111	BYPASS	Loads a logic 0 into the Bypass Register when the TAP Controller is in the Capture-DR state, and inserts the Bypass Register between TDI and TDO when the TAP Controller is in the Shift-DR state. See the Bypass Register description for more information.

Bypass Register (DR - 1 bit)

The Bypass Register is one bit wide, and provides the minimum length serial path between TDI and TDO. It is loaded with a logic 0 when the BYPASS instruction has been loaded in the Instruction Register and the TAP Controller is in the Capture-DR state. It is inserted between TDI and TDO when the BYPASS instruction has been loaded into the Instruction Register and the TAP Controller is in the Shift-DR state.

ID Register (DR - 32 bits)

The ID Register is loaded with a predetermined device- and manufacturer-specific identification code when the IDCODE instruction has been loaded into the Instruction Register and the TAP Controller is in the Capture-DR state. It is inserted between TDI and TDO when the IDCODE instruction has been loaded into the Instruction Register and the TAP Controller is in the Shift-DR state.

The ID Register is 32 bits wide, and is encoded as follows:

See BSDL Model (31:12)	GSI ID (11:1)	Start Bit (0)
XXXX XXXX XXXX XXXX XXXX	0001 1011 001	1

Bit 0 is the LSB of the ID Register, and Bit 31 is the MSB. When the ID Register is selected, TDI serially shifts data into the MSB, and the LSB serially shifts data out through TDO.

Boundary Scan Register (DR - 137 bits)

The Boundary Scan Register is equal in length to the number of active signal connections to the ECCRAM (excluding the TAP pins) plus a number of place holder locations reserved for functional and/or density upgrades. It is loaded with the logic states of all signals composing the ECCRAM's I/O ring when the EXTEST, SAMPLE, or SAMPLE-Z instruction has been loaded into the Instruction Register and the TAP Controller is in the Capture-DR state. It is inserted between TDI and TDO when the EXTEST, SAMPLE, or SAMPLE-Z instruction has been loaded into the Instruction Register and the TAP Controller is in the Shift-DR state.

Additionally, the contents of the Boundary Scan Register associated with the ECCRAM outputs (Q, QINV, QVLD, CQ, \overline{CQ}) are driven directly to the corresponding ECCRAM output pins when the EXTEST instruction is selected. However, after the EXTEST instruction has been selected, any new data loaded into Boundary Scan Register when the TAP Controller is in the Shift-DR state does not appear at the output pins until the TAP Controller has reached the Update-DR state.

The value captured in the boundary scan register for NU pins is determined by the external pin state. The value captured in the boundary scan register for NC pins is 0 regardless of the external pin state. The value captured in the Internal Cell (Bit 137) is 1.

Output Driver State During EXTEST

EXTEST allows the Internal Cell (Bit 137) in the Boundary Scan Register to control the state of Q, QINV drivers. That is, when Bit 137 = 1, Q, QINV drivers are enabled (i.e., driving High or Low), and when Bit 137 = 0, Q, QINV drivers are disabled (i.e., forced to High-Z state). See the Boundary Scan Register section for more information.

ODT State During EXTEST and SAMPLE-Z

ODT on all inputs is disabled during EXTEST and SAMPLE-Z.

Boundary Scan Register Bit Order Assignment

The table below depicts the order in which the bits are arranged in the Boundary Scan Register. Bit 1 is the LSB and Bit 137 is the MSB. When the Boundary Scan Register is selected, TDI serially shifts data into the MSB, and the LSB serially shifts data out through TDO.

Bit	Pad	Bit	Pad	Bit	Pad	Bit	Pad	Bit	Pad
1	7L	29	13E	57	13V	85	2W	113	2F
2	7K	30	10F	58	11V	86	3V	114	4F
3	9L	31	12F	59	12W	87	1V	115	1E
4	9K	32	11G	60	10W	88	4U	116	3E
5	8J	33	13G	61	12Y	89	2U	117	2D
6	7H	34	10G	62	10Y	90	3T	118	4D
7	9H	35	12G	63	8V	91	1T	119	1C
8	7G	36	11H	64	9U	92	4R	120	3C
9	8G	37	13H	65	8T	93	2R	121	2B
10	9F	38	10J	66	9R	94	3P	122	4B
11	8E	39	12J	67	8P	95	1P	123	2A
12	7D	40	13K	68	9N	96	4P	124	4A
13	9D	41	13L	69	8M	97	2P	125	5A
14	8C	42	11L	70	6M	98	3N	126	6A
15	7B	43	12M	71	7N	99	1N	127	6B
16	8B	44	10M	72	5N	100	4M	128	6C
17	9B	45	13N	73	7P	101	2M	129	5D
18	7A	46	11N	74	6P	102	3L	130	6E
19	9A	47	12P	75	5R	103	1L	131	5F
20	10A	48	10P	76	6T	104	1K	132	6G
21	12A	49	13P	77	7U	105	2J	133	5H
22	10B	50	11P	78	5U	106	4J	134	6J
23	12B	51	12R	79	6V	107	1H	135	5K
24	11C	52	10R	80	6W	108	3H	136	5L
25	13C	53	13T	81	7Y	109	2G	137	Internal
26	10D	54	11T	82	4Y	110	4G		
27	12D	55	12U	83	2Y	111	1G		
28	11E	56	10U	84	4W	112	3G		

260-Pin BGA Package Drawing (Package GK)

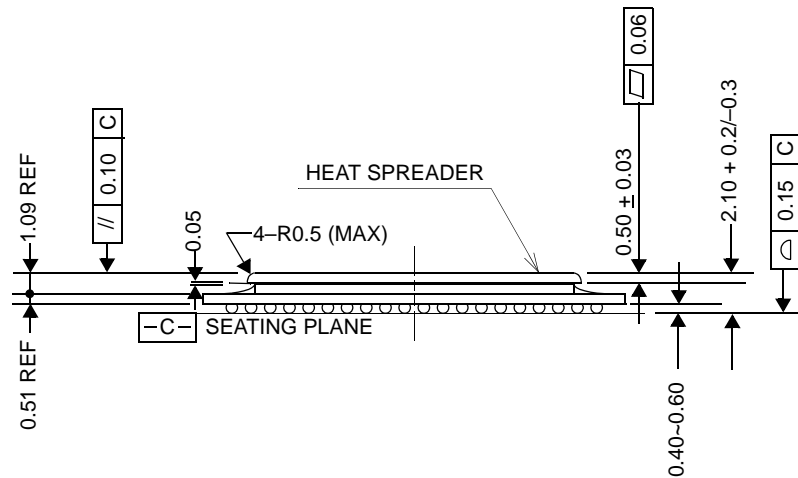
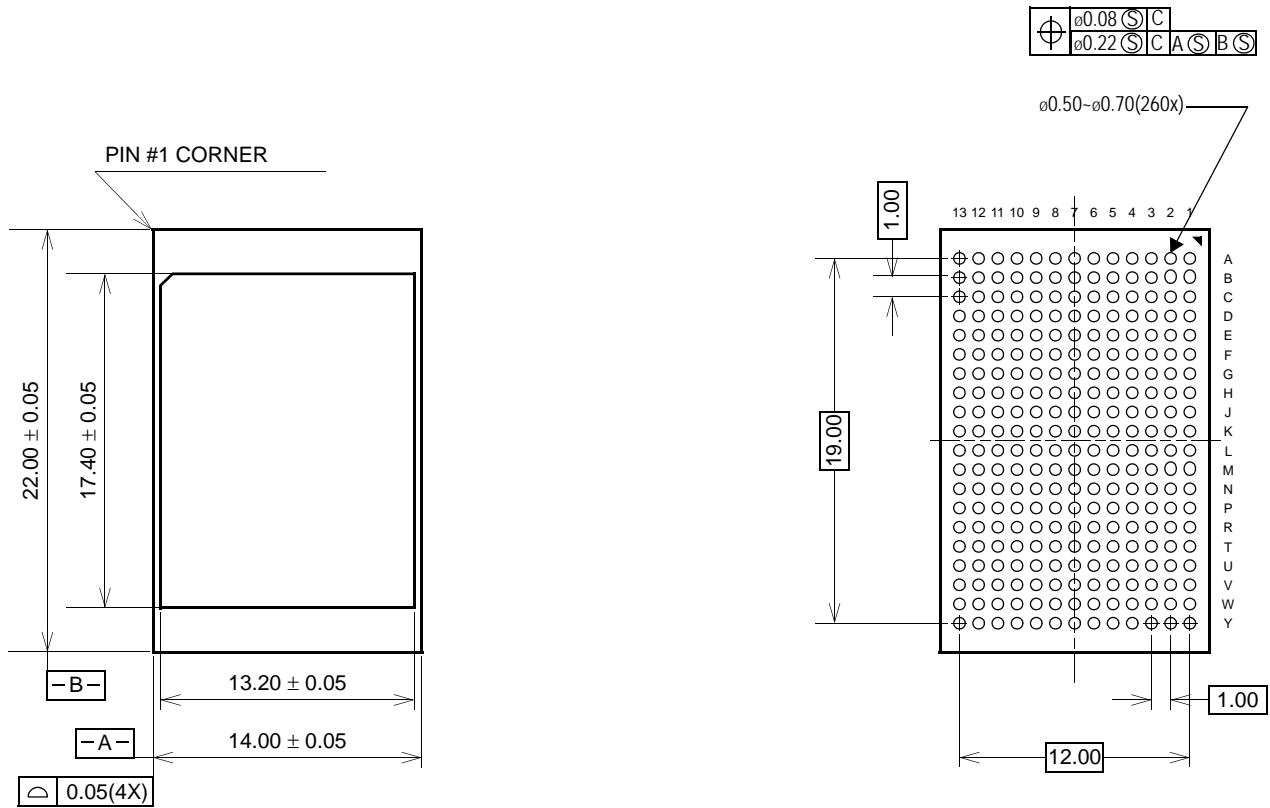

Ball Pitch:	1.00	Substrate Thickness:	0.51
Ball Diameter:	0.60	Mold Thickness:	—

Ordering Information — GSI SigmaQuad-IVe ECCRAM

Org	Part Number	Type	Package	Speed (MHz)	T _A
8M x 18	GS81314PD18GK-133	SigmaQuad-IVe B4	ROHS-Compliant 260-Pin BGA	1333	C
8M x 18	GS81314PD18GK-120	SigmaQuad-IVe B4	ROHS-Compliant 260-Pin BGA	1200	C
8M x 18	GS81314PD18GK-106	SigmaQuad-IVe B4	ROHS-Compliant 260-Pin BGA	1066	C
8M x 18	GS81314PD18GK-133I	SigmaQuad-IVe B4	ROHS-Compliant 260-Pin BGA	1333	I
8M x 18	GS81314PD18GK-120I	SigmaQuad-IVe B4	ROHS-Compliant 260-Pin BGA	1200	I
8M x 18	GS81314PD18GK-106I	SigmaQuad-IVe B4	ROHS-Compliant 260-Pin BGA	1066	I
4M x 36	GS81314PD36GK-133	SigmaQuad-IVe B4	ROHS-Compliant 260-Pin BGA	1333	C
4M x 36	GS81314PD36GK-120	SigmaQuad-IVe B4	ROHS-Compliant 260-Pin BGA	1200	C
4M x 36	GS81314PD36GK-106	SigmaQuad-IVe B4	ROHS-Compliant 260-Pin BGA	1066	C
4M x 36	GS81314PD36GK-133I	SigmaQuad-IVe B4	ROHS-Compliant 260-Pin BGA	1333	I
4M x 36	GS81314PD36GK-120I	SigmaQuad-IVe B4	ROHS-Compliant 260-Pin BGA	1200	I
4M x 36	GS81314PD36GK-106I	SigmaQuad-IVe B4	ROHS-Compliant 260-Pin BGA	1066	I

Note: C = Commercial Temperature Range. I = Industrial Temperature Range.

Revision History

Rev. Code	Types of Changes Format or Content	Revisions
GS81314PD1836GK_r1	—	<ul style="list-style-type: none"> • Creation of new datasheet
GS81314PD1836GK_r1.01	Content	<ul style="list-style-type: none"> • Changed Loopback Latency to 7 cycles, regardless of Read Latency.
GS81314PD1836GK_r1.02	Content	<ul style="list-style-type: none"> • Removed leaded BGA package support.
GS81314PD1836GK_r1.03	Content	<ul style="list-style-type: none"> • Removed 4th digit from all speed bins.
GS81314PD1836GK_r1.04	Content	<ul style="list-style-type: none"> • Redefined Bank Address pins.
GS81314PD1836GK_r1.05	Content	<ul style="list-style-type: none"> • Increased V_{DD} (max) to 1.35V. • Added package thermal impedances. • Redefined OFR[2:0] bits in Configuration Reg #1 as RSVD[2:0]. • Revised t_{KHKDH} specs. • Revised t_{KHQV}, t_{KHQX}, and t_{KHCQH} specs. • Revised t_{CQHQV} and t_{CQHQX} specs. • Revised t_{IPW} specs. • Banner changed to "Preliminary", to reflect ES status.
GS81314PD1836GK_r1.06	Content	<ul style="list-style-type: none"> • Add I_{DD} specifications. • Changed -125 speed bin to -120. Changed -110 speed bin to -106. Removed -100 speed bin. • Removed RL=5 support (created new RL=5 -specific datasheet with no bank restrictions; see GS81314PD1937GK).
GS81314PD1836GK_r1.07	Content	<ul style="list-style-type: none"> • Reduced V_{DD} (min) requirement for -120 speed bin to 1.15V, to allow for 1.2V nominal V_{DD}.
GS81314PD1836GK_r1.08	Content	<ul style="list-style-type: none"> • Removed "Preliminary" from data sheets.
GS81314PD1836GK_r1.09	Content	<ul style="list-style-type: none"> • Increased V_{DD} (min) to 1.2V for 1066 MHz and 1200 MHz speed bins. V_{DD} (min) is now the same value for all speed bins.