

### Features and Benefits

- Suitable for 1mm automotive PMMA Plastic Optical Fiber (POF).
- Includes 650nm LED and a PIN photodiode.
- Product is qualified following Automotive Application Recommendation for optical MOST® interfaces
- Ambient operating Temperature Range [-40°C to 95°C]
- Data Communication rate up to 25 Mb/s (biphase) and 50 Mb/s (non return to zero).
- Robust rejection of electromagnetic interference (EMI) due to full integration of the photo detector within the receiver IC
- Compliant with Laser Class 1 Product Standard

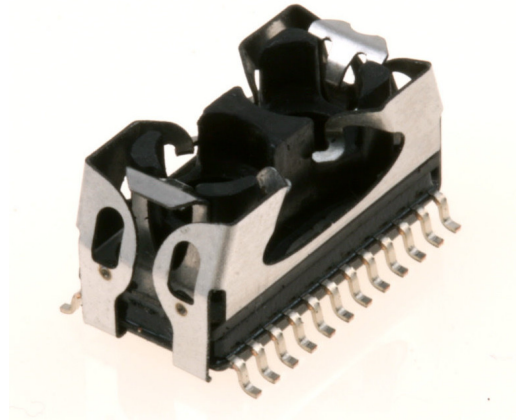

### Ordering Information

Part No.	Temperature Code	Package Code	Option code	Packing
MLX75608	P (-40°C to 95°C)	XV (SOIC24 for MOST)	AAA-001	TU (tube)
MLX75608	P (-40°C to 95°C)	XV (SOIC24 for MOST)	AAA-001	RE (reel)

Example: MLX75608PXV-AAA-001-RE

### Application Examples

Automotive infotainment networks: e.g. rear seat entertainment, navigation system, car radio, Vision enhancement systems.  
 Audio/Video Data transmission.  
 Multimedia / telematics systems.  
 ...

### Functional Diagram

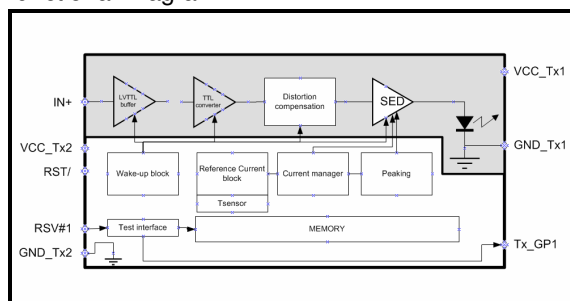

25Mbps Transmitter

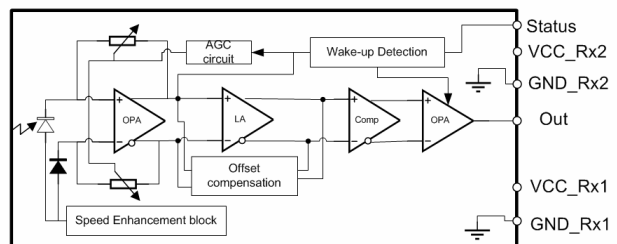

25Mbps Receiver

### ***General Description***

The 25Mbps Transceiver package is a SOIC-type package with a photo transmitter IC and a photo receiver IC developed for communication on PMMA Plastic Optical Fiber (POF) at a speed up to 25 Mb/s (bi-phase) or 50 Mb/s (non return to zero).

The optical transmitter houses a LED driver and a 650 nm Light Source die. The Light Source drive current is optimized to obtain the maximum extinction ratio between the 1 and 0 light levels. The Light Source modulation current is fully programmable in absolute value over the full temperature range. This feature allows trimming of the optical emitted power within a narrow range at any temperature, hence giving rise to an enhanced optical budget. In addition the trimming capability over temperature allows full compensation of the temperature dependence of the Light Source optical efficiency. In addition also an m3dB function is available for testing the application. This function allows reduction of the output power by a factor of two. Checking the link integrity with enabled m3dB function guarantees at least a 3dB guard band when the link is in normal operating mode with disabled m3dB function.

The optical receiver is implemented as one monolithic Integrated Circuit, which combines with a PIN photo detector with a TIA, limiting amplifier and an LVTTTL output stage. This receiver circuit operates at 50 Mbps speed and automatically controls its gain over a wide range of optical power.

The optical receiver embeds a wake-up function. When the optical input signal is detected, the circuit puts itself out of sleep mode.

The circuit flags its sleeping mode activation via the STATUS pin, which is set at HIGH state. During valid operation, STATUS pin is set at LOW state.

### Table of Content

<b>Application Examples</b> .....	<b>1</b>
<b>General Description</b> .....	<b>2</b>
<b>Glossary of Terms</b> .....	<b>4</b>
<b>Maximum Ratings</b> .....	<b>4</b>
<b>Recommended Operating Conditions</b> .....	<b>4</b>
<b>Recommended Networks Conditions</b> .....	<b>4</b>
<b>Transmitter part DC Characteristics</b> .....	<b>5</b>
<b>Transmitter part AC Characteristics</b> .....	<b>5</b>
<b>Transmitter part Optical Specifications</b> .....	<b>6</b>
<b>Receiver part DC Characteristics</b> .....	<b>6</b>
<b>Receiver part AC Characteristics</b> .....	<b>7</b>
<b>Receiver part Optical Specifications</b> .....	<b>7</b>
<b>General Description</b> .....	<b>8</b>
<i>Optical part</i> .....	8
<i>Block Diagram</i> .....	8
<b>Pin Definitions and Descriptions</b> .....	<b>10</b>
<b>Package Outline</b> .....	<b>11</b>
<i>Package Parameters</i> .....	11
<i>Package Drawing</i> .....	13
<i>Footprint</i> .....	14
<i>Lead frame</i> .....	14
<b>Unique Features</b> .....	<b>14</b>
<b>Recommended fiber ferrules</b> .....	<b>14</b>
<b>Protection cap</b> .....	<b>15</b>
<b>Reliability Information</b> .....	<b>16</b>
<b>Manufacturing Information</b> .....	<b>16</b>
<i>Soldering Process</i> .....	16

**Precaution** ..... 17

*Optical opening precautions*..... 17

*ESD Precautions* ..... 17

**Disclaimer**..... 18

### Glossary of Terms

MOST	Media Oriented Transport
EOC	Electrical to Optical Converter
LVTTTL	Low Voltage Transistor-Transistor Logic
dBm	Decibel referred to 1 milli-watt
A <sub>PWD</sub>	Average Pulse Width Distortion
P <sub>av</sub>	Average Optical Power
ESD	Electro Static Discharge
TIA	Trans Impedance Amplifier
UI	Unit Interval
RoHs	Restriction Of the use of certain Hazardous Substances

### Maximum Ratings

Parameter.	Symbol	Min	Max	Units
Storage Temperature Range	T <sub>STG</sub>	-40	100	°C
Junction Temperature	T <sub>J</sub>	-40	105	°C
Power Dissipation	P <sub>TOT</sub>	-	380	mW
Power Supply Voltage	VCC <sub>Max</sub>	-0.5	7	V
ESD Level ( Human Body Model)	ESD	2		kV

### Recommended Operating Conditions

Parameter.	Symbol	Min	Typ	Max	Units
Operating Supply Voltage	VCC	3.135	3.3	3.465	V
Operating Ambient Temperature Range	T <sub>AMB</sub>	-40	-	95	°C

### Recommended Networks Conditions

Parameter.	Symbol	Min	Typ	Max	Units
Bit rate (Bi-phase mark)	BR	4	22.6	25	Mbps
Unit Interval	UI	-	22.14	-	ns
Minimum bit length	B <sub>length</sub>		2	-	UI
DC Adaptive coding period	t <sub>DCA</sub>	-	-	5	UI

### Transmitter part DC Characteristics

DC Operating Parameters  $T_A = -40^{\circ}\text{C}$  to  $95^{\circ}\text{C}$ ,  $V_{CC} = 3.135\text{V}$  to  $3.465\text{V}$  (unless otherwise specified)

Parameter.	Symbol	Test Conditions	Min	Typ	Max	Units
Low level input voltage (JESD8C LVTTTL)	$V_{IL}$		-0.3	-	0.8	V
High level input voltage (JESD8C LVTTTL)	$V_{IH}$		2.0	-	$V_{CC} + 0.3$	V
Input Current	$I_{IN}$		-	-	20	$\mu\text{A}$
Supply current (electrical power on mode)	$I_{DDO}$		-	22	50	mA
M3dB pin impedance	$Z_{Ctrl}$		0.3		2	$\text{M}\Omega$

### Transmitter part AC Characteristics

AC Operating Parameters  $T_A = -40^{\circ}\text{C}$  to  $95^{\circ}\text{C}$ ,  $V_{CC} = 3.135\text{V}$  to  $3.465\text{V}$

Parameter.	Symbol	Test Conditions	Min	Typ	Max	Units
Optical Power Up Delay	Ton2		-	-	100	$\mu\text{s}$
Optical Power Down Delay	Toff2		-	-	2	$\mu\text{s}$
Rise Time	$T_r$	Measured between 20%-80% of signal	-	-	0.25	UI
Fall Time	$T_f$	Measured between 20%-80% of signal	-	-	0.25	UI
Pulse-width-variation	$T_{pww2}$	Measured at 50% of signal amplitude And SP1 PWV within 0.955UI~1.045UI	0.903	-	1.097	UI
Average Pulse Width Distortion	$T_{apwd2}$	Measured at 50% of signal amplitude And SP1 $A_{pwd}$ within +/-0.023UI	-0.063	-	0.063	UI
Data Dependent Jitter	$J_{ddj2}$	Measured with 0.01UI data dependent jitter on SP1 signal	-	-	0.035	UI
Uncorrelated Jitter	$J_{uj2}$	Measured with 0.0045UI uncorrelated jitter on SP1 signal	-	-	0.015	UI
Positive overshoot	Over_p1	Within 0 ~ 2/3UI	-20	-	40	%
Negative Overshoot	Over_n	Within -1 ~ -1/4UI	-10	-	20	%
High level signal ripple	Over_p2	Within 2/3 ~ 3/4UI Within 2/3 ~ (1+3/4)UI Within 2/3 ~ (2+3/4)UI	-10	-	10	%
Frequency threshold for optical output activation	$F_{on2}$		-	-	1	MHz

### Transmitter part Optical Specifications

DC Operating Parameters  $T_A = -40^{\circ}\text{C}$  to  $95^{\circ}\text{C}$ ,  $V_{CC} = 3.135\text{V}$  to  $3.465\text{V}$

Parameter	Symbol	Test Conditions	Min	Typ	Max	Units
Center Wavelength	$\lambda_{c2}$		635	650	675	nm
Spectral Width (RMS)	$\sigma_{\lambda 2}$		-	-	17	nm
Average optical power emitted by the Transmitter component <sup>(1,2)</sup>	$P_{av}$	1) Power within a far field angle of $30^{\circ}$ (NA=0.5) 2) within a diameter of 1.0mm	-8.5	-	0.0	dBm
Extinction ratio	ER	Measured with 5UI pulse width	10	-	-	dB
3dB attenuation of optical output <sup>(3)</sup>	$P_{M3dB}$	M3dB is HIGH state	2.5	3	3.5	dB
Optical output power "Light off"	$P_{off}$		-	-	-50	dBm
Misalignment between light source center and the center of the Ferrule coupling hole.	$\Delta_{xy}$		0	-	35	$\mu\text{m}$
Distance between top of light source and Ferrule stopper top plate of package in the ferrule coupling hole	$\Delta_z$		-	-	150	$\mu\text{m}$

1) Taking into account a fiber pigtail attenuation of at least 1.5dB, the max emitted optical power is limited to -1.5dBm.

2) The fiber pigtail loss of 1.5dB is also necessary not to violate the eye safety limit

(3) AC performance isn't guaranteed when M3dB function is activated.

### Receiver part DC Characteristics

DC Operating Parameters  $T_A = -40^{\circ}\text{C}$  to  $95^{\circ}\text{C}$ ,  $V_{CC} = 3.135\text{V}$  to  $3.465\text{V}$  (unless otherwise specified)

Parameter	Symbol	Test Conditions	Min	Typ	Max	Units
Low level output voltage (JEDEC8C LVTTTL)	$V_{OL}$	$R_L = 50\text{k}\Omega$	0	-	0.4	V
High level output voltage (JEDEC8C LVTTTL)	$V_{OH}$	$R_L = 50\text{k}\Omega$	2.5	-	$V_{CC} + 0.3$	V
Supply current (Operating Mode)	$I_{CCO}$	Light on	-	22	30	mA
Supply Current (Sleeping Mode)	$I_{CCS}$	Light off with $50\text{k}\Omega$ output load	-	-	30	$\mu\text{A}$

### Receiver part AC Characteristics

DC Operating Parameters  $T_A = -40^{\circ}\text{C}$  to  $95^{\circ}\text{C}$ ,  $V_{CC} = 3.135\text{V}$  to  $3.465\text{V}$

Parameter	Symbol	Test Conditions	Min	Typ	Max	Units
Power Supply Rejection Ratio	PSSR		-	30	-	dB
Output Rise Time	$t_{R4}$	$R_L=50\text{k}\Omega/10\text{pF}$ Measured between 10%-90% of signal	-	-	0.45	UI
Output Fall Time	$t_{F4}$	$R_L=50\text{k}\Omega/10\text{pF}$ Measured between 10%-90% of signal	-	-	0.45	UI
Data Dependent Jitter	$J_{ddj4}$	Measured with 0.035UI data dependent jitter on SP3 signal	-	-	0.15	UI
Uncorrelated Jitter	$J_{uj4}$	Measured with 0.015UI uncorrelated jitter on SP3 signal	-	-	0.045	UI
Pulse Width Variation	$T_{pww4}$	Measured at 50% of signal amplitude And SP3 PWV within 0.903UI~1.097UI	0.743	-	1.4	UI
Average Pulse width Distortion	$T_{apwd4}$	Measured at 50% of signal amplitude And SP3 $A_{pww}$ within +/-0.063UI	-0.15	-	0.316	UI
Frequency threshold for output release	$F_{on4}$		-	-	1	MHz

### Receiver part Optical Specifications

DC Operating Parameters  $T_A = -40^{\circ}\text{C}$  to  $95^{\circ}\text{C}$ ,  $V_{CC} = 3.135\text{V}$  to  $3.465\text{V}$

Parameter	Symbol	Test Conditions	Min	Typ	Max	Units
Photosensitivity Spectral Range	$\lambda$		630	650	685	nm
Acceptable Extinction ratios of optical input signal	ER		10	-	-	dB
Receivable average optical power for data recovery when in operational mode	$S_{AVinf}$		-24.5	-	-2	dBm
Wake-up optical power threshold	$P_{on}$	Average optical power	-35	-	-29	dBm
Sleep optical power threshold	$P_{off}$	Average optical power	-29	-	-25.5	dBm

### General Description

#### Optical part

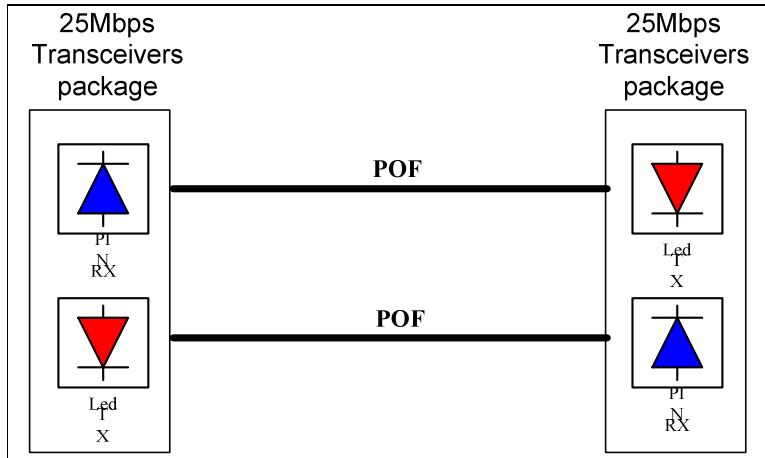

Optical specification is based on:

- Receiver: Silicon Embedded PIN photodiode type with  $0.95\text{mm}^2$  active area.
- Transmitter: 650 nm LED with  $83\mu\text{m}$  aperture.

#### Block Diagram

Light source driver consists of three main blocks: Input buffer, Output driver, and Current source. The current source can be trimmed over process variations of LED and the LED driver IC and also compensates the variation of optical output of the light source with temperature. A 50% power control allows sending only half modulation current to the LED. The test register and memory blocks are used for Melexis to obtain high test coverage during component test and in order to be able to trim the component.

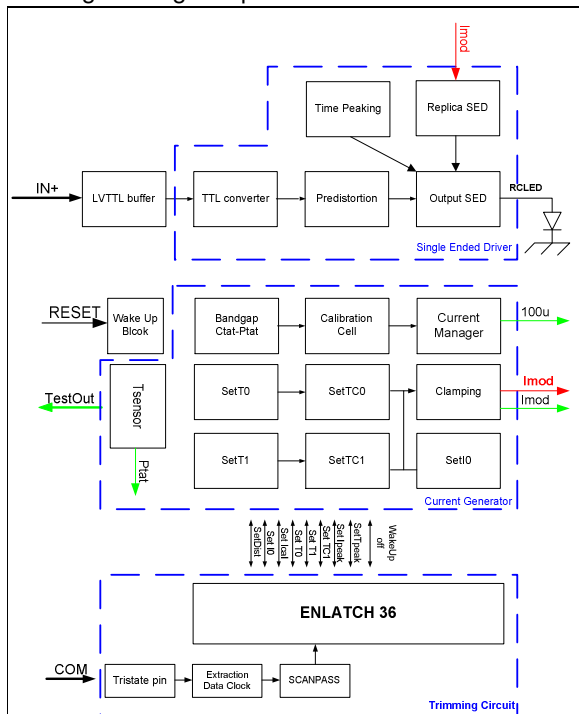

Receiver is based on front-end block (TIA) with a large illuminated photodiode and the second blind photodiode. Both photodiodes have the same shape and size. This front end is controlled by automatic gain control circuitry to gain same performance over light full range. A second stage is responsible for detecting light variations and is able to remove common mode and DC offset. Last stage is used as an output buffer. In addition one block is available to detect light for status pin and a second one is used for fault detection. High test coverage is guaranteed by test modes which can be activated at die or package level, based on dedicated patterns on Melexis production line.

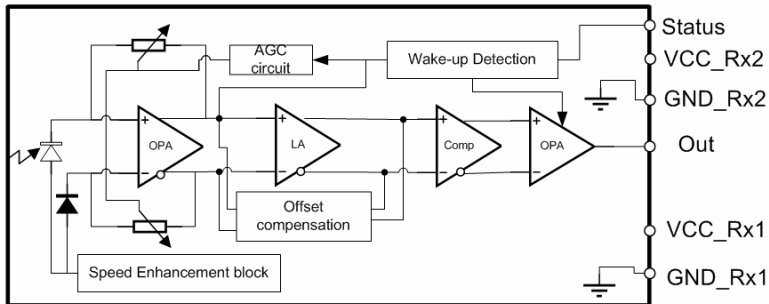

### Pin Definitions and Descriptions

All pins related to primary functions are placed on left side of the package, to allow more flexibility for PCB floor plan. All dedicated and options pins are placed on the right side of the package. Pin 1 is located on the left side of the orientation dot as shown in diagram.

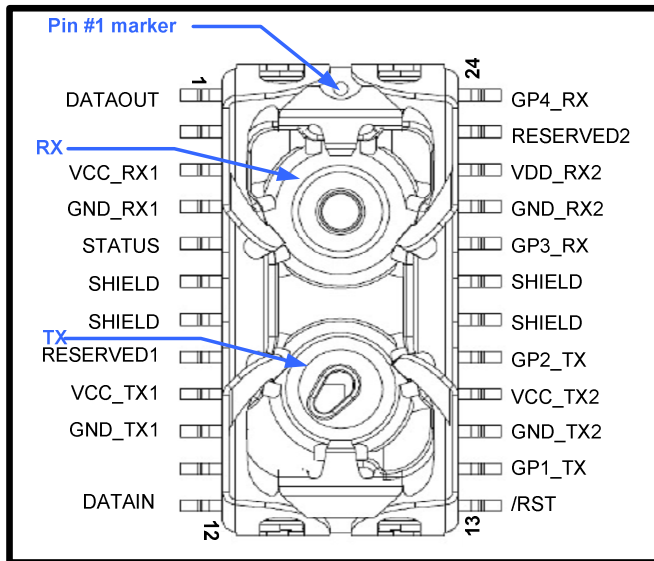

Pin Number	Pin name	Description
1	DataOUT	LVTTTL Data Output
2	NC.	Not Connected
3	VCC_Rx1	Supply voltage for Receiver
4	GND_Rx1	Ground for Receiver
5	STATUS	This pin is only put on "LOW" when the following two conditions are met: modulated light is received <b>and</b> the received data rate is within the operation frequency range. The status pin is used in the application to switch on or off the power supply of the application, where the MOST transceiver is part of.
6	Shield	Shield pin connected to die pad of package
7	Shield	Shield pin connected to die pad of package
8	Reserved1	M3dB function. Should be Connected to GND through 0-Ω resistor if M3dB function isn't used <sup>(1)</sup> . Used for factory test purpose.
9	VCC_Tx1	Supply voltage for Transmitter
10	GND_Tx1	Ground for Transmitter
11	NC	Not Connected
12	DataIN	LVTTTL Data Input
13	/RST	Optical Output power disabling.

14	GP1_Tx1	Currently used for Test output pin. Should be left unconnected
15	GND_Tx2	Ground for Transmitter
16	VCC_TX2	Supply voltage for Transmitter
17	GP2_Tx	Unconnected pin
18	Shield	Shield pin connected to die pad of package
19	Shield	Shield pin connected to die pad of package
20	GP3_RX	Automatic Gain Control analog output and Factory test output Should be left unconnected
21	GND_Rx2	Ground for Receiver
22	VCC_Rx2	Supply voltage for Receiver
23	Reserved2	Connect to VCC_RX2 through 0-Ω resistor. Used for factory test purpose.
24	GP4_RX	Should be left unconnected.

(1) AC performance isn't guaranteed when M3dB function is activated

### Package Outline

Package solution gains advantage by fully encapsulating the receiver and transmitter die. The available 2 optical openings allow the light to enter and leave both dies. Openings are designed with a conical shape to receive the POF ferrule.

Top part is used as guiding structure, allowing improvement versus misalignment and tilt. An additional metal structure is placed on the top part to ensure ferrule clamping.

This ferrule clamping system allows blocking and maintaining ferrule against the bottom part by a spring effect. Moreover, it allows rework by easy removal of the ferrule out of the guiding structure.

Cavity depth is currently at 3.2mm, allowing low fiber tilt and accurate alignment.

Hole diameters are different. One is at 3.55mm for transmitter side and the other is 3.15mm for receiver side with dedicated ferrule receptacle shape, allowing mistake proofing (Poka-Yoke). Cavity pitch is fixed at 6mm.

### Package Parameters

Parameter	Comment	Min	Typ	Max	Units
Package length		-	16.1	-	mm
Package width		-	7.6	-	mm
Pin pitch		-	1.27	-	mm
Co-planarity		-	-	0.1	mm
Stand-off		0.152		0.254	mm
Total package height		-	-	12.7	mm
Pin width		0.35	0.4	0.45	mm
Ferrule cavity depth		3.15	3.2	3.25	mm

Receiver ferrule diameter hole		3.13	3.15	3.17	mm
Transmitter ferrule diameter hole		3.53	3.55	3.57	mm
Hole pitch		-	6	-	mm
Package weight	Including clamping system		1.3	2	g
Ferrule Pressing force of each interface hole		1.5	-	8.5	N
Ferrule pull out force of each interface hole		4	-	15	N

### Package Drawing

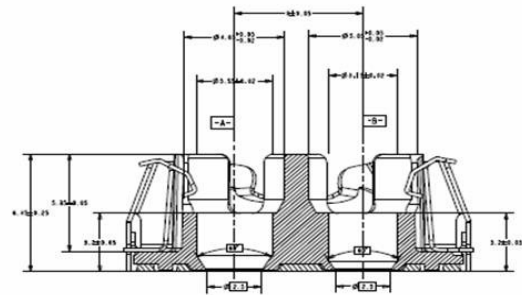
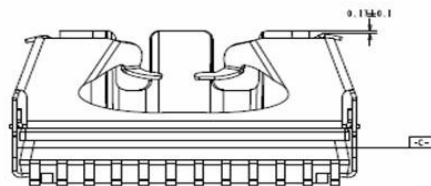
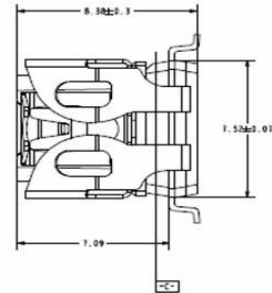
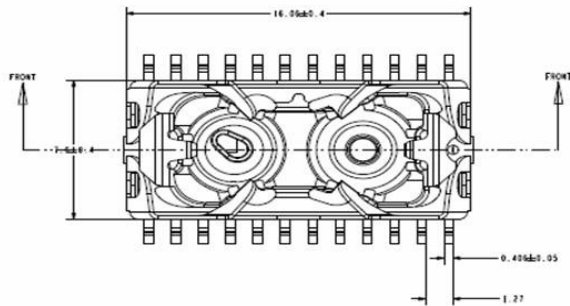

SECTION FRONT-FRONT  
Visible area above the plane C

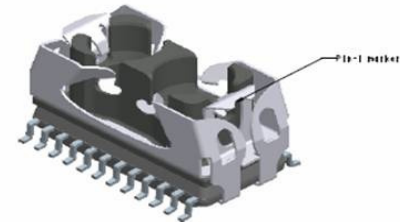

SCALE 3.000

Notes:  
 [1] Package according to JEDEC MS-013E [5] with following additional constraints and expansions:  
 - height not applicable  
 - coplanarity: < 0.1mm  
 - pin width:  $0.4 \pm 0.05$  mm ( [6] in MS-013E)  
 - stand-off: between 0.1mm and 0.3mm  
 - The Optical Reference Plane (ORP) is a plane parallel with the datum plane C and located at a distance  $0 \pm 0.1$ mm from datum plane C

MLX75608 SMD FOT		mm	
Part description	Quantity	Material	Dimensions
Designer	Date	Scale	<b>Melexis</b>
Carl Van Buggenhout	18-Feb-10	See drw	
		Projection	
Status:	Released	Project name:	MOST25 Rev.
Class:		Subassy name:	1.0
		ASSEM name:	MLX75608 sheet1/1

### Footprint

Foot print is based on standard SOIC 300mil package with 24 pins.  
Unit on the drawing: mm

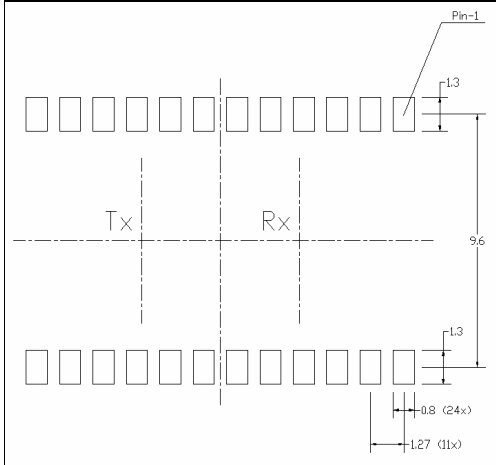

### Lead frame

A dedicated leadframe has been designed taking into account EMI consideration. Additionally to this, some die pad/fused pins are put in the middle allowing direct shielding inside component, enabling noise reduction and increased robustness against mechanical stress.

### Unique Features

- Temperature range: -40°C up to 95°C.
- Full automotive qualified package.
- Surface Mounting Device
- LED is trimmed during Melexis process to guarantee a maximum and stable optical output power.

### Recommended fiber ferrules

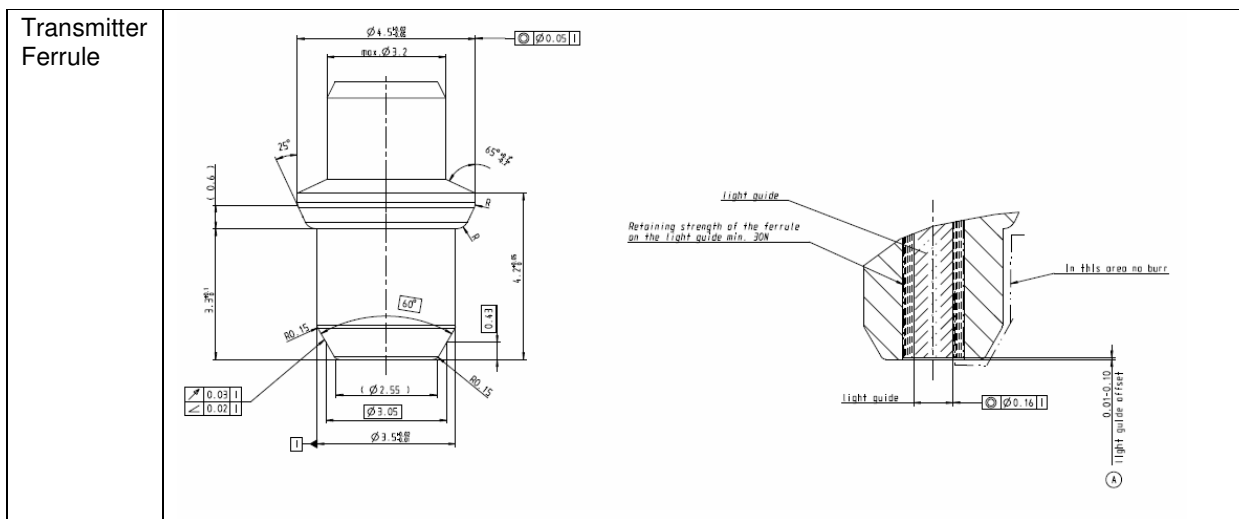

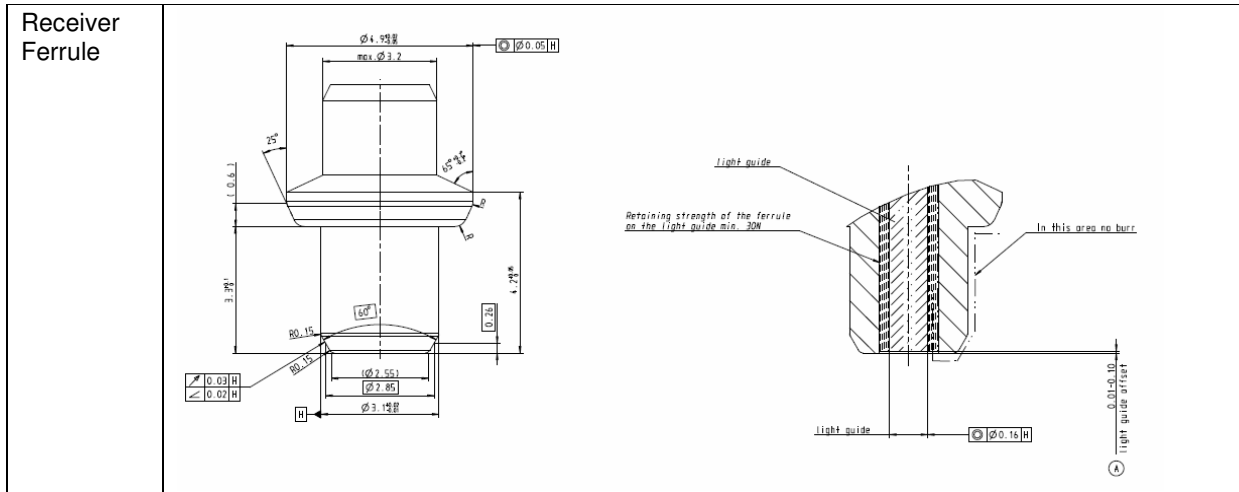

### Protection cap

A protection cap is placed before placing the device into the carrier tape. The cap allows better pick and place capability with a standard pick-up head. In addition, it increases immunity against possible contamination from the reflow oven. The material of the protection cap is able to withstand soldering reflow process. The protection cap can be removed easily, either manually or with a vacuum head. The protection cap can be plugged into the device in only one manner (poka yoke principle). A pin #1 marker can be found on top of the cap. In addition the metal clamp of the FOT also has a pin #1 marker. In following figure some drawings of the protection cap and the device in which it is plugged are shown with indication of both (cap and FOT) pin #1 markers.

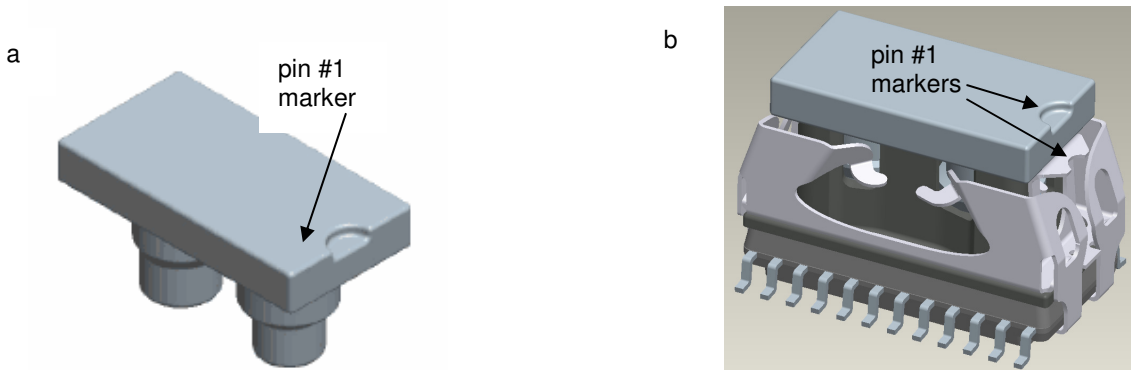

a) protection cap with “pin #1 marker” indicated

b) device with protection cap plugged in

The protection cap specifications are summarized in following table:

Parameter	Min	Typ	Max	Units
Pull-out force to remove protection cap.	0.8	1	1.5	N
Cap Length	12.9	13	13.1	mm
Cap Width	6.7	6.8	6.9	mm
Cap pin #1 marker radius	0.9	1	1.1	mm

### **Reliability Information**

Our products are classified and qualified regarding soldering technology, solderability and moisture sensitivity level according to following test methods:

Reflow Soldering SMD's

IPC/JEDEC J-STD-020

Moisture/Reflow Sensitivity Classification for Nonhermetic Solid State Surface Mount Devices

(classification reflow profiles according to table 5-2)

EIA/JEDEC JESD22-A113

Preconditioning of Non-hermetic Surface Mount Devices Prior to Reliability Testing

(reflow profiles according to table 2)

**IMPORTANT Note:** Wave Soldering for this type of SMD component isn't allowed, due to optical package opening.

EN60749-20

Resistance of plastic- encapsulated SMD's to combined effect of moisture and soldering heat

EIA/JEDEC JESD22-B106 and EN60749-15

Resistance to soldering temperature for through-hole mounted devices

Solderability

EIA/JEDEC JESD22-B102 and EN60749-21

For all soldering technologies deviating from above mentioned standard conditions (regarding peak temperature, temperature gradient, temperature profile etc) additional classification and qualification tests have to be agreed upon with Melexis.

The application of Wave Soldering for SMD's is allowed only after consulting Melexis regarding assurance of adhesive strength between device and board.

Melexis is contributing to global environmental conservation by promoting **lead free** solutions. For more information on qualifications of **RoHS** compliant products (RoHS = European directive on the Restriction Of the use of certain Hazardous Substances) please visit the quality page on our website:

<http://www.melexis.com/quality.asp>

**IMPORTANT:** In alignment with automotive standards, prior to production deliveries for automotive applications, a Part Submission Warrant need to be signed by the customer, in order to make sure that the is compatible with the applications. As the MLX75608 was developed for infotainment applications, use in safety-critical applications is at full responsibility of the customer.

### **Manufacturing Information**

#### **Soldering Process**

Product withstands Moisture Sensitivity Level #2a.

Product survives 260°C according IPC/JEDEC J-STD-020.

Besides to the JEDEC standard, the chip is able to withstand 245°C during 5 sec and 217°C during 60sec.

In order to protect device during soldering process, sample is delivered by Melexis with a protection on the top of the lid. This one can be easily removed before ferrule insertion. See also separate application note "MLX75605/MLX75608 Description of Packing".



# MLX75608

## 25Mbps Transmitter and Receiver for POF fiber

---

### ***Packing information***

See application note "MLX75605/MLX75608 Description of Packing" for details concerning packing (tube vs. reel), labeling, minimum order of quantity, etc.

### ***Precaution***

#### ***Optical opening precautions***

Only insertion of optical fiber terminated with a ferrule with dimensions as specified in the 25 Mbps MOST standard is allowed. Inserting anything else, e.g. an optical fiber not terminated with a standard MOST ferrule, can damage the part and will automatically lead to the loss of the Melexis Warranty.

#### ***ESD Precautions***

Electronic semiconductor products are sensitive to Electro Static Discharge (ESD). The product is qualified to reach 2kV Human Body Model. Always observe Electro Static Discharge control procedures whenever handling semiconductor products.

### ***Disclaimer***

Devices sold by Melexis are covered by the warranty and patent indemnification provisions appearing in its Term of Sale. Melexis makes no warranty, express, statutory, implied, or by description regarding the information set forth herein or regarding the freedom of the described devices from patent infringement. Melexis reserves the right to change specifications and prices at any time and without notice. Therefore, prior to designing this product into a system, it is necessary to check with Melexis for current information. This product is intended for use in normal commercial applications. Applications requiring extended temperature range, unusual environmental requirements, or high reliability applications, such as military, medical life-support or life-sustaining equipment are specifically not recommended without additional processing by Melexis for each application.

The information furnished by Melexis is believed to be correct and accurate. However, Melexis shall not be liable to recipient or any third party for any damages, including but not limited to personal injury, property damage, loss of profits, loss of use, interrupt of business or indirect, special incidental or consequential damages, of any kind, in connection with or arising out of the furnishing, performance or use of the technical data herein. No obligation or liability to recipient or any third party shall arise or flow out of Melexis' rendering of technical or other services.

© 2012 Melexis NV. All rights reserved.

For the latest version of this document, go to our website at  
[www.melexis.com](http://www.melexis.com)

Or for additional information contact Melexis Direct:

<b>Europe, Africa, Asia:</b>	<b>America:</b>
Phone: +32 1367 0495	Phone: +1 248 306 5400
E-mail: <a href="mailto:sales_europe@melexis.com">sales_europe@melexis.com</a>	E-mail: <a href="mailto:sales_usa@melexis.com">sales_usa@melexis.com</a>

ISO/TS 16949 and ISO14001 Certified