

Features

- **Cascadable 50 Ω Gain Block**
- **Low Operating Voltage (4.0 V typical V_d)**
- **3 dB Bandwidth: DC to 2.0 GHz**
- **12.5 dB typical Gain at 1.0 GHz**
- **Unconditionally Stable ($k > 1$)**
- **Surface Mount Plastic Package**
- **Tape-and-Reel Packaging Option Available¹**

Description

The MSA-0786 is a high performance silicon bipolar Monolithic Microwave Integrated Circuit (MMIC) housed in a low cost, surface mount plastic package. This MODAMP™ MMIC is designed for use as a general purpose 50 Ω gain block. Applications include narrow and broad band IF and RF amplifiers in commercial and industrial applications.

The MODAMP MSA-series is fabricated using a 10 GHz f_r , 25 GHz f_{max} silicon bipolar MMIC process which utilizes nitride self-alignment, ion implantation and gold metallization to achieve excellent uniformity, performance, and reliability. The use of an external bias resistor for temperature and current stability also allows bias flexibility.

86 Plastic Package

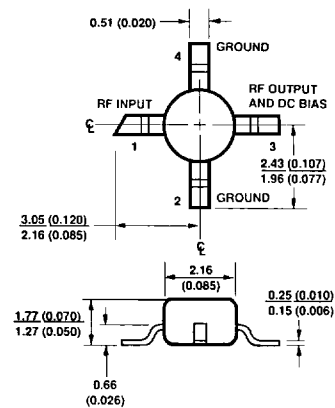

DIMENSIONS ARE IN MILLIMETERS (INCHES)

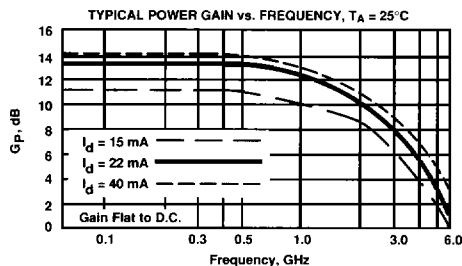

Typical Biasing Configuration

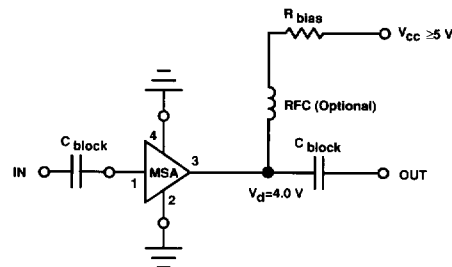

Electrical Specifications², $T_A = 25^\circ\text{C}$

Symbol	Parameters and Test Conditions: $I_d = 22\text{ mA}$, $Z_0 = 50\ \Omega$	Units	Min.	Typ.	Max.
GP	Power Gain ($ S_{21} ^2$) $f = 0.1\text{ GHz}$ $f = 1.0\text{ GHz}$	dB	10.5	13.5 12.5	
ΔGP	Gain Flatness $f = 0.1\text{ to }1.3\text{ GHz}$	dB		± 0.7	
$f_{3\text{ dB}}$	3 dB Bandwidth	GHz		2.0	
VSWR	Input VSWR $f = 0.1\text{ to }2.5\text{ GHz}$			1.7:1	
	Output VSWR $f = 0.1\text{ to }2.5\text{ GHz}$			1.7:1	
P_1 dB	Output Power @ 1 dB Gain Compression $f = 1.0\text{ GHz}$	dBm		5.5	
NF	50 Ω Noise Figure $f = 1.0\text{ GHz}$	dB		5.0	
IP ₃	Third Order Intercept Point $f = 1.0\text{ GHz}$	dBm		19.0	
t_D	Group Delay $f = 1.0\text{ GHz}$	psec.		150	
V_d	Device Voltage	V	3.2	4.0	4.8
dV/dT	Device Voltage Temperature Coefficient	mV/°C		-7.0	

Notes: 1. Refer to PACKAGING section "Tape-and-Reel Packaging for Semiconductor Devices."

2. The recommended operating current range for this device is 15 mA to 40 mA. Typical gain performance as a function of current is on the following page.

MSA-0786 MODAMP™ Cascadable Silicon Bipolar Monolithic Microwave Integrated Circuit Amplifiers

Absolute Maximum Ratings

Parameter	Absolute Maximum ¹
Device Current	60 mA
Power Dissipation ^{2,3}	275 mW
RF Input Power	+13 dBm
Junction Temperature	150°C
Storage Temperature	-65°C to 150°C

Thermal Resistance^{2,4}: $\theta_{jc} = 120^\circ\text{C/W}$

Notes:

1. Permanent damage may occur if any of these limits are exceeded.
2. T_{CASE} = 25°C
3. Derate at 8.3 mW/°C for T_C > 117°C.
4. See MEASUREMENTS section "Thermal Resistance" for more information.

Part Number Ordering Information

Part Number	Devices Per Reel	Reel Size
MSA-0786-TR1	1000	7"
MSA-0786-TR2	4000	13"

For more information, see "Tape and Reel Packaging for Semiconductor Devices", page 14-14.

Typical Performance, T_A = 25°C

(unless otherwise noted)

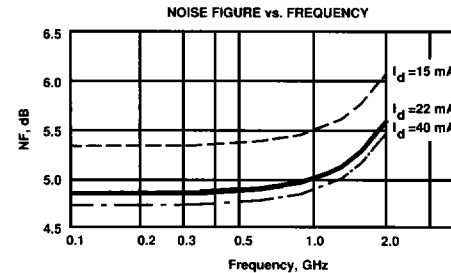
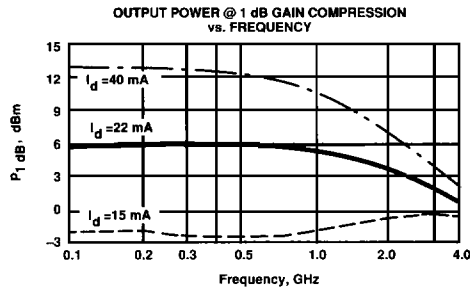
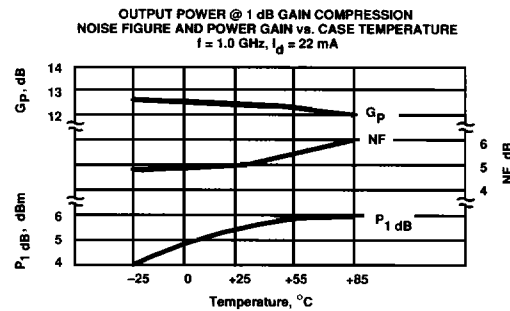
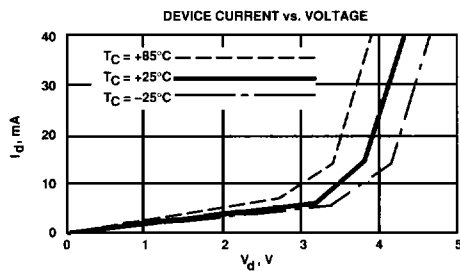

Typical Scattering Parameters: Z_O = 50 Ω

T_A = 25°C, I_d = 22 mA

Freq. GHz	S ₁₁		S ₂₁			S ₁₂			S ₂₂	
	Mag	Ang	dB	Mag	Ang	dB	Mag	Ang	Mag	Ang
0.1	.05	175	13.5	4.74	174	-18.7	.116	1	.14	-12
0.2	.05	174	13.4	4.71	169	-18.7	.117	3	.14	-22
0.4	.04	167	13.3	4.64	158	-18.4	.120	4	.15	-44
0.6	.04	175	13.1	4.52	148	-18.3	.122	7	.16	-65
0.8	.05	-156	12.9	4.39	138	-18.0	.126	8	.17	-84
1.0	.06	-134	12.6	4.25	127	-17.5	.134	10	.18	-102
1.5	.08	-142	11.6	3.79	103	-16.6	.148	9	.21	-139
2.0	.15	-159	10.5	3.34	80	-15.7	.164	7	.23	-164
2.5	.25	-176	9.2	2.89	63	-15.1	.176	5	.24	174
3.0	.33	166	7.8	2.45	44	-14.7	.185	1	.24	159
3.5	.41	150	6.5	2.11	27	-14.9	.179	-5	.24	149
4.0	.49	137	5.2	1.82	12	-15.1	.177	-9	.23	145
5.0	.60	116	3.0	1.41	-14	-15.4	.169	-14	.26	145

A model for this device is available in the DEVICE MODELS section.