

REVISIONS			
ISS	ZONE	DESCRIPTION \ PER REQUEST \ DATE	

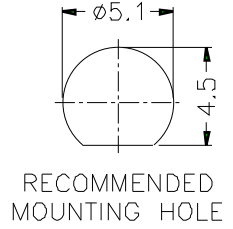
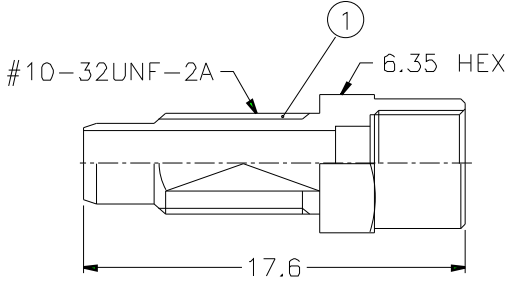
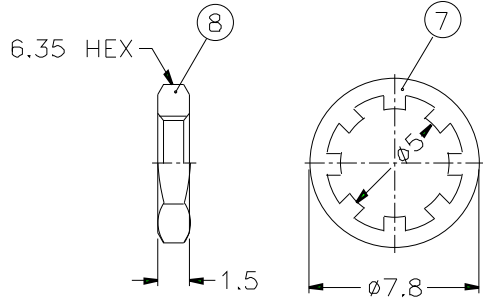

NOTES: FINISH (PLATING THICKNESS IN MICRO-INCHES)
 1. BRASS PER QQ-B-626
 2. BRASS PER QQ-B-613
 3. NICKEL PL. 100 MIN. THICK OVER COPPER STRIKE
 4. GOLD PL. 30 MIN. THICK OVER NICKEL PL. 100 MIN. THICK OVER COPPER STRIKE
 5. TEFLON MIL-P-19468
 6. JIS H 3250, C 2700

10	HEAT SHRINK TUBING			1	HT-56/5X193
9	FERRULE	NOTE 6	NOTE 3	1	FR-39/32X95
8	HEX NUT	NOTE 1	NOTE 3	1	HN635-10-32X15
7	LOCK WASHER	NOTE 2	NOTE 3	1	LW-78/5X05
6	HEX NUT	NOTE 1	NOTE 3	1	SMB5003-7-55/33
5	BARREL	NOTE 1	NOTE 3	1	SMB5003-6-27/17
4	INSULATOR	NOTE 5	NATURAL	1	SMB7003-4T-50
3	CONTACT PIN	NOTE 1	NOTE 4	1	SMB7403-3-15/Q6-B
2	INSULATOR	NOTE 5	NATURAL	1	SMB7403-2T-50-A
1	BODY	NOTE 1	NOTE 3	1	SMC1421G1-1
NO.	DESCRIPTION	MATERIAL	FINISH	Q'TY	DRAWING NO

SCALE	3/1	ISSUE	A	FILE NO.

PART NO.	SMC1421G1-NT30G-5-50
APPROVED	DATE 10-11-01'
CHECKED	DATE 10-11-01'
DRAWN	DATE 10-11-01'
TITLE	SMC BULKHEAD CRIMP JACK (FOR RG-174/U,188A/U,316/U)
DRAWING NO.	KJ-SMC1421G1-NT30G-316U-50
ITEM NO.	

Amphenol

1. CRIMPED FERRULE
 HEX CRIMP SIZE .128"
 2. CONTACT PIN TO SOLDER