

UP TO
 0.75 mm²
 WIRE SIZE

-	-	-
A	15.7	15.7
CODING	X	Y

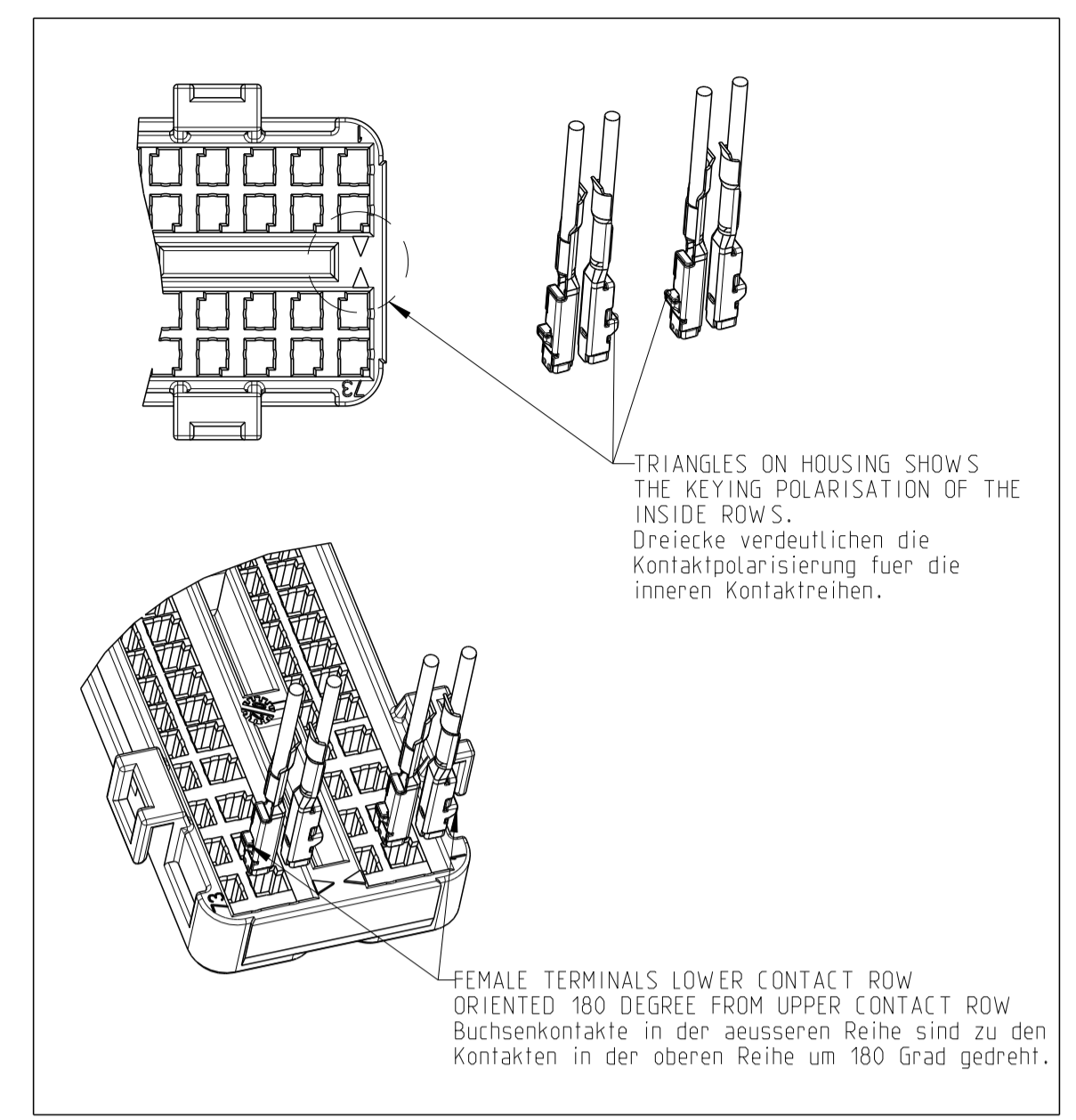

MARKING FOR PINOUT CONFIGURATION
 SEE TABLE SHEET 2
 Markierung fuer Pinoutkonfigkfiguration
 siehe Tabelle Blatt 2

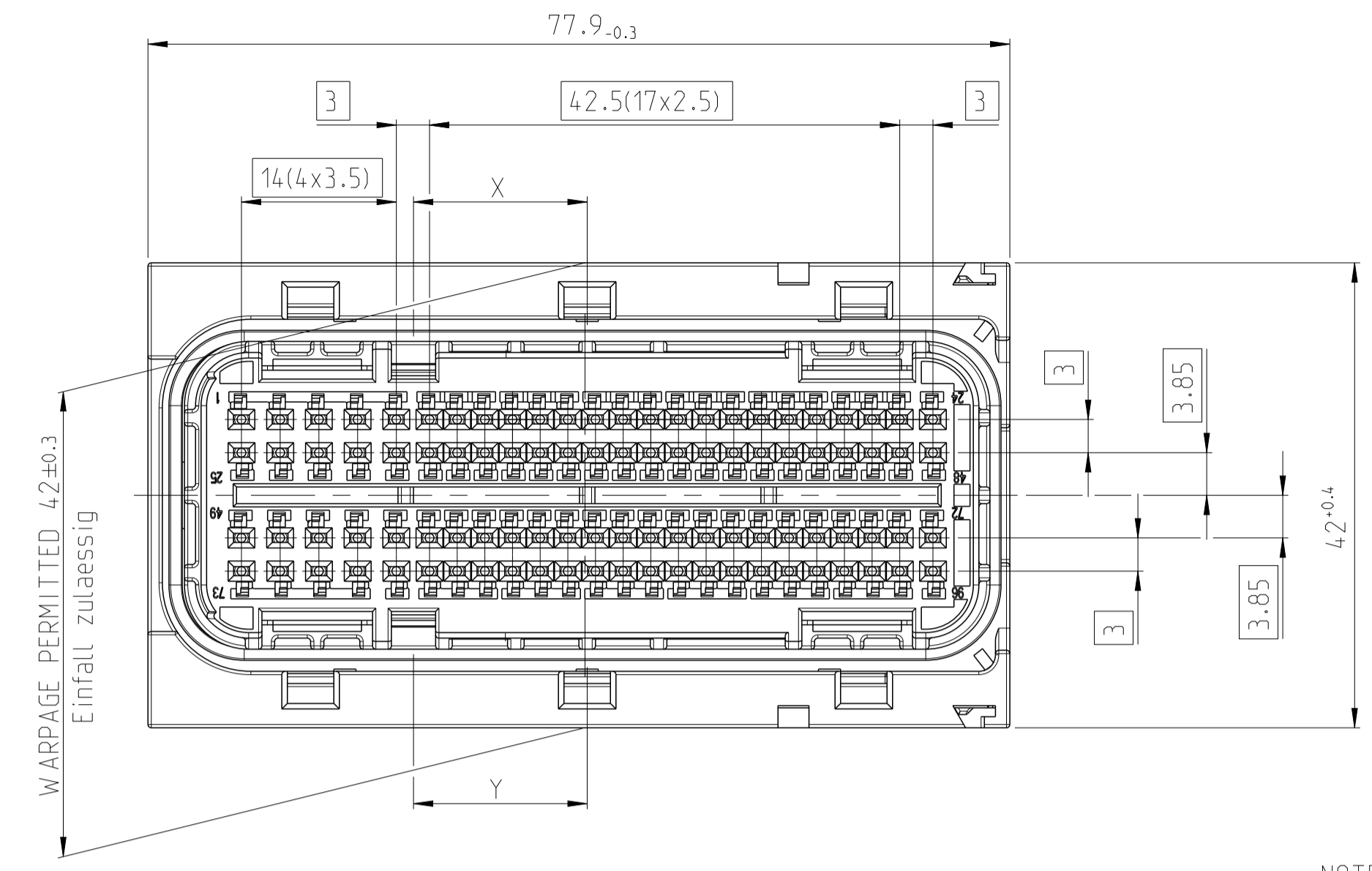
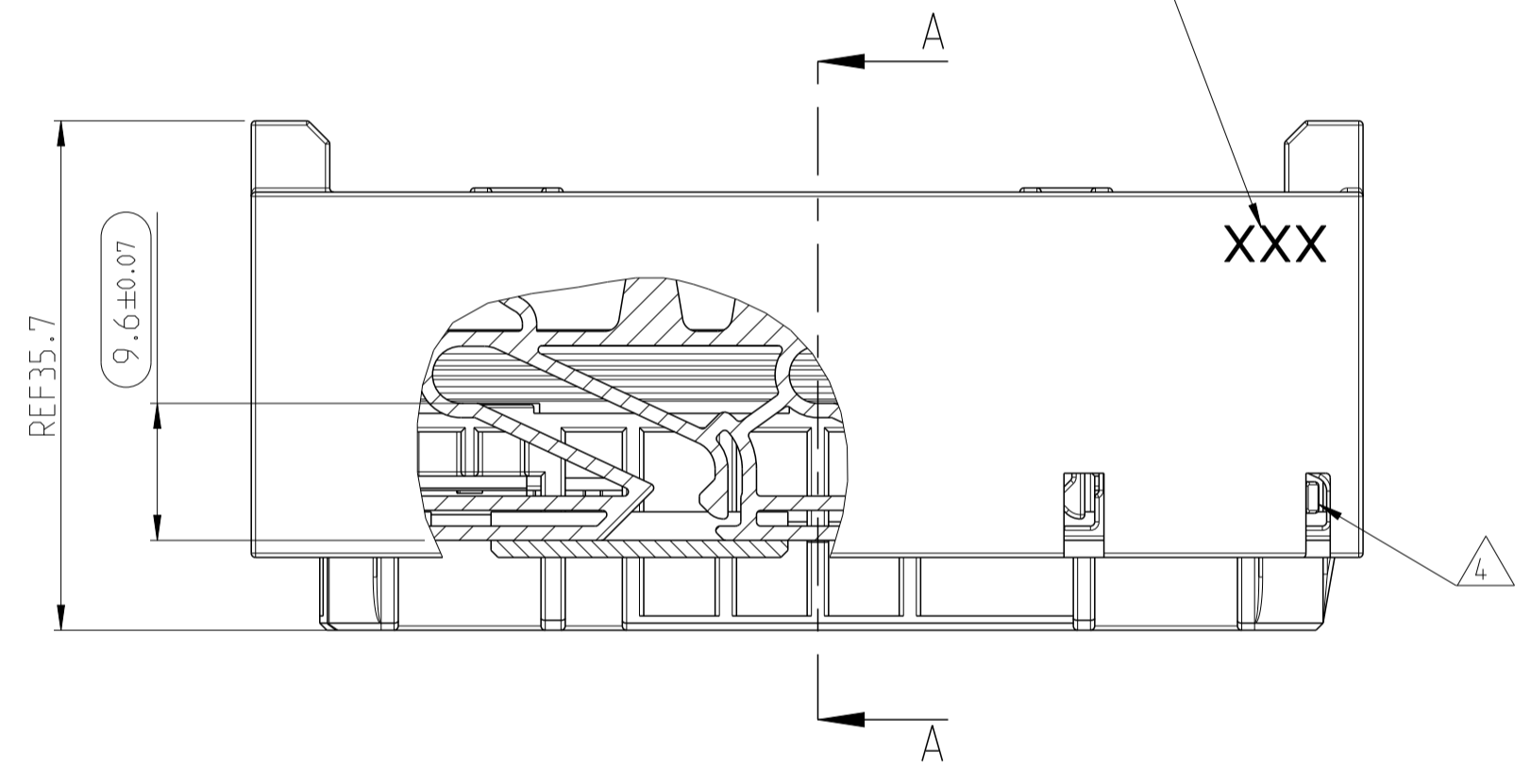
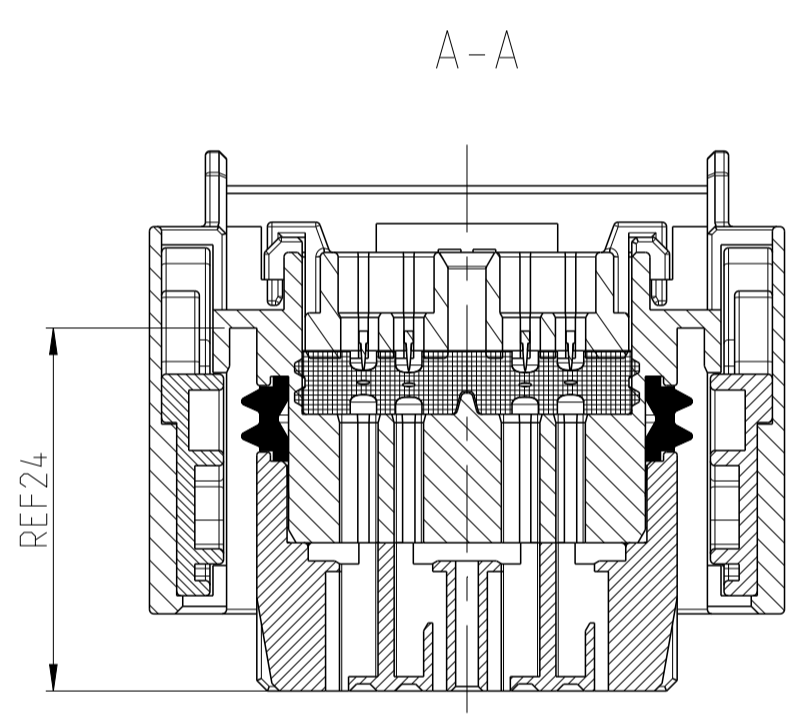

NOTES:
 Bemerkungen:

1 ASSY. USED WITH PARTS:
 Assy verwendet mit folgenden Teilen:
 HEADER BOSCH: PN: 000 20633 614
 HEADER TE: PN: 0-1565428-1

THE HEADER IS NOT A PART OF THE DELIVERED ASSY.
 Der Header ist kein Bestandteil der gelieferten ASSY.

2 MATED WITH:
 Passend zu:
 COVER PN: 1452389, 0-1452862-1
 2-NDARY LOCK PN: 0-1452388-1
 Kappe PN: 1452389, 0-1452862-1
 2te Kontaktsicherung PN: 0-1452388-1

3 SEALING FUNCTION REQUIRES ONLY FOLLOWING WIRE SIZE DIAMETERS FOR THE SIGNAL TERMINALS:
 Zur Sicherstellung der Dichtigkeit duerten folgende Drahtquerschnitte bei den Signalkontakten verwendet werden:

- a) 0.5mm² - 0.75mm² = ISO Ø1.4-1.9mm
 FOR ALL WITH "X" MARKED CAVITIES. SEE PINOUT CONFIGURATION TABLE fuer alle markierten Felder mit "X" in der Pinbelegungstabelle
- b) 1.0mm² - 1.5mm² = ISO Ø1.9-2.4mm
 FOR ALL WITH NUMBERED CAVITIES. SEE PINOUT CONFIGURATION TABLE fuer alle nummerierten Felder in der Pinbelegungstabelle

4 ASSY DELIVERED WITH SLIDES IN ENDOCK POSITION
 Anlieferungszustand Schieber in Endraststellung

5 TE-PN SHOWN AS "NOT USED" WERE RAISED FOR THE CONNECTOR TE-PN: X-1452419-X
 TE-Nr. mit "NOT USED" in der Pinbelegungstabelle werden verwendet im Stecker TE-Nr: X-1452419-X

6 TE-PN SHOWN AS "NOT USED" WERE RAISED FOR THE CONNECTOR TE-PN: X-1452423-X
 TE-Nr. mit "NOT USED" in der Pinbelegungstabelle werden verwendet im Stecker TE-Nr: X-1452423-X

INSPECTION DIMENSION
 Kontrollmasse

LOC	DIST	REVISIONS					
A1	-	P	LTH	DESCRIPTION	DATE	OWN	APVD
		L5		ECR-16-013617	23SEP2016	KC	SH
		L6		ECR-16-014434	12OCT2016	KC	SH
		L7		ECR-17-008199	15JUNE2017	KC	PT
		L8		ECR-20-009664	08JUL2020	VKS	PT

QTY	REQD PER ASSY	ASSY NO	MATERIAL	DESCRIPTION	COLOUR	ITEM NO
1x		PA66-GF25	96 POS. PCM CON. SLIDE RIGHT	BLACK	7	
1x		PA66-GF25	96 POS. PCM CON. SLIDE LEFT	BLACK	6	
1x		PBT-GF20	96 POS. PCM CON. COVER FOR FAMILY SEAL	BLACK	5	
1x		SILICONE	96 POS. PCM CON. FAMILY SEAL	WHITE	4	
1x		SILICONE	96 POS. PCM CON. PERIPHERAL SEAL	WHITE	3	
1x		PA66-GF35	96 POS. PCM CON. CONTACT HOUSING	BLACK	2	
1x		PA66-GF35	96 POS. PCM CON. FEMALE HOUSING	BLACK	1	
70		X-1452380-X	ASSY NO	DESCRIPTION	COLOUR	ITEM NO
				WEIGHT OF EACH ASSY NO (g)		
				PARTS LIST		

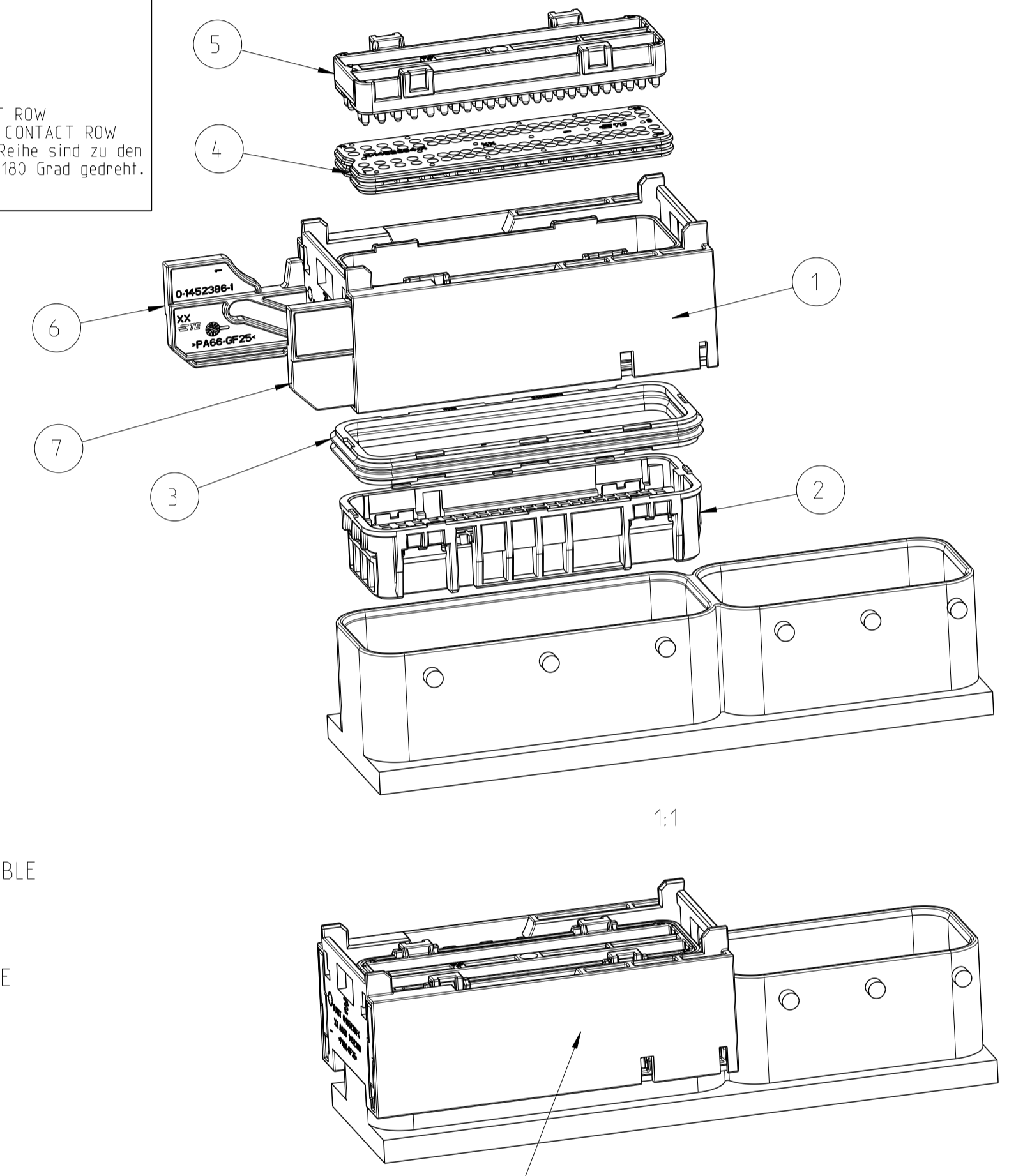

HOUSING IN ENDOCK POSITION
 WITHOUT COVER ASSY.
 Gehäuse in Endraststellung, ohne Kappenassy

* 1394897 WILL BE REPLACED DURING NEXT YEAR BY 1670144
 * 1394897 wird innerhalb eines Jahres ersetzt durch 1670144

TERMINALS TE PN	FINISH Oberflaeche	WIRE SIZE (mm ²) Drahtquerschnitt (mm ²)	NOTES Bemerkungen
0-1452503-3		1.0 - 1.5	
0-1670144-3 *	SILVER PLATED	0.5 - 0.75	
0-1534594-3		0.25 - 0.35	
0-1452503-2		1.0 - 1.5	
0-1670144-2 *	GOLD PLATED	0.5 - 0.75	
0-1534594-2		0.25 - 0.35	
0-1452503-1		1.0 - 1.5	
0-1670144-1 *	PRE-TIN	0.5 - 0.75	
0-1534594-1		0.25 - 0.35	

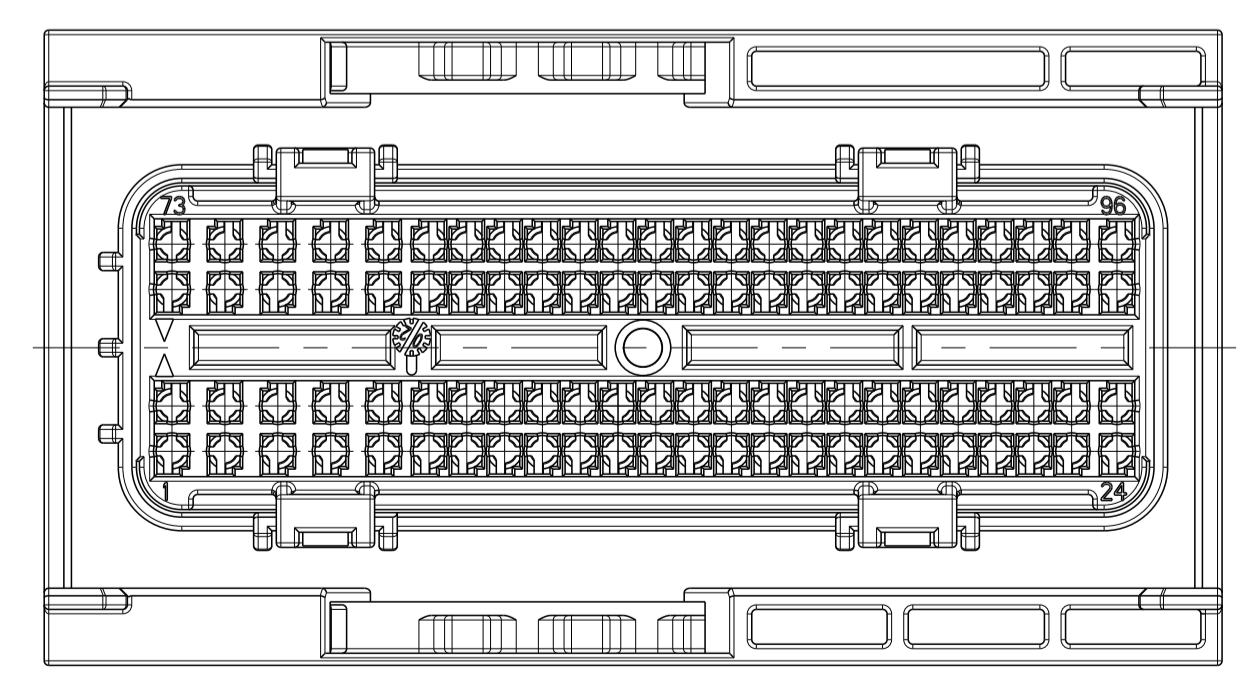

THIS DRAWING IS A CONTROLLED DOCUMENT.		OWN K.ROTH 12MAR2002	TE Connectivity	
DIMENSIONS: mm		CHK S.DENTER 12MAR2002		
TOLERANCES UNLESS OTHERWISE SPECIFIED:		APVD E. MUMMER 14MAR2002	NAME 96POS. RECEPTACLE HOUSING ASSEMBLY	
0 PLC # # # # 1 PLC # # # # 2 PLC # # # # 3 PLC # # # # 4 PLC # # # # ANGLES # # # #		APPLICATION SPEC 114-18534-1	SIZE CAGE CODE DRAWING NO RESTRICTED TO	
MATERIAL		WEIGHT	A1 00779 C=1452380	
		Customer Drawing	SCALE 2:1 SHEET 1 OF 3 REV. 18	

Mouser Electronics

Authorized Distributor

Click to View Pricing, Inventory, Delivery & Lifecycle Information:

[TE Connectivity:](#)

[9-1452380-9](#)