

## 5495A/DM7495 4-Bit Parallel Access Shift Registers

### General Description

These 4-bit registers feature parallel and serial inputs, parallel outputs, mode control, and two clock inputs. The registers have three modes of operation.

- Parallel (broadside) load
- Shift right (the direction  $Q_A$  toward  $Q_D$ )
- Shift left (the direction  $Q_D$  toward  $Q_A$ )

Parallel loading is accomplished by applying the four bits of data and taking the mode control input high. The data is loaded into the associated flip-flops and appears at the outputs after the high-to-low transition of the clock-2 input. During loading, the entry of serial data is inhibited.

Shift right is accomplished on the high-to-low transition of clock 1 when the mode control is low; shift left is accomplished on the high-to-low transition of clock 2 when the

mode control is high by connecting the output of each flip-flop to the parallel input of the previous flip-flop ( $Q_D$  to input C, etc.) and serial data is entered at input D. The clock input may be applied simultaneously to clock 1 and clock 2 if both modes can be clocked from the same source.

Changes at the mode control input should normally be made while both clock inputs are low; however, conditions described in the last three lines of the truth table will also ensure that register contents are protected.

### Features

- Typical maximum clock frequency 36 MHz
- Typical power dissipation 250 mW

### Connection Diagram

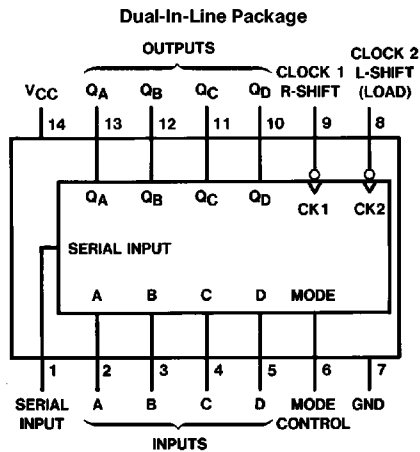

TL/F/6534-1

Order Number 5495ADMQB, 5495AFMQB or DM7495N  
See NS Package Number J14A, N14A or W14B

## Absolute Maximum Ratings (Note)

If Military/Aerospace specified devices are required, please contact the National Semiconductor Sales Office/Distributors for availability and specifications.

Supply Voltage	7V
Input Voltage	5.5V
Operating Free Air Temperature Range	
54A	–55°C to +125°C
DM74	0°C to +70°C
Storage Temperature Range	–65°C to +150°C

Note: The "Absolute Maximum Ratings" are those values beyond which the safety of the device cannot be guaranteed. The device should not be operated at these limits. The parametric values defined in the "Electrical Characteristics" table are not guaranteed at the absolute maximum ratings. The "Recommended Operating Conditions" table will define the conditions for actual device operation.

## Recommended Operating Conditions

Symbol	Parameter	5495A			DM7495			Units
		Min	Nom	Max	Min	Nom	Max	
V <sub>CC</sub>	Supply Voltage	4.5	5	5.5	4.75	5	5.25	V
V <sub>IH</sub>	High Level Input Voltage	2			2			V
V <sub>IL</sub>	Low Level Input Voltage			0.8			0.8	V
I <sub>OH</sub>	High Level Output Current			–0.8			–0.8	mA
I <sub>OL</sub>	Low Level Output Current			16			16	mA
f <sub>CLK</sub>	Clock Frequency (Note 4)	0		25	0		25	MHz
t <sub>W</sub>	Clock Pulse Width (Note 4)	15	11		15			ns
t <sub>SU</sub>	Data Setup Time (Note 4)	20	10		20	10		ns
t <sub>EN</sub>	Time to Enable Clock (Note 4)	Clock 1	20		20			ns
		Clock 2	15		15			
t <sub>H</sub>	Data Hold Time (Note 4)	0	–10		0	–10		ns
t <sub>IN</sub>	Time to Inhibit Clock 1 or Clock 2 (Note 4)	10			10			ns
T <sub>A</sub>	Free Air Operating Temperature	–55		125	0		70	°C

## Electrical Characteristics over recommended operating free air temperature range (unless otherwise noted)

Symbol	Parameter	Conditions	Min	Typ (Note 1)	Max	Units
V <sub>I</sub>	Input Clamp Voltage	V <sub>CC</sub> = Min, I <sub>I</sub> = –12 mA			–1.5	V
V <sub>OH</sub>	High Level Output Voltage	V <sub>CC</sub> = Min, I <sub>OH</sub> = Max V <sub>IL</sub> = Max, V <sub>IH</sub> = Min	2.4	3.4		V
V <sub>OL</sub>	Low Level Output Voltage	V <sub>CC</sub> = Min, I <sub>OL</sub> = Max V <sub>IH</sub> = Min, V <sub>IL</sub> = Max		0.2	0.4	V
I <sub>I</sub>	Input Current @ Max Input Voltage	V <sub>CC</sub> = Max, V <sub>I</sub> = 5.5V			1	mA
I <sub>IH</sub>	High Level Input Current	V <sub>CC</sub> = Max V <sub>I</sub> = 2.4V	Mode		80	μA
			Others		40	
I <sub>IL</sub>	Low Level Input Current	V <sub>CC</sub> = Max V <sub>I</sub> = 0.4V	Mode		–3.2	mA
			Others		–1.6	
I <sub>OS</sub>	Short Circuit Output Current	V <sub>CC</sub> = Max (Note 2)	DM54	–18	–57	mA
			DM74	–18	–57	
I <sub>CC</sub>	Supply Current	V <sub>CC</sub> = Max (Note 3)		50	75	mA

Note 1: All typicals are at V<sub>CC</sub> = 5V, T<sub>A</sub> = 25°C.

Note 2: Not more than one output should be shorted at a time.

Note 3: I<sub>CC</sub> is measured with all outputs and serial input open; A, B, C, and D inputs grounded; Mode Control at 4.5V; and a momentary 3V, then ground, applied to both clock inputs.

Note 4: T<sub>A</sub> = 25°C and V<sub>CC</sub> = 5V.

### Switching Characteristics at $V_{CC} = 5V$ and $T_A = 25^\circ C$ (See Section 1 for Test Waveforms and Output Load)

Symbol	Parameter	From (Input) To (Output)	$R_L = 400\Omega, C_L = 15\text{ pF}$		Units
			Min	Max	
$f_{MAX}$	Maximum Clock Frequency		25		MHz
$t_{PHL}$	Propagation Delay Time High to Low Level Output	Clock to Output		35	ns
$t_{PLH}$	Propagation Delay Time Low to High Level Output	Clock to Output		35	ns

### Function Table

Mode Control	Inputs				Outputs						
	Clocks		Serial	Parallel				$Q_A$	$Q_B$	$Q_C$	$Q_D$
	2(L)	1(R)		A	B	C	D				
H	H	X	X	X	X	X	X	$Q_{A0}$	$Q_{B0}$	$Q_{C0}$	$Q_{D0}$
H	↓	X	X	a	b	c	d	a	b	c	d
H	↓	X	X	$Q_{B\dagger}$	$Q_{C\dagger}$	$Q_{D\dagger}$	d	$Q_{Bn}$	$Q_{Cn}$	$Q_{Dn}$	d
L	L	H	X	X	X	X	X	$Q_{A0}$	$Q_{B0}$	$Q_{C0}$	$Q_{D0}$
L	X	↓	H	X	X	X	X	H	$Q_{An}$	$Q_{Bn}$	$Q_{Cn}$
L	X	↓	L	X	X	X	X	L	$Q_{An}$	$Q_{Bn}$	$Q_{Cn}$
↑	L	L	X	X	X	X	X	$Q_{A0}$	$Q_{B0}$	$Q_{C0}$	$Q_{D0}$
↓	L	L	X	X	X	X	X	$Q_{A0}$	$Q_{B0}$	$Q_{C0}$	$Q_{D0}$
↓	L	H	X	X	X	X	X	$Q_{A0}$	$Q_{B0}$	$Q_{C0}$	$Q_{D0}$
↑	H	L	X	X	X	X	X	$Q_{A0}$	$Q_{B0}$	$Q_{C0}$	$Q_{D0}$
↑	H	H	X	X	X	X	X	$Q_{A0}$	$Q_{B0}$	$Q_{C0}$	$Q_{D0}$

† Shifting left requires external connection of  $Q_B$  to A,  $Q_C$  to B,  $Q_D$  to C. Serial data is entered at input D.  
 H = High Level (Steady State), L = Low Level (Steady State), X = Don't Care (Any input, including transitions)  
 ↓ = Transition from high to low level, ↑ = Transition from low to high level  
 a, b, c, d = The level of steady, state input at inputs A, B, C, or D, respectively.  
 $Q_{A0}, Q_{B0}, Q_{C0}, Q_{D0}$  = The level of  $Q_A, Q_B, Q_C, Q_D$ , respectively, before the indicated steady state input conditions were established.  
 $Q_{An}, Q_{Bn}, Q_{Cn}, Q_{Dn}$  = The level of  $Q_A, Q_B, Q_C, Q_D$ , respectively, before the most recent ↓ transition of the clock.

### Logic Diagram

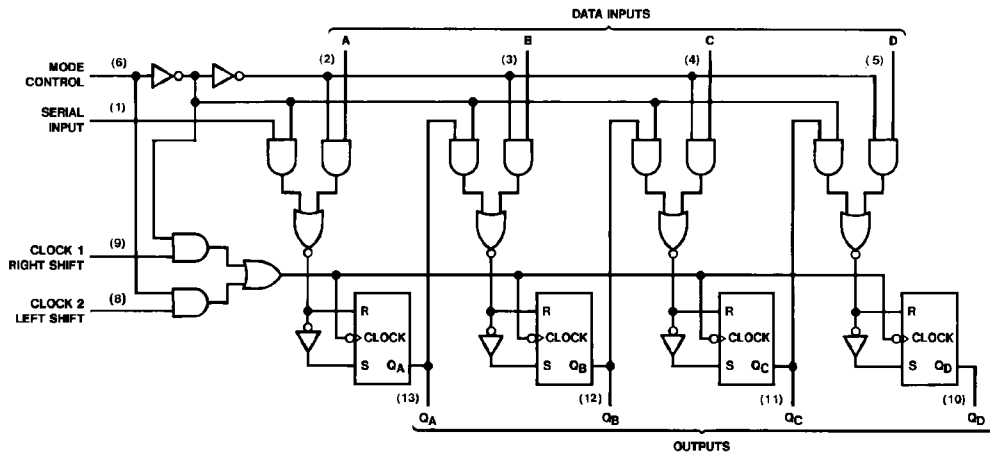

TL/F/6534-2

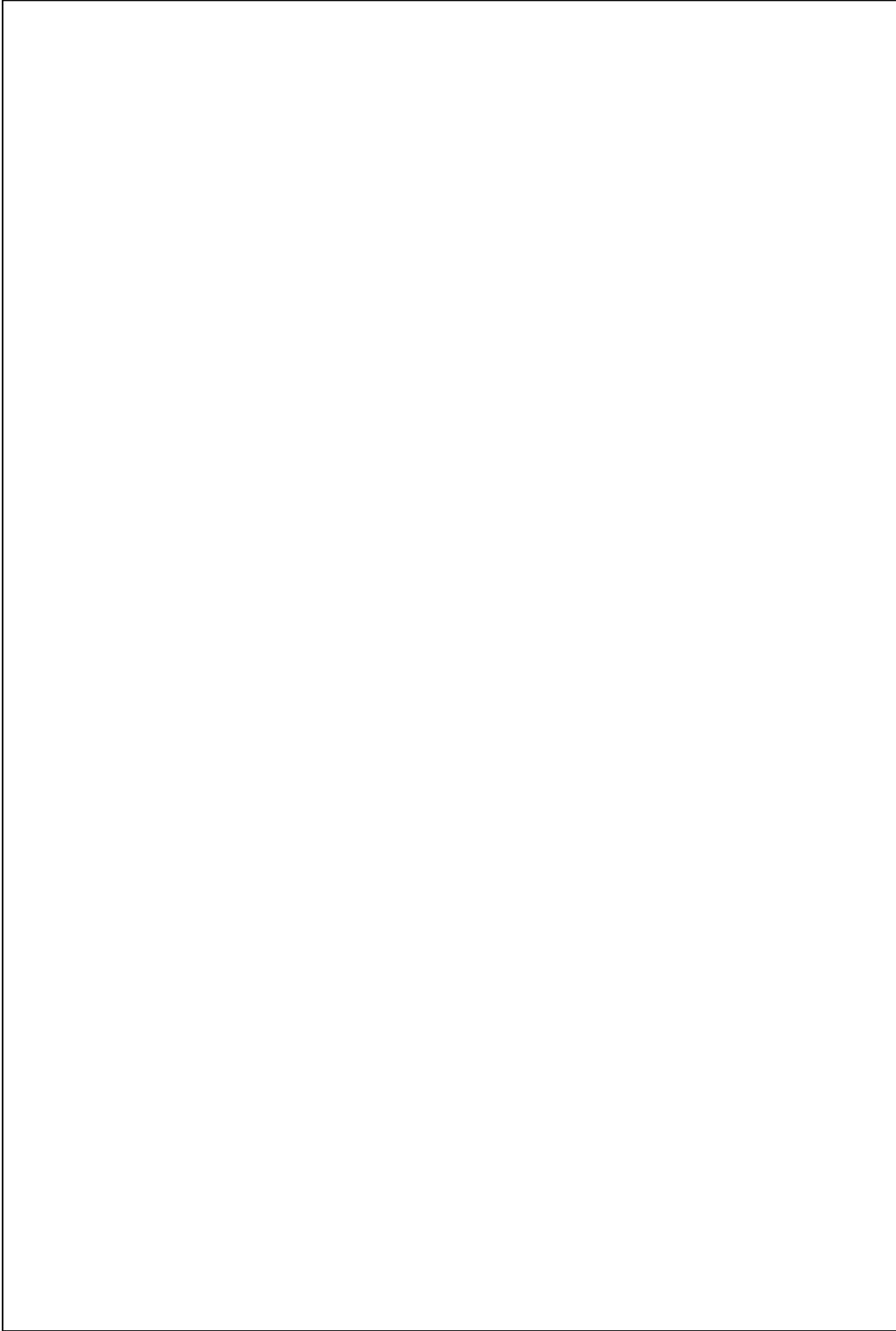

**Physical Dimensions** inches (millimeters)

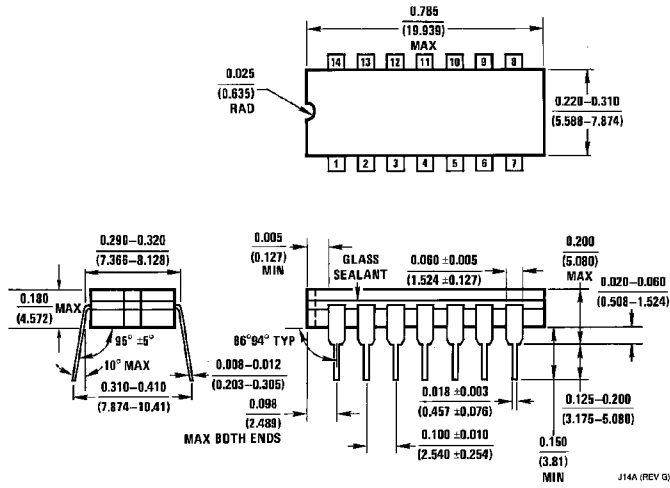

**14-Lead Ceramic Dual-In-Line Package (J)**  
**Order Number 5495ADMQB**  
**NS Package Number J14A**

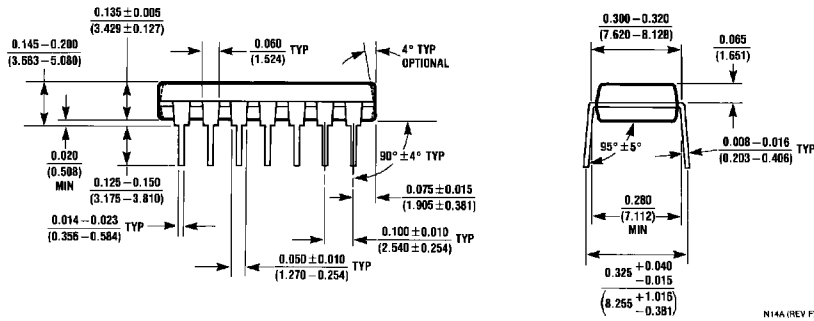
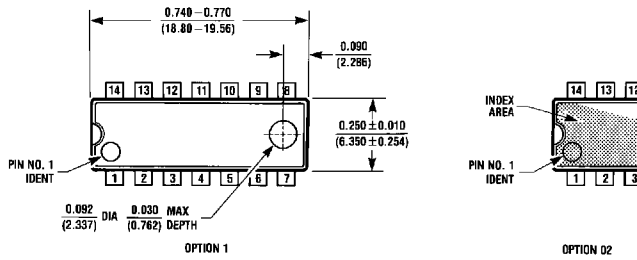

**14-Lead Molded Dual-In-Line Package (N)**  
**Order Number DM7495N**  
**NS Package Number N14A**

**Physical Dimensions** inches (millimeters)

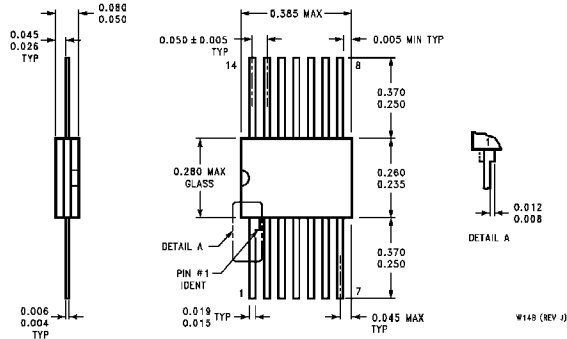

**14-Lead Ceramic Flat Package (W)**  
**Order Number 5495AFMQB**  
**NS Package Number W14B**

**LIFE SUPPORT POLICY**

NATIONAL'S PRODUCTS ARE NOT AUTHORIZED FOR USE AS CRITICAL COMPONENTS IN LIFE SUPPORT DEVICES OR SYSTEMS WITHOUT THE EXPRESS WRITTEN APPROVAL OF THE PRESIDENT OF NATIONAL SEMICONDUCTOR CORPORATION. As used herein:

1. Life support devices or systems are devices or systems which, (a) are intended for surgical implant into the body, or (b) support or sustain life, and whose failure to perform, when properly used in accordance with instructions for use provided in the labeling, can be reasonably expected to result in a significant injury to the user.
2. A critical component is any component of a life support device or system whose failure to perform can be reasonably expected to cause the failure of the life support device or system, or to affect its safety or effectiveness.



**National Semiconductor Corporation**  
 1111 West Bardin Road  
 Arlington, TX 76017  
 Tel: 1(800) 272-9959  
 Fax: 1(800) 737-7018

**National Semiconductor Europe**  
 Fax: (+49) 0-180-530 85 86  
 Email: [cnijwe@tevm2.nsc.com](mailto:cnijwe@tevm2.nsc.com)  
 Deutsch Tel: (+49) 0-180-530 85 85  
 English Tel: (+49) 0-180-532 78 32  
 Français Tel: (+49) 0-180-532 93 58  
 Italiano Tel: (+49) 0-180-534 16 80

**National Semiconductor Hong Kong Ltd.**  
 13th Floor, Straight Block,  
 Ocean Centre, 5 Canton Rd.  
 Tsimshatsui, Kowloon  
 Hong Kong  
 Tel: (852) 2737-1600  
 Fax: (852) 2736-9960

**National Semiconductor Japan Ltd.**  
 Tel: 81-043-299-2309  
 Fax: 81-043-299-2408

National does not assume any responsibility for use of any circuitry described, no circuit patent licenses are implied and National reserves the right at any time without notice to change said circuitry and specifications.