

0.5–10 GHz General Purpose Gallium Arsenide FET

Technical Data

ATF-25570

Features

- **High Output Power:**
20.5 dBm Typical $P_{1\text{ dB}}$ at 4 GHz
- **Low Noise Figure:**
1.0 dB Typical at 4 GHz
- **High Associated Gain:**
14.0 dB Typical at 4 GHz
- **Hermetic Gold-Ceramic
Microstrip Package**

Description

The ATF-25570 is a high performance gallium arsenide Schottky-barrier-gate field effect transistor housed in a hermetic, high reliabil-

ity package. This device is designed for use in general purpose amplifier and oscillator applications in the 0.5-10 GHz frequency range.

This GaAs FET device has a nominal 0.3 micron gate length using airbridge interconnects between drain fingers. Total gate periphery is 500 microns. Proven gold based metallization systems and nitride passivation assure a rugged, reliable device.

70 mil Package

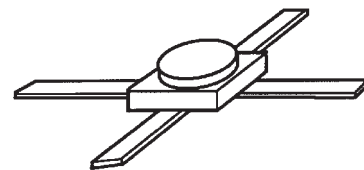

Electrical Specifications, $T_A = 25^\circ\text{C}$

Symbol	Parameters and Test Conditions	Units	Min.	Typ.	Max.
NF_O	Optimum Noise Figure: $V_{DS} = 3\text{ V}$, $I_{DS} = 20\text{ mA}$	f = 4.0 GHz f = 6.0 GHz f = 8.0 GHz	dB	1.0 1.2 1.4	1.3
G_A	Gain @ NF_O : $V_{DS} = 3\text{ V}$, $I_{DS} = 20\text{ mA}$	f = 4.0 GHz f = 6.0 GHz f = 8.0 GHz	dB	13.0 14.0 11.0 8.5	
$P_{1\text{ dB}}$	Power Output @ 1 dB Gain Compression: $V_{DS} = 5\text{ V}$, $I_{DS} = 50\text{ mA}$	f = 4.0 GHz	dBm	20.5	
$G_{1\text{ dB}}$	1 dB Compressed Gain: $V_{DS} = 5\text{ V}$, $I_{DS} = 50\text{ mA}$	f = 4.0 GHz	dB	13.0	
g_m	Transconductance: $V_{DS} = 3\text{ V}$, $V_{GS} = 0\text{ V}$		mmho	50	80
I_{DSS}	Saturated Drain Current: $V_{DS} = 3\text{ V}$, $V_{GS} = 0\text{ V}$		mA	50	100
V_P	Pinch-off Voltage: $V_{DS} = 3\text{ V}$, $I_{DS} = 1\text{ mA}$		V	-3.0	-2.0

ATF-25570 Absolute Maximum Ratings

Symbol	Parameter	Units	Absolute Maximum ^[1]
V_{DS}	Drain-Source Voltage	V	+7
V_{GS}	Gate-Source Voltage	V	-4
V_{GD}	Gate-Drain Voltage	V	-8
I_{DS}	Drain Current	mA	I_{DSS}
P_T	Power Dissipation ^[2,3]	mW	450
T_{CH}	Channel Temperature	°C	175
T_{STG}	Storage Temperature	°C	-65 to +175

Thermal Resistance: $\theta_{jc} = 300^\circ\text{C}/\text{W}$; $T_{CH} = 150^\circ\text{C}$
Liquid Crystal Measurement: $1\ \mu\text{m}$ Spot Size^[4]

Notes:

1. Permanent damage may occur if any of these limits are exceeded.
2. T_{CASE} TEMPERATURE = 25°C .
3. Derate at $3.3\ \text{mW}/^\circ\text{C}$ for $T_{CASE} > 40^\circ\text{C}$.
4. The small spot size of this technique results in a higher, though more accurate determination of θ_{jc} than do alternate methods. See MEASUREMENTS section for more information.

ATF-25570 Typical Performance, $T_A = 25^\circ\text{C}$

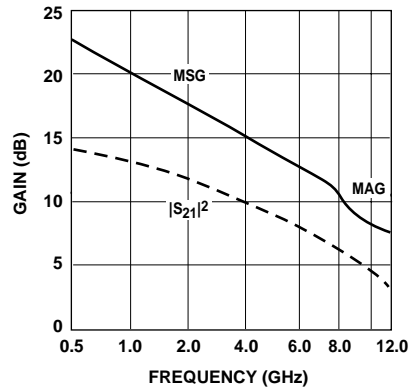

Figure 1. Insertion Power Gain, Maximum Available Gain and Maximum Stable Gain vs. Frequency. $V_{DS} = 3\ \text{V}$, $I_{DS} = 20\ \text{mA}$.

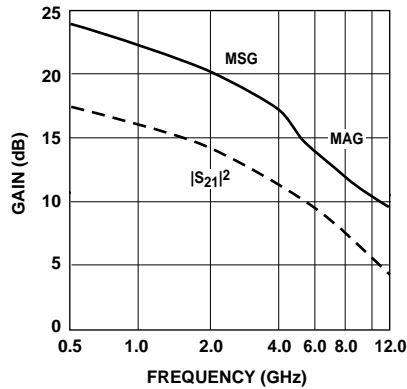

Figure 2. Insertion Power Gain, Maximum Available Gain and Maximum Stable Gain vs. Frequency. $V_{DS} = 5\ \text{V}$, $I_{DS} = 50\ \text{mA}$.

Typical Scattering Parameters, Common Emitter, $Z_O = 50 \Omega$, $T_A = 25^\circ\text{C}$, $V_{DS} = 3 \text{ V}$, $I_{DS} = 20 \text{ mA}$

Freq. GHz	S_{11}		S_{21}			S_{12}			S_{22}	
	Mag.	Ang.	dB	Mag.	Ang.	dB	Mag.	Ang.	Mag.	Ang.
0.5	.98	-24	14.0	5.02	160	-28.9	.036	71	.56	-24
1.0	.96	-41	13.4	4.70	145	-26.2	.049	62	.55	-33
2.0	.84	-76	12.3	4.14	115	-22.5	.075	44	.49	-51
3.0	.78	-100	10.8	3.48	94	-20.9	.090	33	.46	-60
4.0	.72	-123	9.6	3.01	73	-19.8	.102	20	.42	-76
5.0	.68	-142	8.5	2.67	54	-18.8	.114	9	.38	-88
6.0	.63	-162	7.8	2.45	36	-18.3	.121	0	.35	-101
7.0	.60	175	7.2	2.30	18	-17.5	.133	-7	.30	-118
8.0	.58	150	6.3	2.06	-1	-17.0	.141	-16	.26	-138
9.0	.59	128	5.6	1.90	-19	-16.7	.146	-28	.25	-167
10.0	.60	113	4.7	1.72	-36	-16.4	.151	-35	.26	172
11.0	.60	104	4.1	1.61	-48	-16.1	.157	-40	.28	155
12.0	.59	91	3.9	1.56	-68	-15.9	.160	-44	.30	146

Typical Scattering Parameters, Common Emitter, $Z_O = 50 \Omega$, $T_A = 25^\circ\text{C}$, $V_{DS} = 5 \text{ V}$, $I_{DS} = 50 \text{ mA}$

Freq. GHz	S_{11}		S_{21}			S_{12}			S_{22}	
	Mag.	Ang.	dB	Mag.	Ang.	dB	Mag.	Ang.	Mag.	Ang.
0.5	.97	-27	16.2	6.49	156	-32.0	.025	63	.59	-21
1.0	.94	-45	15.5	5.95	141	-29.9	.032	57	.60	-28
2.0	.81	-82	13.5	4.72	111	-26.2	.049	45	.58	-39
3.0	.73	-105	11.7	3.86	91	-24.9	.057	41	.55	-50
4.0	.66	-128	10.3	3.29	70	-23.4	.068	37	.52	-62
5.0	.61	-148	9.2	2.88	52	-22.5	.075	32	.49	-72
6.0	.57	-170	8.5	2.65	34	-21.6	.083	30	.48	-84
7.0	.56	167	7.6	2.41	16	-20.2	.097	28	.45	-98
8.0	.57	145	6.8	2.19	-1	-19.2	.110	18	.42	-115
9.0	.59	127	6.0	2.00	-18	-18.5	.119	12	.40	-136
10.0	.60	115	5.2	1.82	-35	-17.8	.129	4	.40	-159
11.0	.60	108	4.7	1.72	-47	-17.5	.134	1	.42	-176
12.0	.57	93	4.5	1.67	-64	-16.9	.143	-10	.44	173

A model for this device is available in the DEVICE MODELS section.

70 mil Package Dimensions

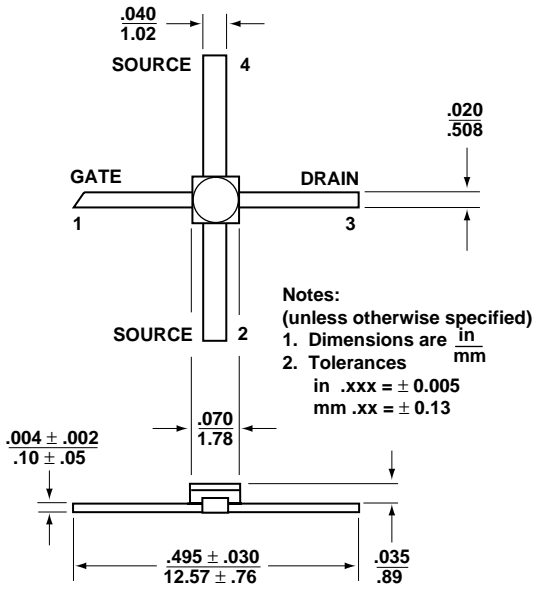

www.hp.com/go/rf

For technical assistance or the location of your nearest Hewlett-Packard sales office, distributor or representative call:

Americas/Canada: 1-800-235-0312 or 408-654-8675

Far East/Australasia: Call your local HP sales office.

Japan: (81 3) 3335-8152

Europe: Call your local HP sales office.

Data subject to change.
Copyright © 1998 Hewlett-Packard Co.

Obsoletes 5965-8711E
Printed in U.S.A. 5966-4977E (5/98)