



128K x 8 CMOS EPROM

Features

- CMOS for optimum speed/power
- High speed
  - $t_{AA} = 70$  ns max.
- Low power
  - 220 mW max.
  - Less than 85 mW when deselected
- Byte-wide memory organization
- 100% reprogrammable in the windowed package
- EPROM technology
- Capable of withstanding >2001V static discharge
- Available in
  - 32-pin PLCC
  - 32-pin TSOP-I
  - 32-pin, 600-mil plastic or hermetic DIP
  - 32-pin hermetic LCC

Functional Description

The CY27C010 is a high-performance, 1-megabit CMOS EPROM organized in 128 Kbytes. It is available in industry-standard 32-pin, 600-mil DIP, 32-pin LCC and PLCC, and 32-pin TSOP-I packages. The CY27C010 is available in windowed and opaque packages. Windowed packages allow the device to be erased with UV light for 100% reprogrammability.

The CY27C010 is equipped with a power-down chip enable ( $\overline{CE}$ ) input and output enable ( $\overline{OE}$ ). When  $\overline{CE}$  is deasserted, the device powers down to a low-power standby mode. The  $\overline{OE}$  pin three-states the outputs without putting the device into standby mode. While  $\overline{CE}$  offers lower power,  $\overline{OE}$  provides a more rapid transition to and from three-stated outputs.

The memory cells utilize proven EPROM floating-gate technology and byte-wide intelligent programming algorithms. The EPROM cell requires only 12.75 V for the supervoltage and low programming current allows for gang programming. The device allows for each memory location to be tested 100%, because each location is written to, erased, and repeatedly exercised prior to encapsulation. Each device is also tested for AC performance to guarantee that the product will meet DC and AC specification limits after customer programming.

The CY27C010 is read by asserting both the  $\overline{CE}$  and the  $\overline{OE}$  inputs. The contents of the memory location selected by the address on inputs  $A_{16} - A_0$  will appear at the outputs  $O_7 - O_0$ .

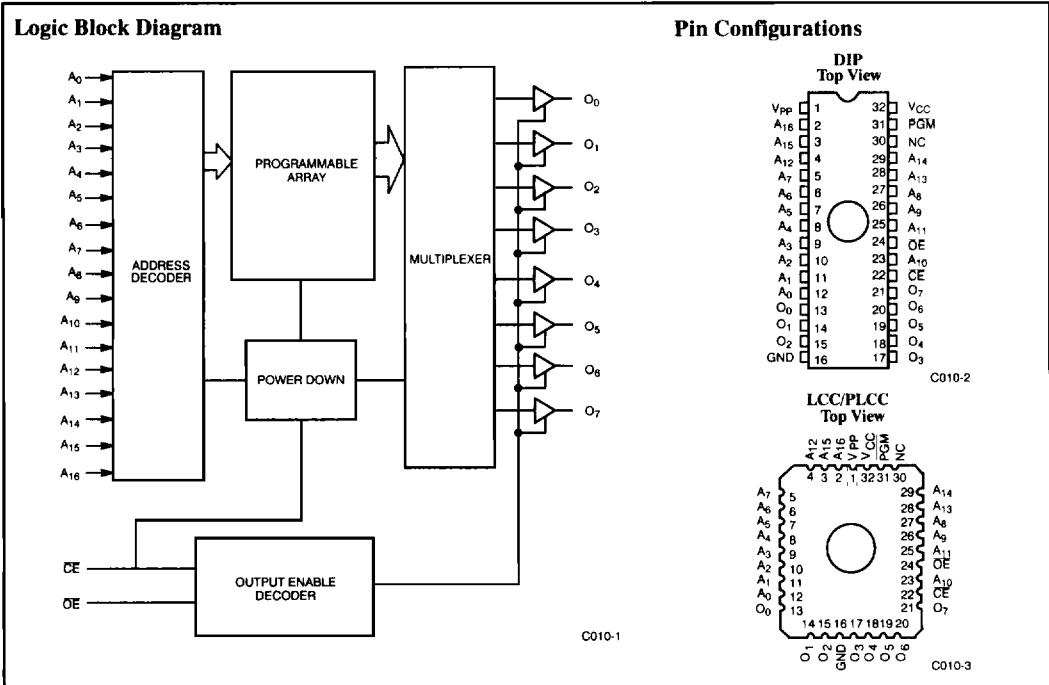

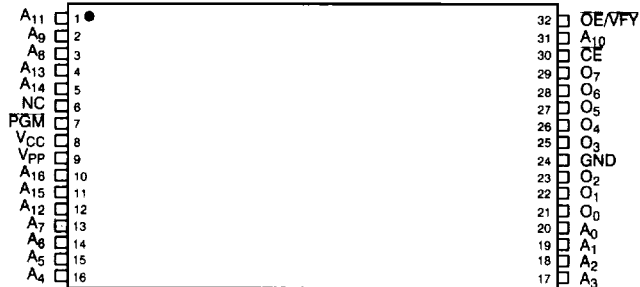
**Pin Configurations (continued)**
**TSOP  
Top View**

C010-4

**Selection Guide**

		27C010-70	27C010-90	27C010-120	27C010-150	27C010-200
Maximum Access Time (ns)		70	90	120	150	200
CE Access Time (ns)		70	90	120	150	200
OE Access Time (ns)		25	30	40	50	60
I <sub>CC</sub> <sup>[1]</sup> (mA) Power Supply Current	Com <sup>1</sup>	40	40	40	40	40
	Mil	50	50	50	50	50
I <sub>SB</sub> <sup>[2]</sup> (mA) Stand-by Current	Com <sup>1</sup>	15	15	15	15	15
	Mil	25	25	25	25	25

**Maximum Ratings**

(Above which the useful life may be impaired. For user guidelines, not tested.)

Storage Temperature	-65°C to +150°C
Ambient Temperature with Power Applied	-55°C to +125°C
Supply Voltage to Ground Potential	-0.5V to +7.0V
DC Voltage Applied to Outputs in High Z State	-0.5V to +5.5V
DC Input Voltage	-3.0V to +7.0V
Transient Input Voltage	-3.0V for <20 ns
DC Program Voltage	13.0V

**Notes:**

- V<sub>CC</sub> = Max., I<sub>OUT</sub> = 0 mA, f = 5 MHz.
- V<sub>CC</sub> = Max., CE = V<sub>II</sub>.

UV Erasure	7258 Wsec/cm <sup>2</sup>
Static Discharge Voltage (per MIL-STD-883, Method 3015)	> 2001V
Latch-Up Current	> 200 mA

**Operating Range**

Range	Ambient Temperature	V <sub>CC</sub>
Commercial	0°C to +70°C	5V ± 10%
Industrial <sup>[3]</sup>	-40°C to +85°C	5V ± 10%
Military <sup>[4]</sup>	-55°C to +125°C	5V ± 10%

- Contact a Cypress representative for industrial temperature range specification.
- T<sub>A</sub> is the "instant on" case temperature.

**Electrical Characteristics** Over the Operating Range<sup>[5, 6]</sup>

Parameter	Description	Test Conditions	27C010-70, 27C010-90, 27C010-120, 27C010-150, 27C010-200		Unit
			Min.	Max.	
V <sub>OH</sub>	Output HIGH Voltage	V <sub>CC</sub> = Min., I <sub>OH</sub> = -400 μA	2.4		V
V <sub>OL</sub>	Output LOW Voltage	V <sub>CC</sub> = Min., I <sub>OL</sub> = 2.1 mA		0.45	V
V <sub>IH</sub>	Input HIGH Level	Guaranteed Input Logical HIGH Voltage for All Inputs	2.0	V <sub>CC</sub> +0.5	V
V <sub>IL</sub>	Input LOW Level	Guaranteed Input Logical LOW Voltage for All Inputs		0.8	V
I <sub>IX</sub>	Input Leakage Current	GND ≤ V <sub>IN</sub> ≤ V <sub>CC</sub>	-10	+10	μA
I <sub>OZ</sub>	Output Leakage Current	GND ≤ V <sub>OUT</sub> ≤ V <sub>CC</sub> , Output Disable	-10	+10	μA
I <sub>CC</sub>	Power Supply Current	V <sub>CC</sub> = Max., I <sub>OUT</sub> = 0 mA, f = 5 MHz	Com'l	40	mA
			Mil	50	mA
I <sub>SB</sub>	Stand-By Current	V <sub>CC</sub> = Max., CE = V <sub>IH</sub>	Com'l	15	mA
			Mil	25	mA

**4**
**Capacitance<sup>[6]</sup>**

Parameter	Description	Test Conditions	Max.	Unit
C <sub>IN</sub>	Input Capacitance	T <sub>A</sub> = 25°C, f = 1 MHz, V <sub>CC</sub> = 5.0V	10	pF
C <sub>OUT</sub>	Output Capacitance		10	pF

**Notes:**

5. See the last page of this specification for Group A subgroup testing information.
6. See Introduction to CMOS NVMs in this Data Book for general information on testing.

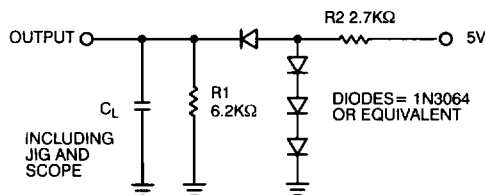
**AC Test Loads and Waveforms**

C<sub>L</sub> = 100 pF FOR -90, -120, -150, -200 DEVICES  
 C<sub>L</sub> = 30 pF FOR -70 DEVICES

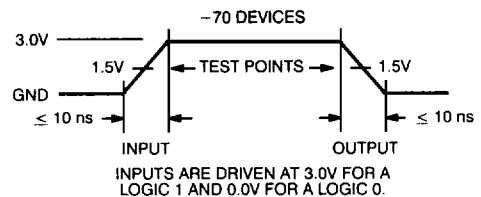
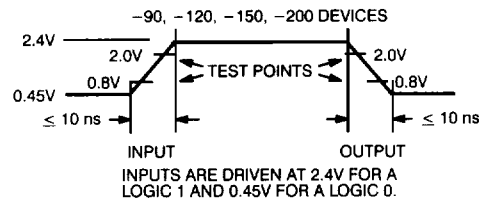

C010-5

C010-6

**Switching Characteristics** Over the Operating Range

Parameter	Description	27C010-70		27C010-90		27C010-120		27C010-150		27C010-200		Unit
		Min.	Max.	Min.	Max.	Min.	Max.	Min.	Max.	Min.	Max.	
$t_{AA}$	Address to Output Valid		70		90		120		150		200	ns
$t_{OE}$	$\overline{OE}$ Active to Output Valid		25		30		40		50		60	ns
$t_{HZOE}$	$\overline{OE}$ Inactive to High Z		25		30		40		50		60	ns
$t_{CE}$	$\overline{CE}$ Active to Output Valid		70		90		120		150		200	ns
$t_{HZCE}$	$\overline{CE}$ Inactive to High Z		25		30		30		30		30	ns
$t_{PU}$	$\overline{CE}$ Active to Power-Up	0		0		0		0		0		ns
$t_{PD}$	$\overline{CE}$ Inactive to Power-Down		60		65		65		65		65	ns
$t_{OH}$	Output Data Hold	0		0		0		0		0		ns

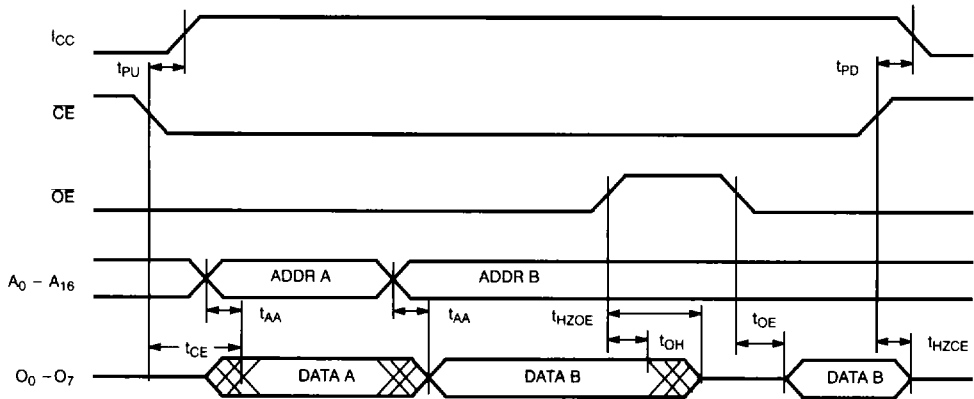
**Switching Waveform**

C010-7

**Erase Characteristics**

Wavelengths of light less than 4000 Angstroms begin to erase the CY27C010 in the windowed package. For this reason, an opaque label should be placed over the window if the EPROM is exposed to sunlight or fluorescent lighting for extended periods of time.

The recommended dose of ultraviolet light for erasure is a wavelength of 2537 Angstroms for a minimum dose (UV intensity multiplied by exposure time) of 25 Wsec/cm<sup>2</sup>. For an ultraviolet lamp with a 12 mW/cm<sup>2</sup> power rating, the exposure time would be approximately 35 minutes. The CY27C010 needs to be within 1 inch of the lamp during erasure. Permanent damage may result if the

EPROM is exposed to high-intensity UV light for an extended period of time. 7258 Wsec/cm<sup>2</sup> is the recommended maximum dosage.

**Programming Modes**

Programming support is available from Cypress as well as from a number of third-party software vendors. For detailed programming information, including a listing of software packages, please see the PROM Programming Information located at the end of this section. Programming algorithms can be obtained from any Cypress representative.

**Table 1. Programming Electrical Characteristics**

Parameter	Description	Min.	Max.	Unit
V <sub>PP</sub>	Programming Power Supply	12.5	13	V
I <sub>PP</sub>	Programming Supply Current		50	mA
V <sub>IHP</sub>	Programming Input Voltage HIGH	3.0	V <sub>CC</sub>	V
V <sub>ILP</sub>	Programming Input Voltage LOW	-0.5	0.4	V
V <sub>CCP</sub>	Programming V <sub>CC</sub>	6.0	6.5	V

**Table 2. Mode Selection**

Mode	Pin Function <sup>(7)</sup>						
	CE	OE	PGM	V <sub>PP</sub>	A <sub>0</sub>	A <sub>9</sub>	Data
Read	V <sub>IL</sub>	V <sub>IL</sub>	X	V <sub>IH</sub>	A <sub>0</sub>	A <sub>9</sub>	O <sub>7</sub> ~ O <sub>0</sub>
Output Disable	V <sub>IL</sub>	V <sub>IH</sub>	X	V <sub>IH</sub>	A <sub>0</sub>	A <sub>9</sub>	High Z
Stand-by	V <sub>IH</sub>	X	X	V <sub>IH</sub>	X	X	High Z
Program	V <sub>ILP</sub>	V <sub>IHP</sub>	V <sub>ILP</sub>	V <sub>PP</sub>	A <sub>0</sub>	A <sub>9</sub>	D <sub>7</sub> ~ D <sub>0</sub>
Program Verify	V <sub>ILP</sub>	V <sub>ILP</sub>	V <sub>IHP</sub>	V <sub>PP</sub>	A <sub>0</sub>	A <sub>9</sub>	O <sub>7</sub> ~ O <sub>0</sub>
Program Inhibit	V <sub>ILP</sub>	V <sub>IHP</sub>	V <sub>IHP</sub>	V <sub>PP</sub>	A <sub>0</sub>	A <sub>9</sub>	High Z
Signature Read (MFG)	V <sub>IL</sub>	V <sub>IL</sub>	X	V <sub>IH</sub>	V <sub>IL</sub>	V <sub>HV</sub> <sup>[8]</sup>	34H
Signature Read (DEV)	V <sub>IL</sub>	V <sub>IL</sub>	X	V <sub>IH</sub>	V <sub>IH</sub>	V <sub>HV</sub> <sup>[8]</sup>	1DH <sup>[9]</sup>

Note:

7. X can be V<sub>IL</sub> or V<sub>IH</sub>.

8. V<sub>HV</sub> = 12V ± 0.5V

9. Subject to change before final version.



Ordering Information<sup>[10]</sup>

Speed (ns)	Ordering Code	Package Name	Package Type	Operating Range
70	CY27C010-70JC	J65	32-Lead Plastic Leaded Chip Carrier	Commercial
	CY27C010-70PC	P15	32-Lead (600-Mil) Molded DIP	
	CY27C010-70WC	W20	32-Lead (600-Mil) Windowed CerDIP	
	CY27C010-70ZC	Z32	32-Lead Thin Small Outline Package	
	CY27C010-70DMB	D20	32-Lead (600-Mil) CerDIP	Military
	CY27C010-70LMB	L55	32-Pin Rectangular Leadless Chip Carrier	
	CY27C010-70QMB	Q55	32-Pin Windowed Rectangular Leadless Chip Carrier	
CY27C010-70WMB	W20	32-Lead (600-Mil) Windowed CerDIP		
90	CY27C010-90JC	J65	32-Lead Plastic Leaded Chip Carrier	Commercial
	CY27C010-90PC	P19	32-Lead (600-Mil) Molded DIP	
	CY27C010-90WC	W20	32-Lead (600-Mil) Windowed CerDIP	
	CY27C010-90ZC	Z32	32-Lead Thin Small Outline Package	
	CY27C010-90DMB	D20	32-Lead (600-Mil) CerDIP	Military
	CY27C010-90LMB	L55	32-Pin Rectangular Leadless Chip Carrier	
	CY27C010-90QMB	Q55	32-Pin Windowed Rectangular Leadless Chip Carrier	
CY27C010-90WMB	W20	32-Lead (600-Mil) Windowed CerDIP		
120	CY27C010-120JC	J65	32-Lead Plastic Leaded Chip Carrier	Commercial
	CY27C010-120PC	P19	32-Lead (600-Mil) Molded DIP	
	CY27C010-120WC	W20	32-Lead (600-Mil) Windowed CerDIP	
	CY27C010-120ZC	Z32	32-Lead Thin Small Outline Package	
	CY27C010-120DMB	D20	32-Lead (600-Mil) CerDIP	Military
	CY27C010-120LMB	L55	32-Pin Rectangular Leadless Chip Carrier	
	CY27C010-120QMB	Q55	32-Pin Windowed Rectangular Leadless Chip Carrier	
CY27C010-120WMB	W20	32-Lead (600-Mil) Windowed CerDIP		
150	CY27C010-150JC	J65	32-Lead Plastic Leaded Chip Carrier	Commercial
	CY27C010-150PC	P19	32-Lead (600-Mil) Molded DIP	
	CY27C010-150WC	W20	32-Lead (600-Mil) Windowed CerDIP	
	CY27C010-150ZC	Z32	32-Lead Thin Small Outline Package	
	CY27C010-150DMB	D20	32-Lead (600-Mil) CerDIP	Military
	CY27C010-150LMB	L55	32-Pin Rectangular Leadless Chip Carrier	
	CY27C010-150QMB	Q55	32-Pin Windowed Rectangular Leadless Chip Carrier	
CY27C010-150WMB	W20	32-Lead (600-Mil) Windowed CerDIP		
200	CY27C010-200JC	J65	32-Lead Plastic Leaded Chip Carrier	Commercial
	CY27C010-200PC	P19	32-Lead (600-Mil) Molded DIP	
	CY27C010-200WC	W20	32-Lead (600-Mil) Windowed CerDIP	
	CY27C010-200ZC	Z32	32-Lead Thin Small Outline Package	
	CY27C010-200DMB	D20	32-Lead (600-Mil) CerDIP	Military
	CY27C010-200LMB	L55	32-Pin Rectangular Leadless Chip Carrier	
	CY27C010-200QMB	Q55	32-Pin Windowed Rectangular Leadless Chip Carrier	
CY27C010-200WMB	W20	32-Lead (600-Mil) Windowed CerDIP		

Notes:

10. Most of the above products are available in industrial temperature range. Contact a Cypress representative for specifications and product availability.



**MILITARY SPECIFICATIONS**  
**Group A Subgroup Testing**

**DC Characteristics**

Parameter	Subgroups
V <sub>OH</sub>	1, 2, 3
V <sub>OL</sub>	1, 2, 3
V <sub>IH</sub>	1, 2, 3
V <sub>IL</sub>	1, 2, 3
I <sub>Ix</sub>	1, 2, 3
I <sub>OZ</sub>	1, 2, 3
I <sub>CC</sub>	1, 2, 3
I <sub>SB</sub>	1, 2, 3

**Switching Characteristics**

Parameter	Subgroups
t <sub>AA</sub>	7, 8, 9, 10, 11
t <sub>OE</sub>	7, 8, 9, 10, 11
t <sub>CE</sub>	7, 8, 9, 10, 11

Document #: 38-00428