

GLASS PASSIVATED BRIDGE RECTIFIERS

REVERSE VOLTAGE - 50 to 1000 Volts
FORWARD CURRENT - 1.0 Amperes

FEATURES

- Rating to 1000V PRV
- Ideal for printed circuit board
- Low forward voltage drop, high current capability.
- Reliable low cost construction utilizing molded plastic technique results in inexpensive product
- Lead Pb/Sn copper
- The plastic material has UL flammability classification 94V-0

MECHANICAL DATA

- Polarity : As marked on Body
- Weight : 0.02 ounces, 0.38 grams
- Mounting position : Any

DB-1

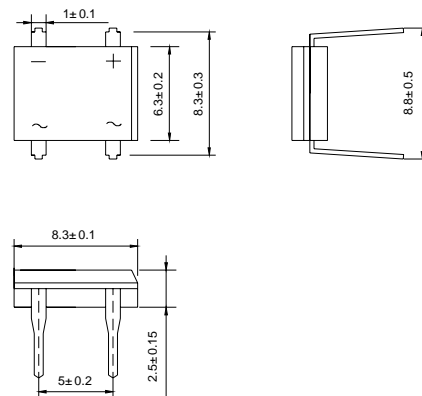

Dimensions in millimeters

MAXIMUM RATINGS AND ELECTRICAL CHARACTERISTICS

Ratings at 25°C ambient temperature unless otherwise specified.
Single phase, half wave, 60Hz, resistive or inductive load.
For capacitive load, derate current by 20%

CHARACTERISTICS	SYMBOL	DF005M	DF01M	DF02M	DF04M	DF06M	DF08M	DF10M	UNIT
Maximum Recurrent Peak Reverse Voltage	V _{RRM}	50	100	200	400	600	800	1000	V
Maximum RMS Voltage	V _{RMS}	35	70	140	280	420	560	700	V
Maximum DC Blocking Voltage	V _{DC}	50	100	200	400	600	800	1000	V
Maximum Average Forward Rectified Current @T _A =40°C	I _(AV)	1.0							A
Peak Forward Surge Current 8.3ms single half sine-wave superimposed on rated load (JEDEC METHOD)	I _{FSM}	50							A
Maximum forward Voltage at 1.0A DC	V _F	1.1							V
Maximum DC Reverse Current at Rated DC Blocking Voltage @T _J =25°C @T _J =125°C	I _R	10 500							uA
I ² t Rating for fusing (t < 8.3ms)	I ² t	10.4							A ² S
Typical Junction Capacitance per element (Note 1)	C _J	25							pF
Typical Thermal Resistance (Note 2)	R _{θJA}	40							°C/W
Operating Temperature Range	T _J	-55 to +150							°C
Storage Temperature Range	T _{STG}	-55 to +150							°C

NOTES : 1. Measured at 1.0MHz and applied reverse voltage of 4.0V DC.
2. Thermal resistance from junction to ambient mounted on P.C.B with 0.5x0.5" (13x13mm) copper pads.

www.galaxycn.com

