

PART NO.	DIM "A"	FIGURE
515-1304-0100F	0.100 (2.5mm)	1
515-1304-0125F	0.125 (3.2mm)	
515-1304-0188F	0.188 (4.8mm)	
515-1304-0250F	0.250 (6.4mm)	
515-1304-0313F	0.313 (7.9mm)	
515-1304-0350F	0.350 (8.9mm)	
515-1304-0375F	0.375 (9.5mm)	
515-1304-0500F	0.500 (12.7mm)	
515-1304-0625F	0.625 (15.9mm)	
515-1304-0750F	0.750 (19.0mm)	
515-1304-0830F	0.830 (21.1mm)	
515-1304-1000F	1.000 (25.4mm)	2
515-1305-0125F	0.125 (3.2mm)	
515-1305-0250F	0.250 (6.4mm)	
515-1305-0350F	0.350 (8.9mm)	
515-1305-0375F	0.375 (9.5mm)	
515-1305-0460F	0.460 (11.7mm)	
515-1305-0500F	0.500 (12.7mm)	
515-1305-0625F	0.625 (15.9mm)	
515-1305-0750F	0.750 (19.0mm)	
515-1305-1000F	1.000 (25.4mm)	
515-1306-0125F	0.125 (3.2mm)	3
515-1306-0250F	0.250 (6.4mm)	
515-1306-0350F	0.350 (8.9mm)	
515-1306-0375F	0.375 (9.5mm)	
515-1306-0460F	0.460 (11.7mm)	
515-1306-0500F	0.500 (12.7mm)	
515-1306-0625F	0.625 (15.9mm)	
515-1306-0750F	0.750 (19.0mm)	
515-1306-1000F	1.000 (25.4mm)	

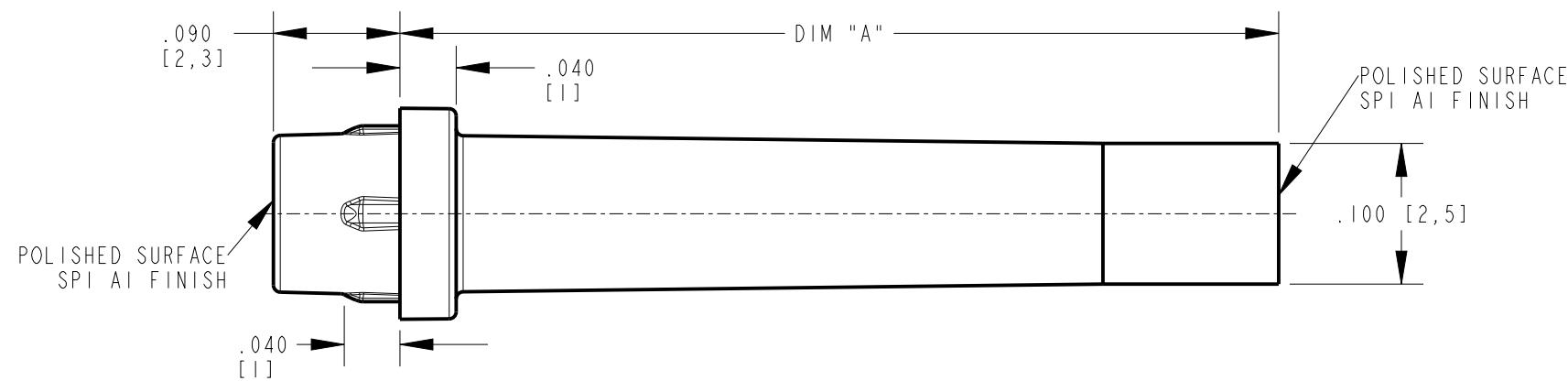
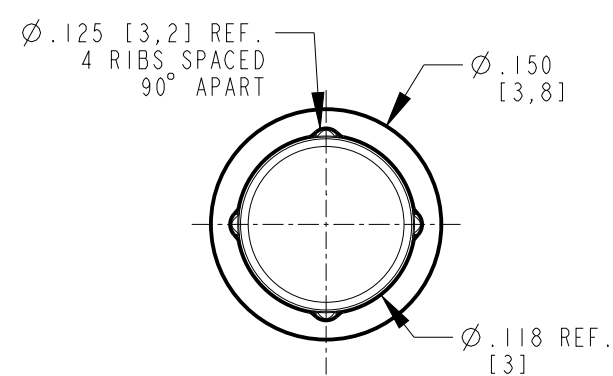

FIGURE 1

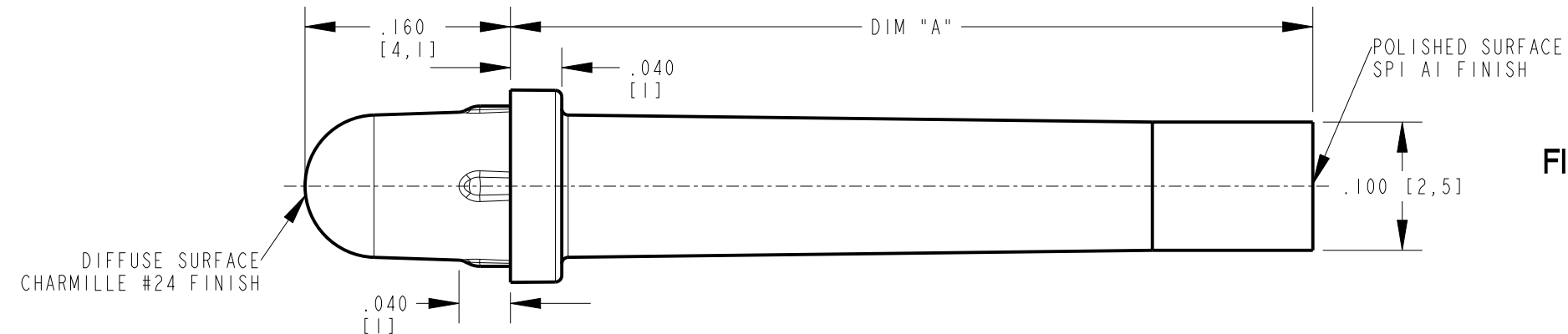
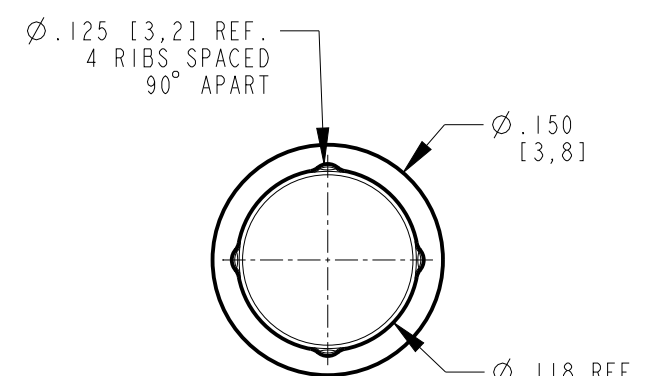

FIGURE 2

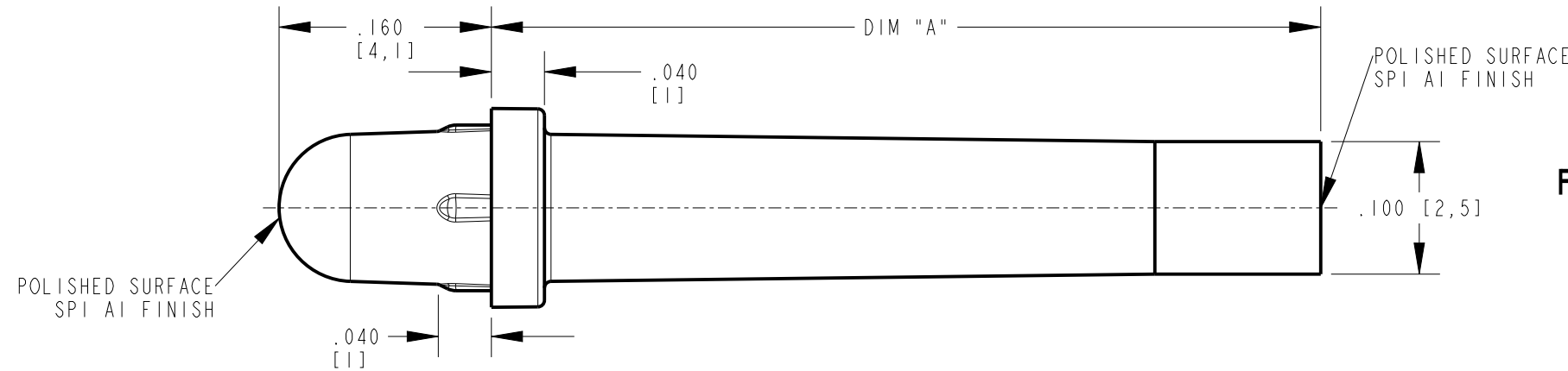
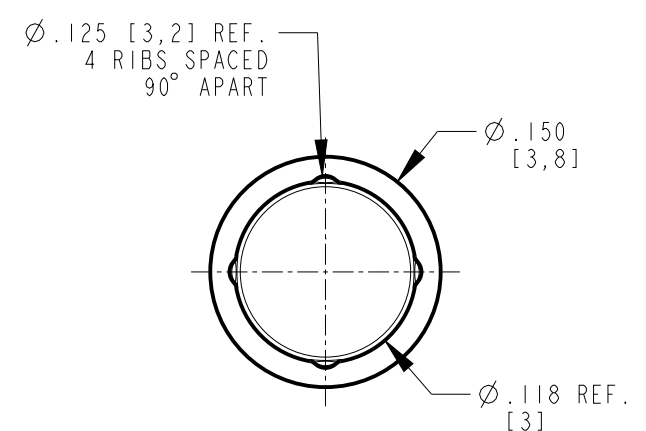
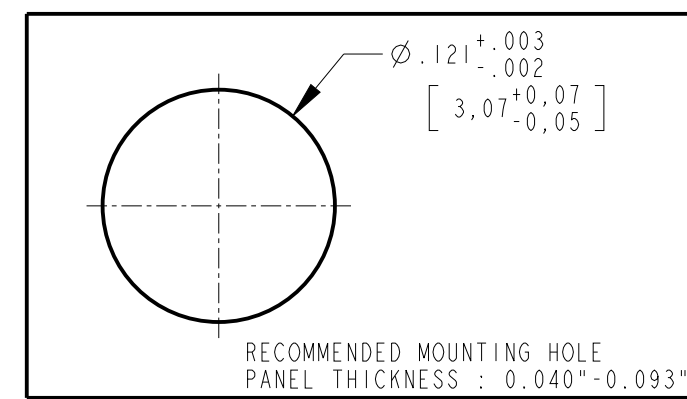
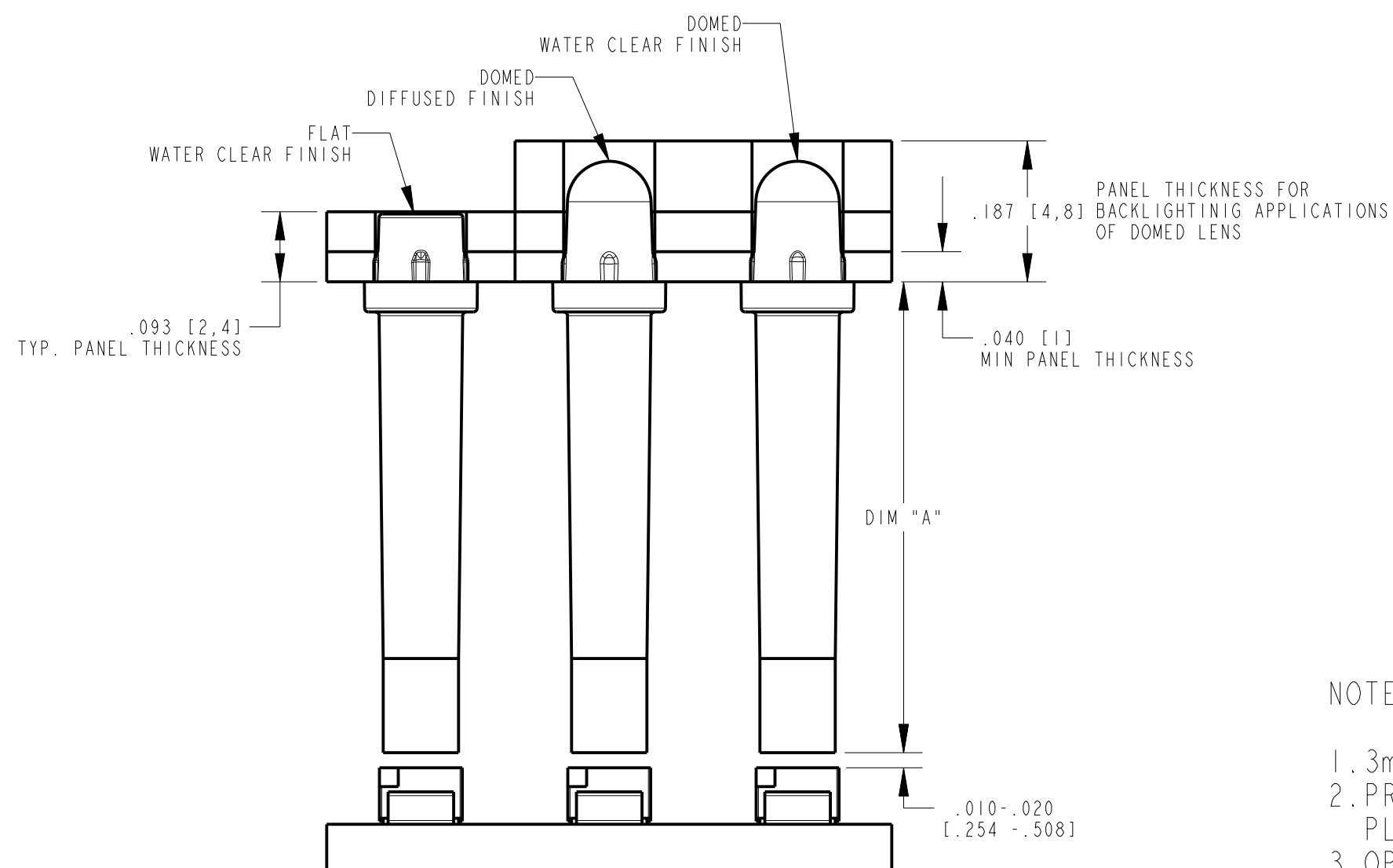

FIGURE 3



NOTES:

- 1.3mm REVERSE(REAR) MOUNT OPTOPIPE® LIGHT PIPES,FLAT AND DOMED
- 2.PRESS FIT FROM REAR OF PANEL BY HAND OR PLASTIC TUBULAR INSERTIONTOOL (SPEC. DWG AVAILABLE FOR TOOL)
- 3.OPTIONAL USE OPTICAL ADHESIVE TO SECURE OPTOPIPE® TO PANEL AFTER ASSEMBLY

REV	ECN NO	REVISIONS	DRN	CKD	DATE
A	97756	NEW RELEASE	JSG	NO	21SEP22

THIS DRAWING AND THE CONTENTS HEREIN ARE CONFIDENTIAL AND THE SOLE PROPERTY OF DIALIGHT CORP. REPRODUCTION OF THIS DRAWING OR CONSTRUCTION OF ANY PARTS WITHIN THIS DRAWING ARE FORBIDDEN WITHOUT THE WRITTEN CONSENT OF DIALIGHT CORP.		
DIALIGHT CORP INTERNAL REFERENCE ONLY - 3D MODEL : 31513040625F-A.8		
SCALE: 8.000	DRAWING NUMBER	REV
ALL DIM'S IN: INCHES (MM)	C-18583	A
TOLERANCES: UNLESS OTHERWISE SPECIFIED	TITLE PRESS FIT 3MM REVERSE MOUNT LIGHT PIPE	
FRACTIONS: ±1/64	MATERIAL	
DECIMALS (.XX): ±.01	FINISH	
DECIMALS (.XXX): ±.005	FSCM 83330	
DECIMALS (.XXXX): ±.0005	SHEET 1 OF 1 FAMILY TABLE:	
ANGLES: ±1°	Dialight 1501 ROUTE 34 SOUTH FARMINGDALE, NJ 07727 (732) 919-3119 www.dialight.com	