

TSL2671

Digital Proximity Detector

General Description

The TSL2671 family of devices provides a complete proximity detection system and digital interface logic in a single 6-pin package. The device includes a digital proximity sensor with integrated LED driver for the required external IR LED. The proximity function offers a wide range of performance, with four programmable LED drive currents and a pulse repetition range of 1 to 32 pulses. The proximity detection circuitry compensates for ambient light, allowing it to operate in environments ranging from bright sunlight to dark rooms. This wide dynamic range also allows operation in short-distance detection applications behind dark glass, such as cell phones. An internal state machine provides the ability to put the device into a low-power mode for very low average power consumption.

The proximity function specifically targets near-field proximity applications. In cell phones, for example, the proximity detection function can detect when the user positions the phone close to their ear. The device is fast enough to provide proximity information at the high repetition rate needed when answering a phone call. This provides both improved green power saving capability and the added security to lock the screen when the user may accidentally deploy a touch.

Communication with the device is accomplished through a simple two-wire I²C interface with data rates up to 400 kHz. An interrupt output pin is provided for connection to the host processor. This interrupt pin can be used to eliminate the need to poll the device on a repetitive basis. There is also a digital filter that compares the proximity ADC results to programmed values so that an interrupt is generated only upon a proximity event.

The TSL2671 is supplied in a very small form factor 2 mm × 2 mm, 6-pin optical package, requiring very little PCB area. Also, the package height is only 0.65 mm high, which makes the TSL2671 suitable for very thin mechanical applications.

[Ordering Information](#) and [Content Guide](#) appear at end of datasheet.

Key Benefits & Features

The benefits and features of TSL2671, Digital Proximity Detector are listed below:

Figure 1:
Added Value Of Using TSL2671

Benefits	Features
<ul style="list-style-type: none"> Enables Operation in IR Light Environments 	<ul style="list-style-type: none"> Patented Dual-Diode Architecture
<ul style="list-style-type: none"> Enables Operation in High Lux Sunlight and Accurate Sensing Behind Spectrally Distorting Materials 	<ul style="list-style-type: none"> 2000:1 Dynamic Range
<ul style="list-style-type: none"> Allows Multiple Power-Level Selection without External Passives 	<ul style="list-style-type: none"> Programmable LED Drive Current
<ul style="list-style-type: none"> Reduces Micro-Processor Interrupt Overhead 	<ul style="list-style-type: none"> Programmable Interrupt Function
<ul style="list-style-type: none"> Reduces Board Space Requirements while Simplifying Designs 	<ul style="list-style-type: none"> Area Efficient 2mm x 2mm Dual Flat No-Lead (FN) Package

- Proximity Detection with an Integrated LED Driver in a Single Device
- Proximity Detection
 - Programmable Number of IR Pulses
 - Programmable Current Sink for the IR LED — No Limiting Resistor Needed
 - Programmable Interrupt Function with Upper and Lower Threshold
 - Covers a 2000:1 Dynamic Range
- Programmable Wait Timer
 - Programmable from 2.72 ms to > 8 Seconds
 - Wait State — 65µA Typical Current
- I²C Interface Compatible
 - Up to 400 kHz (I²C Fast Mode)
 - Dedicated Interrupt Pin
- Small 2 mm × 2 mm ODFN Package
- Sleep Mode — 2.5 µA Typical Current

Applications

TSL2671, Digital Proximity Detector is ideal for:

- Cell Phone Touch Screen Disable
- Notebook/Monitor Security
- Automatic Speakerphone Enable
- Automatic Menu Popup

Functional Block Diagram

The functional blocks of this device are shown below:

Figure 2:
TSL2671 Block Diagram

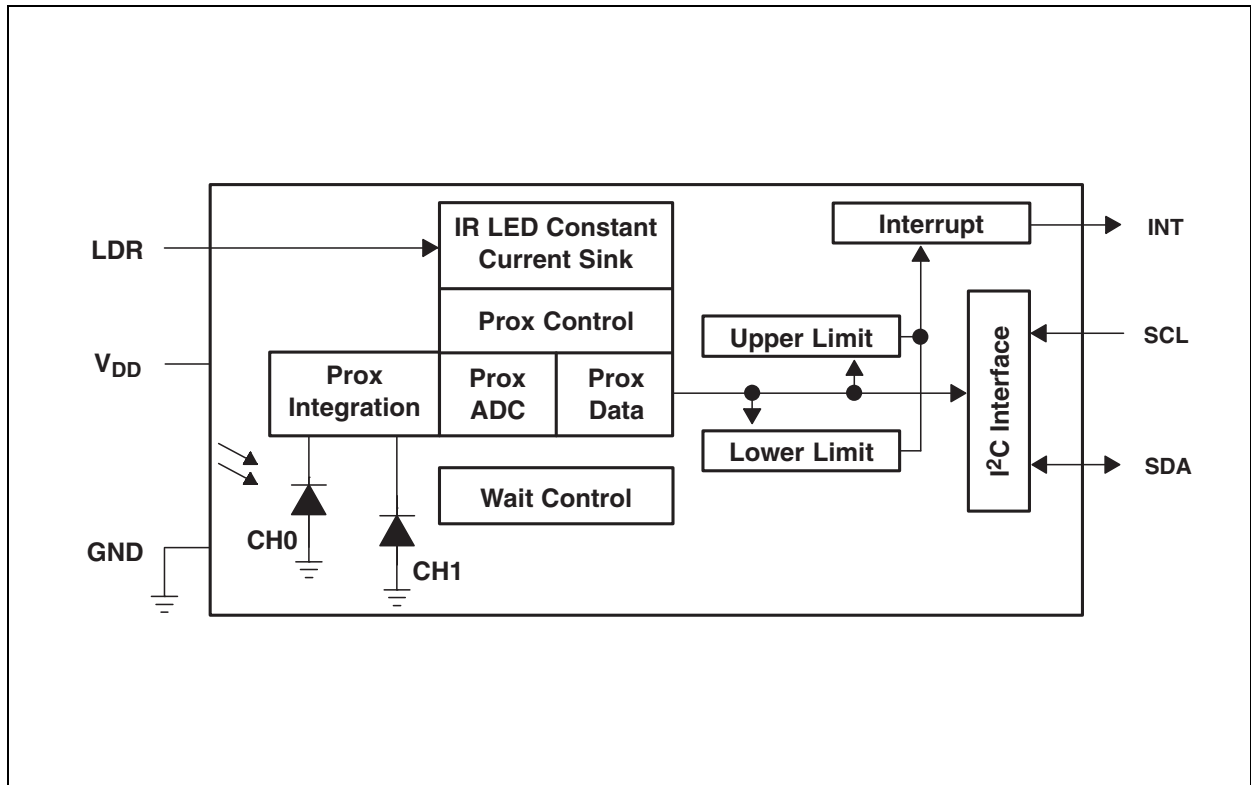

Detailed Description

The TSL2671 light-to-digital device provides on-chip photodiodes, integrating amplifiers, ADCs, accumulators, clocks, buffers, comparators, a state machine, and an I²C interface. Each device combines a Channel 0 photodiode (CH0), which is responsive to both visible and infrared light, and a channel 1 photodiode (CH1), which is responsive primarily to infrared light. Proximity detection can occur using either or both photodiodes. Two integrating ADCs simultaneously convert the amplified photodiode currents into a digital value providing up to 16 bits of resolution. Upon completion of the conversion cycle, the conversion result is transferred to the data registers.

Proximity detection requires only a single external IR LED. An internal LED driver can be configured to provide a constant current sink of 12.5 mA, 25 mA, 50 mA, or 100 mA of current. No external current limiting resistor is required. The number of proximity LED pulses can be programmed from 1 to 255 pulses. Each pulse has a 16- μ s period. This LED current, coupled with the programmable number of pulses, provides a 2000:1 contiguous dynamic range.

Communication to the device is accomplished through a fast (up to 400 kHz), two-wire I²C serial bus for easy connection to a microcontroller or embedded controller. The digital output of the device is inherently more immune to noise when compared to an analog interface.

The device provides a separate pin for level-style interrupts. When interrupts are enabled and a pre-set value is exceeded, the interrupt pin is asserted and remains asserted until cleared by the controlling firmware. The interrupt feature simplifies and improves system efficiency by eliminating the need to poll a sensor for a proximity value. An interrupt is generated when the value of a proximity conversion exceeds either an upper or lower threshold. In addition, a programmable interrupt persistence feature allows the user to determine how many consecutive exceeded thresholds are necessary to trigger an interrupt.

Pin Assignments

The TSL2671 pin assignments are described below:

Figure 3:
Package FN Dual Flat No-Lead (Top View)

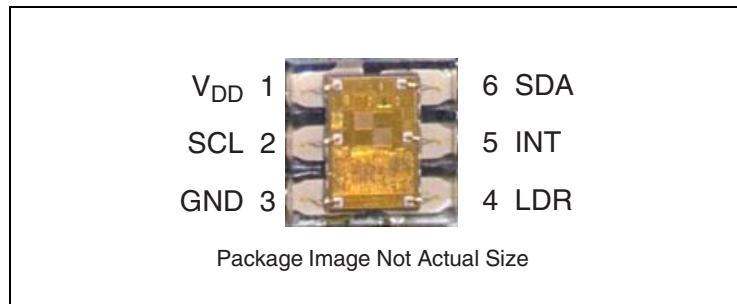

Figure 4:
Terminal Functions

Terminal		Type	Description
Name	No		
V _{DD}	1		Supply voltage.
SCL	2	I	I ² C serial clock input terminal — clock signal for I ² C serial data.
GND	3		Power supply ground. All voltages are referenced to GND.
LDR	4	O	LED driver for proximity emitter — up to 100 mA, open drain.
INT	5	O	Interrupt — open drain
SDA	6	I/O	I ² C serial data I/O terminal — serial data I/O for I ² C.

Absolute Maximum Ratings

Stresses beyond those listed under [Absolute Maximum Ratings](#) may cause permanent damage to the device. These are stress ratings only, and functional operation of the device at these or any other conditions beyond those indicated under [Recommended Operating Conditions](#) is not implied. Exposure to absolute-maximum-rated conditions for extended periods may affect device reliability.

Figure 5:
Absolute Maximum Ratings Over Operating Free-Air Temperature Range (unless otherwise noted)

Symbol	Parameter	Min	Max	Units
$V_{DD}^{(1)}$	Supply voltage		3.8	V
V_O	Digital output voltage range	-0.5	3.8	V
I_O	Digital output current	-1	+20	mA
T_{STRG}	Storage temperature range	-40	85	°C
ESD_{HBM}	ESD tolerance, human body model	±2000		V

Note(s):

1. All voltages are with respect to GND.

Figure 6:
Recommended Operating Conditions

Parameter	Min	Nom	Max	Units
Supply voltage, V_{DD}	2.6	3	3.6	V
Supply voltage accuracy, V_{DD} total error including transients	-3		3	%
Operating free-air temperature, T_A	-30		70	°C

Operating Characteristics

$V_{DD} = 3\text{ V}$, $T_A = 25^\circ\text{C}$ (unless otherwise noted)

Figure 7:
Operating Characteristics

Symbol	Parameter	Test Conditions	Min	Typ	Max	Unit
I_{DD}	Supply current	Active — LDR pulse off		175	250	μA
		Wait mode		65		
		Sleep mode		2.5	4	
V_{OL}	INT, SDA output low voltage	3 mA sink current	0		0.4	V
		6 mA sink current	0		0.6	
I_{LEAK}	Leakage current, SDA, SCL, INT pins		-5		5	μA
I_{LEAK}	Leakage current, LDR pin			± 10		μA
V_{IH}	SCL, SDA input high voltage	TSL26711, TSL26715	$0.7V_{DD}$			V
		TSL26713, TSL26717	1.25			
V_{IL}	SCL, SDA input low voltage	TSL26711, TSL26715			$0.3V_{DD}$	V
		TSL26713, TSL26717			0.54	

Proximity Characteristics

$V_{DD} = 3\text{ V}$, $T_A = 25^\circ\text{C}$, PEN = 1 (unless otherwise noted)

Figure 8:
Proximity Characteristics

Parameter	Test Conditions	Condition	Min	Typ	Max	Unit
I_{DD} Supply current	LDR pulse on			3		mA
ADC conversion time step size	PTIME = 0xFF		2.58	2.72	2.9	ms
ADC number of integration steps			1		256	steps
ADC counts per step	PTIME = 0xFF		0		1023	counts
IR LED pulse count			0		255	pulses
Pulse period				16.3		μs
Pulse — LED on time				7.2		μs
LED Drive	I_{SINK} sink current @ 600 mV, LDR pin	PDRIVE=0	75	100	125	mA
		PDRIVE=1		50		
		PDRIVE=2		25		
		PDRIVE=3		12.5		
Operating distance ⁽¹⁾				18		inches

Note(s):

- Proximity Operating Distance is dependent upon emitter properties and the reflective properties of the proximity surface. The nominal value shown uses an IR emitter with a peak wavelength of 850 nm and a 20° half angle. The proximity surface used is 90% reflective (white surface) 16 × 20-inch Kodak Gray Card. 60 mw/SR, 100 mA, 64 pulses, open view (no glass). Greater distances are achievable with appropriate system considerations.

Wait Characteristics

$V_{DD} = 3\text{ V}$, $T_A = 25^\circ\text{C}$, WEN = 1 (unless otherwise noted)

Figure 9:
Wait Characteristics

Parameter	Test Conditions	Channel	Min	Typ	Max	Unit
Wait step size	WTIME = 0xFF		2.58	2.72	2.9	ms
Wait number of integration steps			1		256	steps

AC Electrical Characteristics $V_{DD} = 3\text{ V}$, $T_A = 25^\circ\text{C}$, (unless otherwise noted)**Figure 10:**
AC Electrical Characteristics

Symbol	Parameter ⁽¹⁾	Test Conditions	Min	Typ	Max	Unit
$f_{(SCL)}$	Clock frequency (I ² C only)		0		400	kHz
$t_{(BUF)}$	Bus free time between start and stop condition		1.3			μs
$t_{(HDSTA)}$	Hold time after (repeated) start condition. After this period, the first clock is generated.		0.6			μs
$t_{(SUSTA)}$	Repeated start condition setup time		0.6			μs
$t_{(SUSTO)}$	Stop condition setup time		0.6			μs
$t_{(HDDAT)}$	Data hold time		0			μs
$t_{(SUDAT)}$	Data setup time		100			ns
$t_{(LOW)}$	SCL clock low period		1.3			μs
$t_{(HIGH)}$	SCL clock high period		0.6			μs
t_F	Clock/data fall time				300	ns
t_R	Clock/data rise time				300	ns
C_i	Input pin capacitance				10	pF

Note(s):

1. Specified by design and characterization; not production tested.

Parameter Measurement Information

Figure 11:
Timing Diagrams

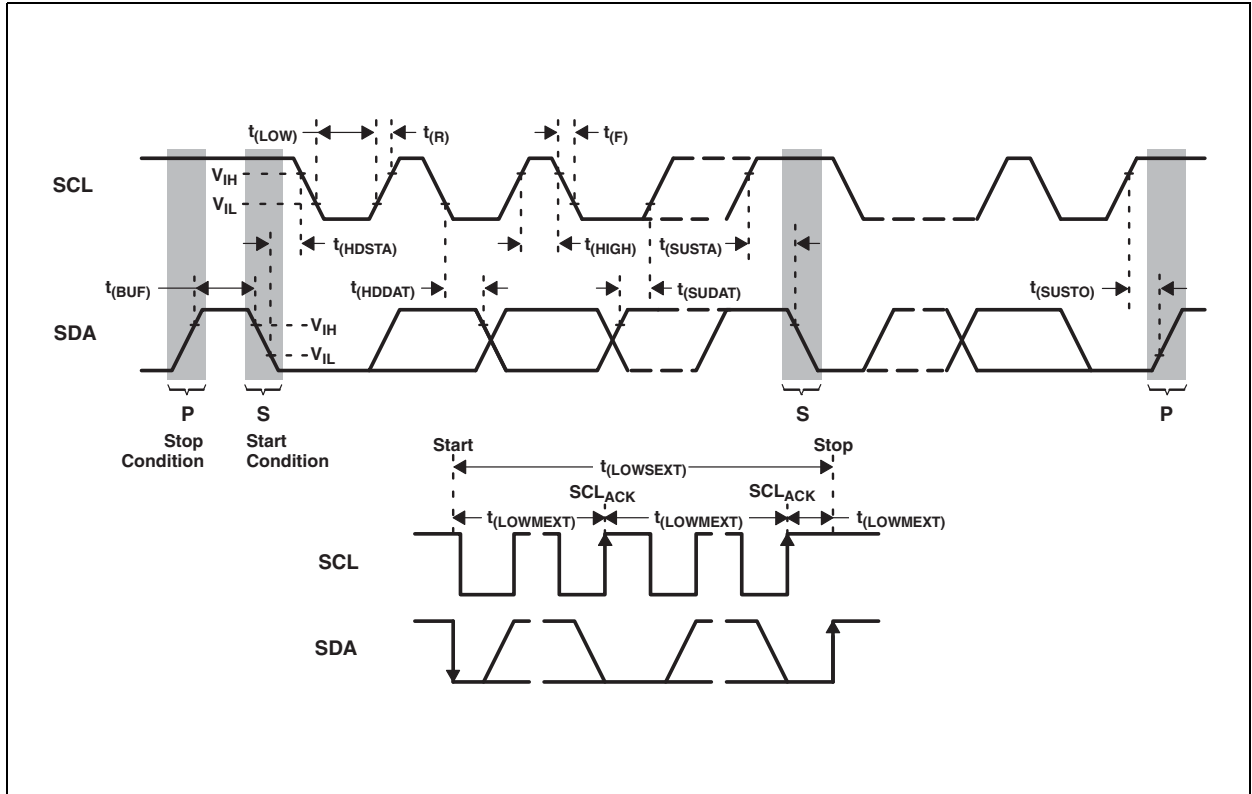

Typical Characteristics

Figure 12:
Spectral Responsivity

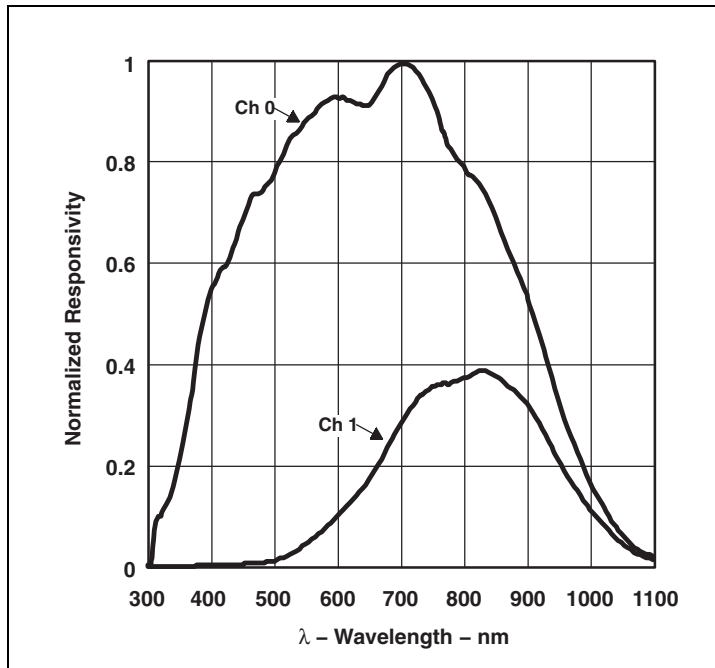

Figure 13:
LDR Output Compliance

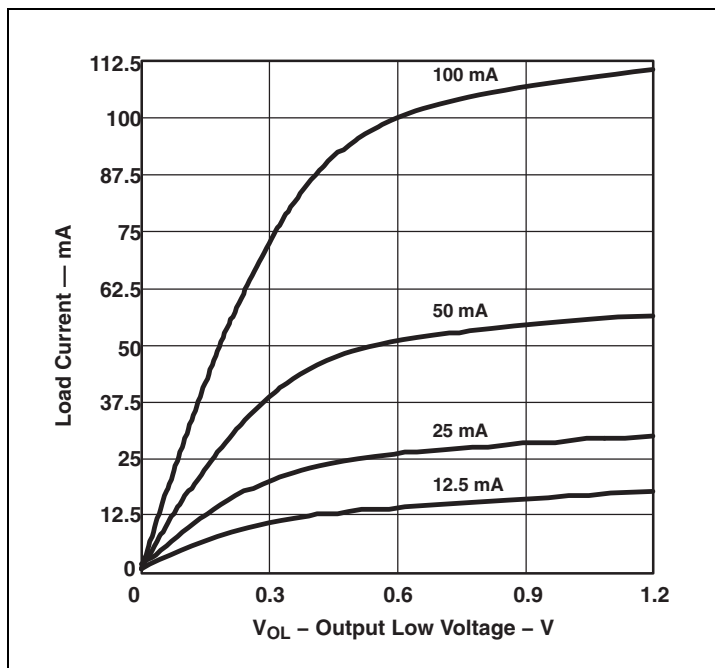
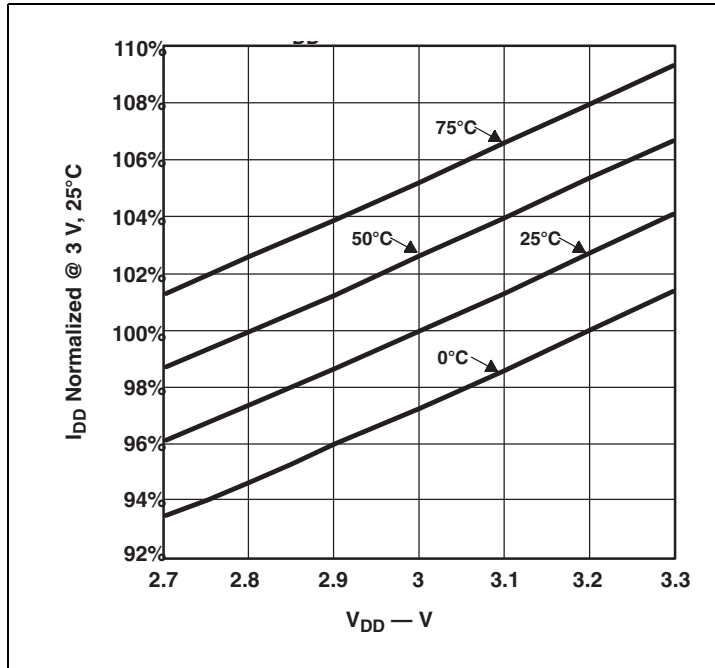

Figure 14:
Normalized I_{DD} vs. V_{DD} and Temperature



Principles of Operation

System State Machine

The device provides control of proximity detection and power management functionality through an internal state machine. After a power-on-reset, the device is in the sleep mode. As soon as the PON bit is set, the device will move to the start state. It will then cycle through the Proximity and Wait states. If these states are enabled, the device will execute each function. If the PON bit is set to a 0, the state machine will continue until the current conversion is complete and then go into a low-power sleep mode.

Figure 15:
Simplified State Diagram

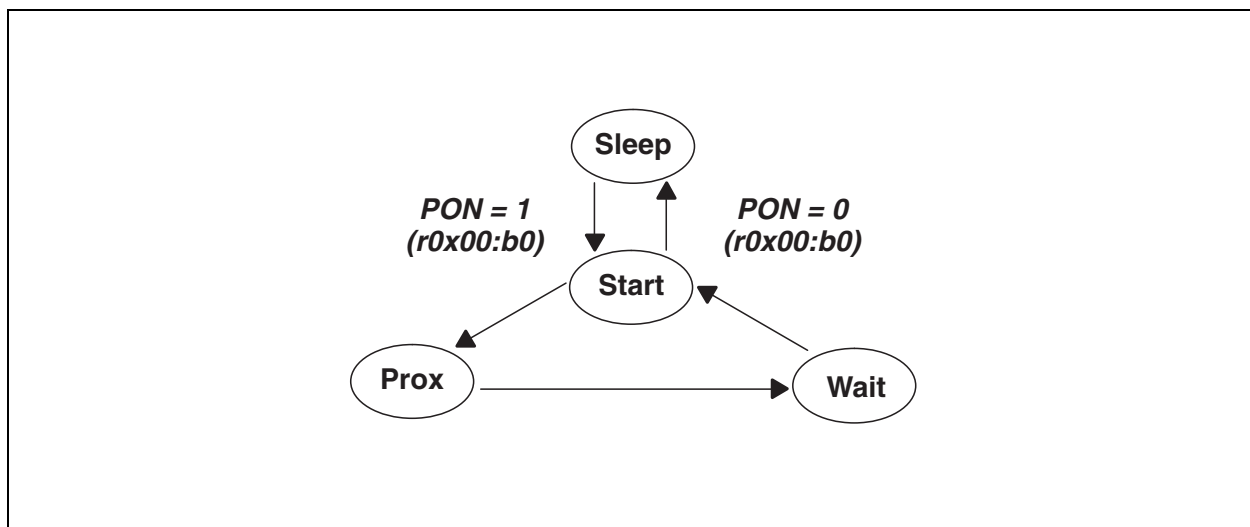

Note(s):

1. In this document, the nomenclature uses the bit field name in italics followed by the register number and bit number to allow the user to easily identify the register and bit that controls the function. For example, the power on (PON) is in register 0x00, bit 0. This is represented as *PON (r0x00:b0)*.

Proximity Detection

Proximity sensing uses an external light source (generally an infrared emitter) to emit light, which is then viewed by the integrated light detector to measure the amount of reflected light when an object is in the light path (Figure 16). The amount of light detected from a reflected surface can then be used to determine an object's proximity to the sensor.

Figure 16: Proximity Detection

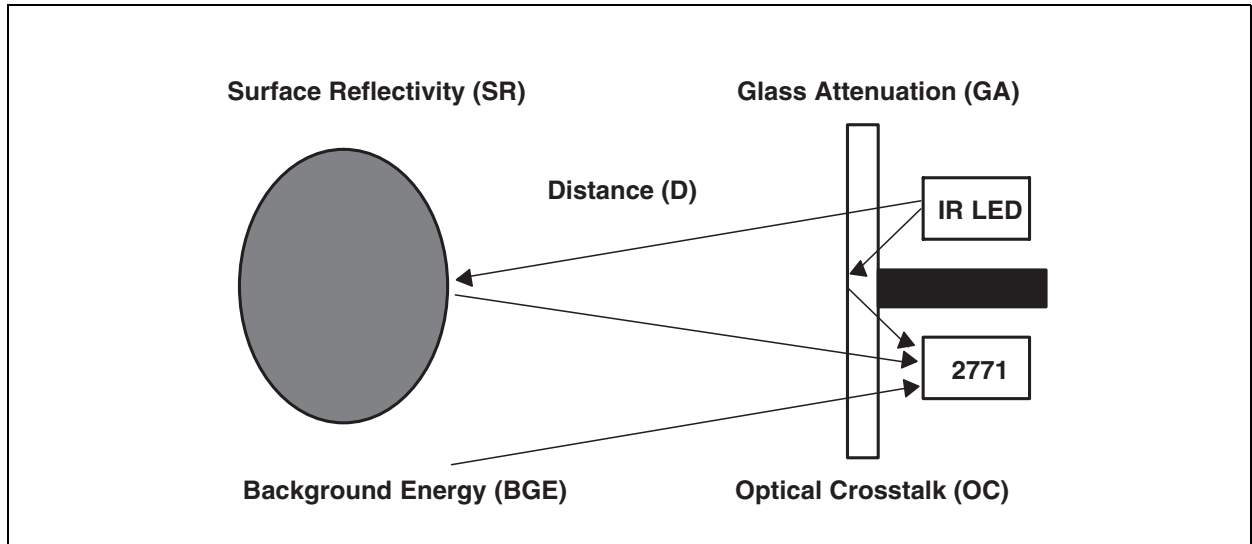

The device has controls for the number of IR pulses (PPCOUNT), the integration time (PTIME), the LED drive current (PDRIVE), and the photodiode configuration (PDIODE) (Figure 17). The photodiode configuration can be set to CH1 diode (recommended), CH0 diode, or a combination of both diodes. At the end of the integration cycle, the results are latched into the proximity data (PDATAx) registers.

Figure 17: Proximity Detection Operation

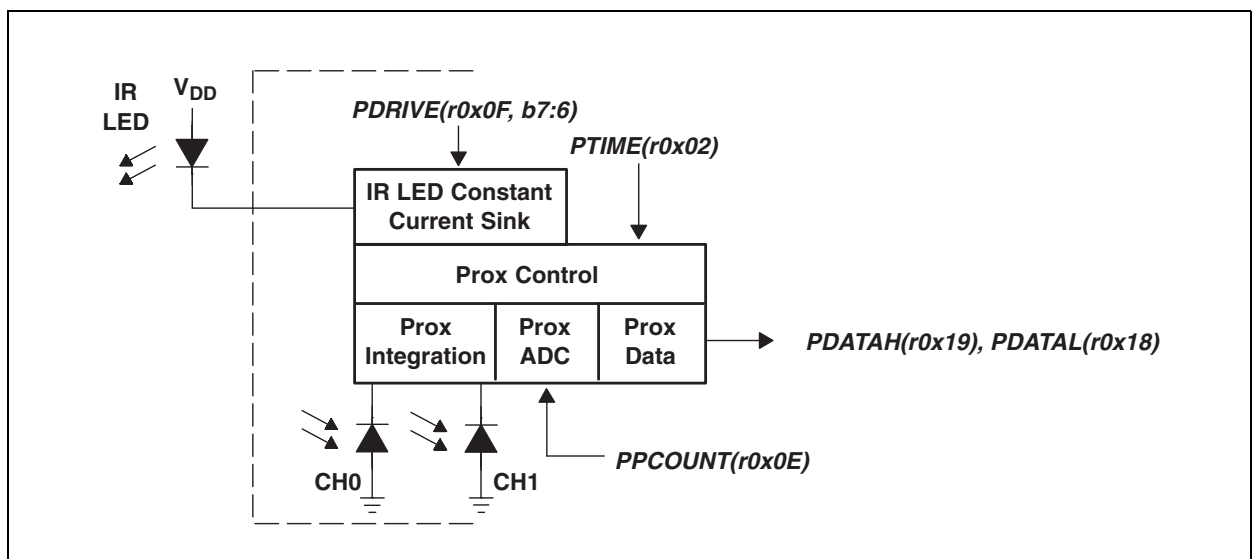

The LED drive current is controlled by a regulated current sink on the LDR pin. This feature eliminates the need to use a current limiting resistor to control LED current. The LED drive current can be configured for 12.5 mA, 25 mA, 50 mA, or 100 mA. For higher LED drive requirements, an external P type transistor can be used to control the LED current.

The number of LED pulses can be programmed to any value between 1 and 255 pulses as needed. Increasing the number of LED pulses at a given current will increase the sensor sensitivity. Sensitivity grows by the square root of the number of pulses. Each pulse has a 16- μ s period.

Figure 18:
Proximity IR LED Waveform

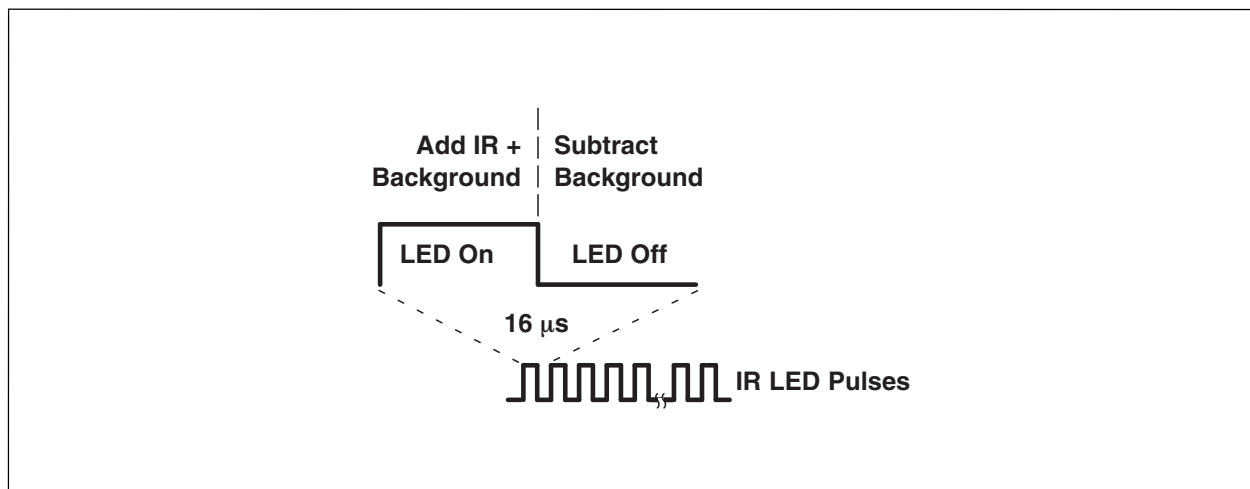

The proximity integration time (PTIME) is the period of time that the internal ADC converts the analog signal to a digital count. It is recommend that this be set to a minimum of PTIME = 0xFF or 2.72 ms.

The combination of LED power and number of pulses can be used to control the distance at which the sensor can detect proximity. [Figure 19](#) shows an example of the distances covered with settings such that each curve covers 2X the distance. Counts up to 64 pulses provide a 16X range.

Figure 19:
Proximity ADC Count vs. Relative Distance

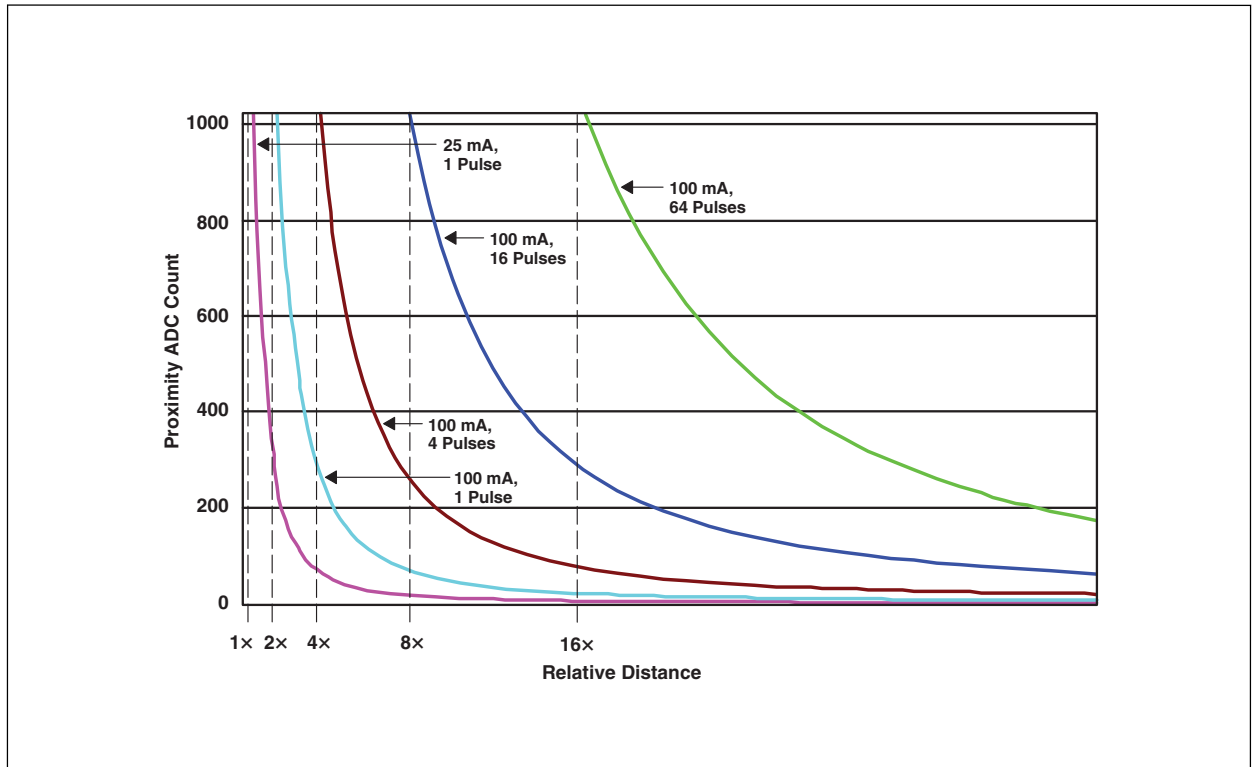

Interrupts

The interrupt feature simplifies and improves system efficiency by eliminating the need to poll the sensor for a proximity value. The interrupt mode is determined by the state of the PIEN field in the ENABLE register.

Two 16-bit-wide interrupt threshold registers allow the user to define upper and lower threshold limits. An interrupt can be generated when the proximity data (PDATA) exceeds the upper threshold value (PIHTx) or falls below the lower threshold (PILTx).

To further control when an interrupt occurs, the device provides an interrupt persistence feature. This feature allows the user to specify a number of conversion cycles for which an event exceeding the proximity interrupt threshold must persist (PPERS) before actually generating an interrupt. See the register descriptions for details on the length of the persistence.

Figure 20:
Programmable Interrupt

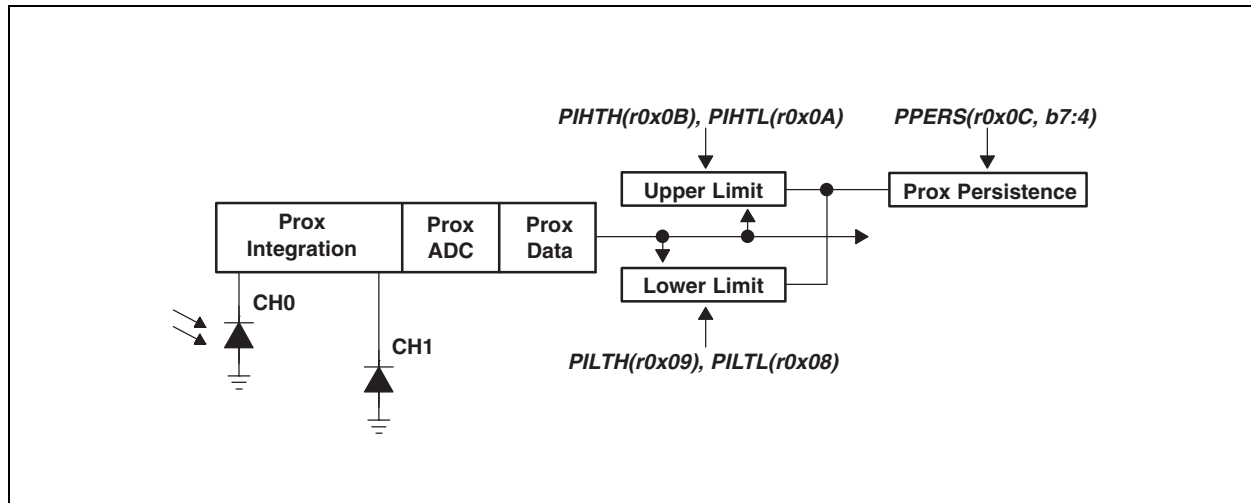

State Diagram

The following state diagram shows a more detailed flow for the state machine. The device starts in the sleep mode. The PON bit is written to enable the device. A 2.72-ms Start Delay will occur before entering the start state. If the PEN bit is set, the state machine will step through the proximity accumulate, then proximity ADC conversion states. As soon as the conversion is complete, the state machine will move to the Wait Check state. If the WEN bit is set, the state machine will then cycle through the wait state. If the WLONG bit is set, the wait cycles are extended by 12X over normal operation. When the wait counter terminates, the state machine will move to the 2.72-ms Wait Delay state before returning to the Start state.

Figure 21:
Expanded State Diagram

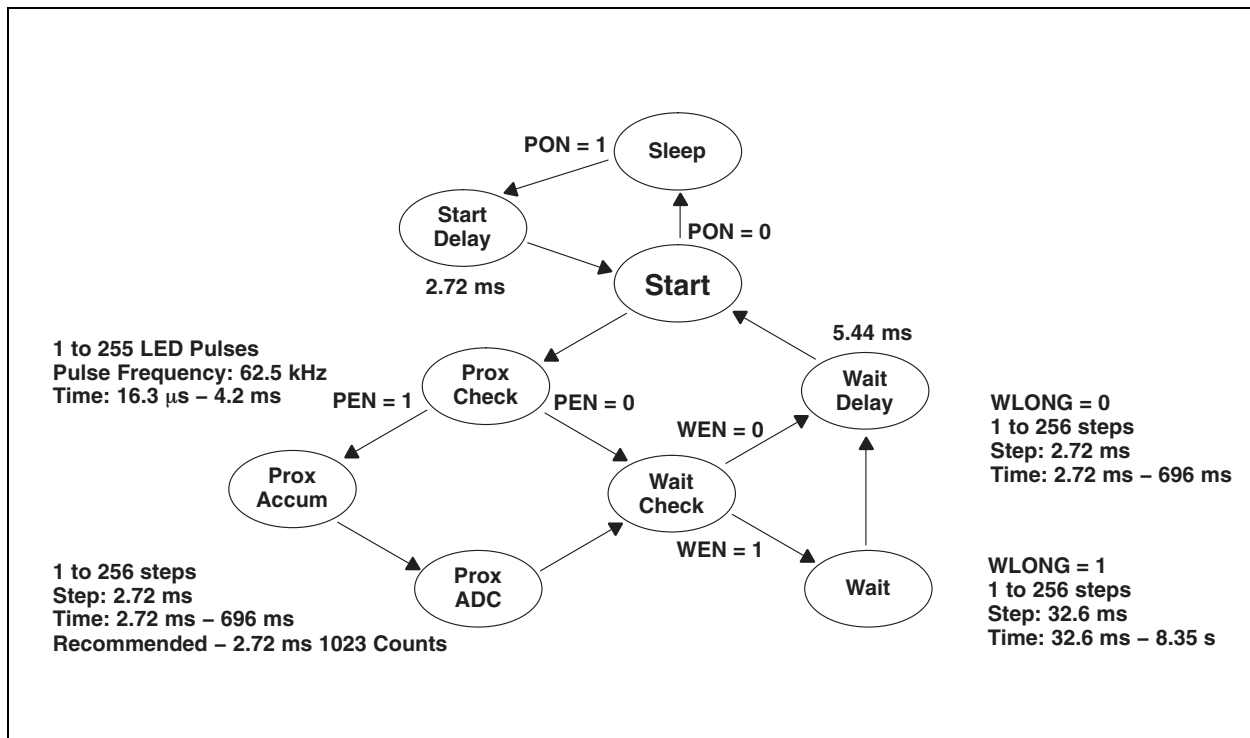

Power Management

Power consumption can be controlled through the use of the wait state timing because the wait state consumes only 65 μA of power. Figure 37 shows an example of using the power management feature to achieve an average power consumption of 138 μA current with four 100-mA pulses of proximity detection.

Figure 22:
Power Consumption Calculations

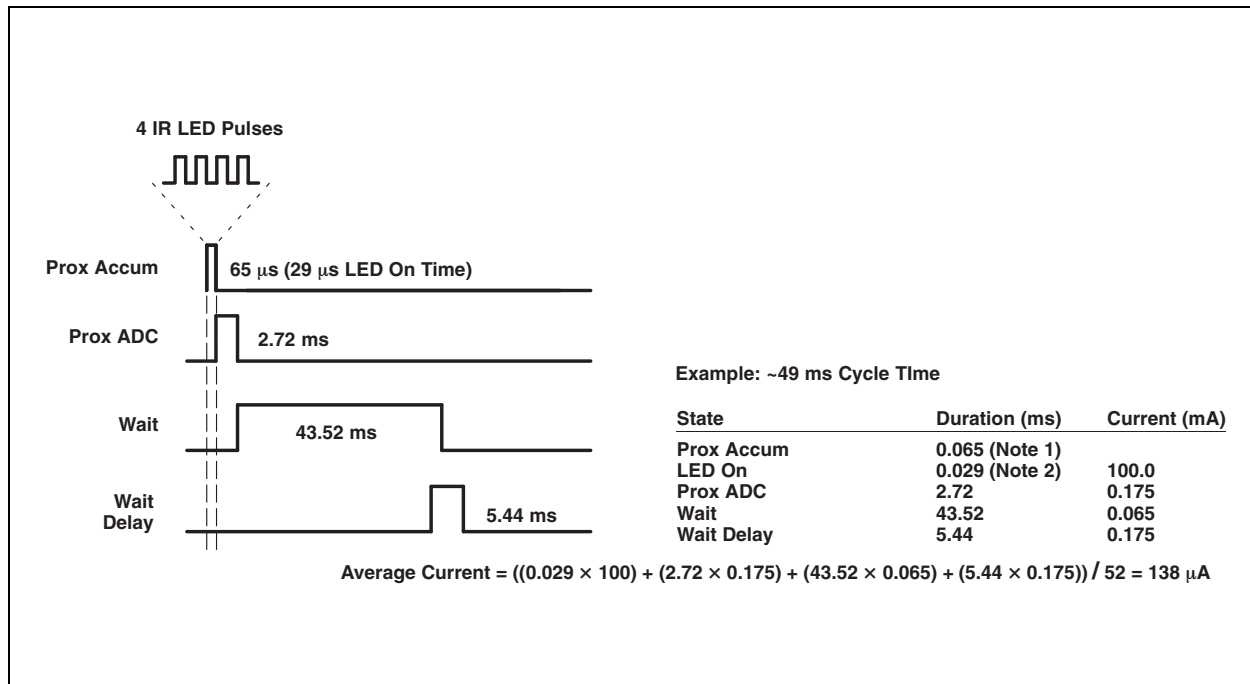

Note(s):

1. Prox Accum = 16.3 μs per pulse \times 4 pulses = 65 μs = 0.065 ms
2. LED On = 7.2 μs per pulse \times 4 pulses = 29 μs = 0.029 ms

I²C Protocol

Interface and control are accomplished through an I²C serial compatible interface (standard or fast mode) to a set of registers that provide access to device control functions and output data. The devices support the 7-bit I²C addressing protocol. Devices TSL26711 and TSL26713 are at slave address 0x39, while the TSL26715 and TSL26717 devices are at slave address 0x29.

The I²C standard provides for three types of bus transaction: read, write, and a combined protocol (see [Figure 23](#)). During a write operation, the first byte written is a command byte followed by data. In a combined protocol, the first byte written is the command byte followed by reading a series of bytes. If a read command is issued, the register address from the previous command will be used for data access. Likewise, if the MSB of the command is not set, the device will write a series of bytes at the address stored in the last valid command with a register address. The command byte contains either control information or a 5-bit register address. The control commands can also be used to clear interrupts.

The I²C bus protocol was developed by Philips (now NXP). For a complete description of the I²C protocol, please review the NXP I²C design specification at <http://www.i2c-bus.org/references/>.

Figure 23:
I²C Protocols

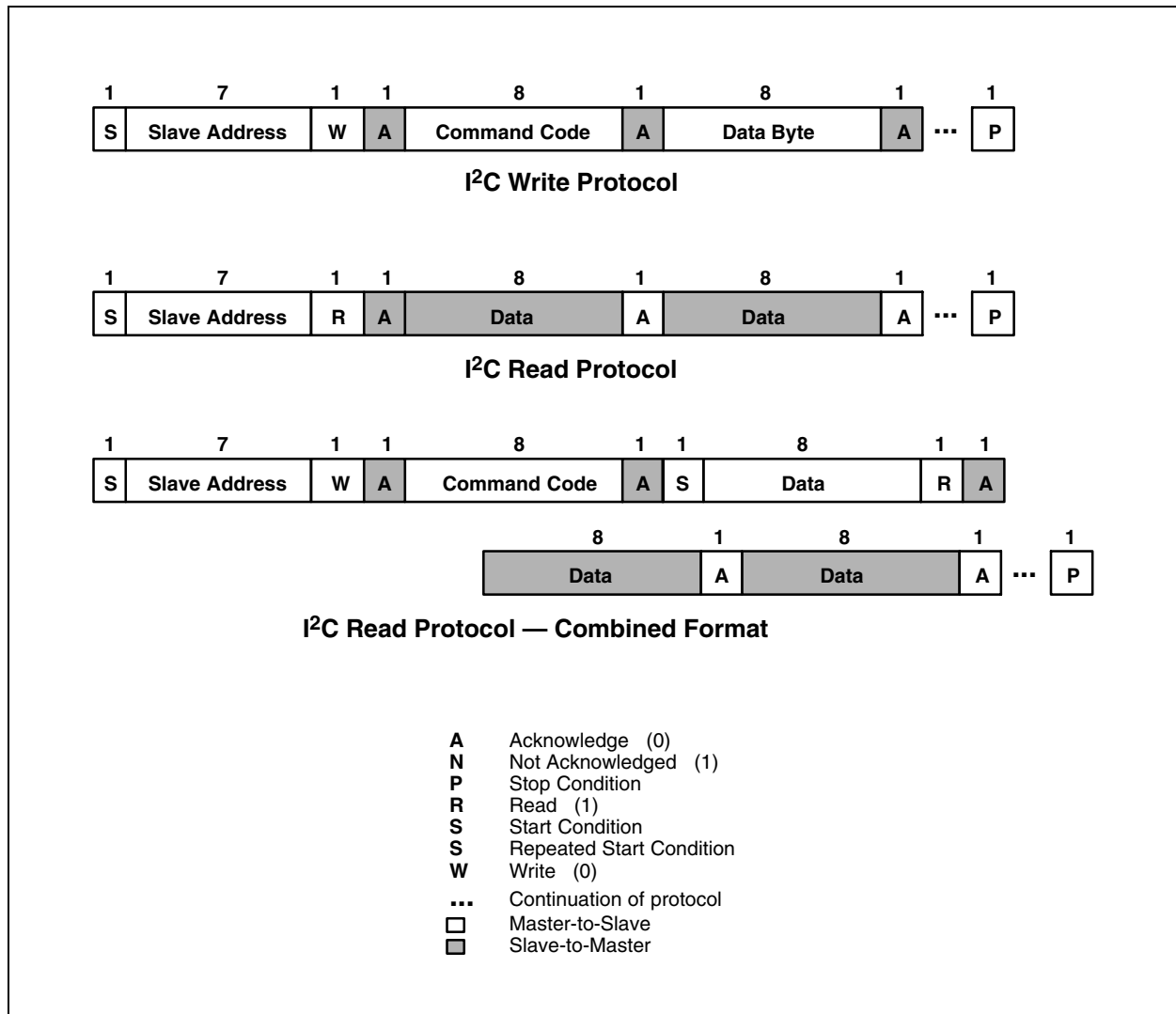

Register Description

Register Set

The device is controlled and monitored by data registers and a command register accessed through the serial interface. These registers provide for a variety of control functions and can be read to determine results of the ADC conversions. The register set is summarized in [Figure 24](#).

Figure 24:
Register Address

Address	Register Name	R/W	Register Function	Reset Value
--	COMMAND	W	Specifies register address	0x00
0x00	ENABLE	R/W	Enables states and interrupts	0x00
0x02	PTIME	R/W	Proximity ADC time	0xFF
0x03	WTIME	R/W	Wait time	0xFF
0x08	PILTL	R/W	Proximity interrupt low threshold low byte	0x00
0x09	PILTH	R/W	Proximity interrupt low threshold high byte	0x00
0x0A	PIHTL	R/W	Proximity interrupt high threshold low byte	0x00
0x0B	PIHTH	R/W	Proximity interrupt high threshold high byte	0x00
0x0C	PERS	R/W	Interrupt persistence filters	0x00
0x0D	CONFIG	R/W	Configuration	0x00
0x0E	PPCOUNT	R/W	Proximity pulse count	0x00
0x0F	CONTROL	R/W	Control register	0x00
0x12	ID	R	Device ID	ID
0x13	STATUS	R	Device status	0x00
0x18	PDATAH	R	Proximity ADC high data register	0x00
0x19	PDATAH	R	Proximity ADC high data register	0x00

The mechanics of accessing a specific register depends on the specific protocol used. See the section on I²C protocols on the previous pages. In general, the COMMAND register is written first to specify the specific control/status register for following read/write operations.

Command Register

The command registers specifies the address of the target register for future write and read operations.

Figure 25:
Command Register

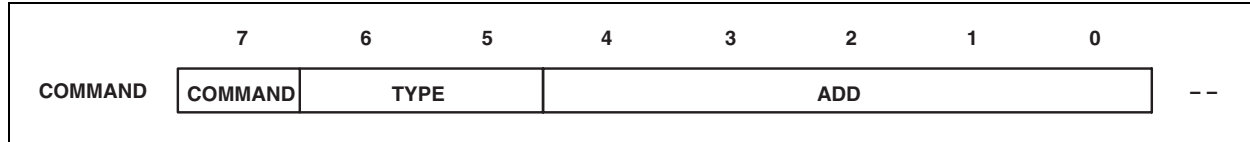

Field	Bits	Description	
COMMAND	7	Select Command Register. Must write as 1 when addressing COMMAND register.	
TYPE	6:5	Selects type of transaction to follow in subsequent data transfers:	
		FIELD VALUE	DESCRIPTION
		00	Repeated byte protocol transaction
		01	Auto-increment protocol transaction
		10	Reserved — Do not use
		11	Special function — See description below
		Transaction type 00 will repeatedly read the same register with each data access. Transaction type 01 will provide an auto-increment function to read successive register bytes.	
ADD	4:0	Address register/special function register. Depending on the transaction type, see above, this field either specifies a special function command or selects the specific control-status-register for following write and read transactions:	
		FIELD VALUE	DESCRIPTION
		00000	Normal — No action
		00101	Proximity interrupt clear
		Proximity Interrupt Clear clears any pending proximity interrupt. This special function is self clearing.	

Enable Register (0x00)

The ENABLE register is used to power the device on/off, enable functions, and interrupts.

Figure 26:
Enable Register

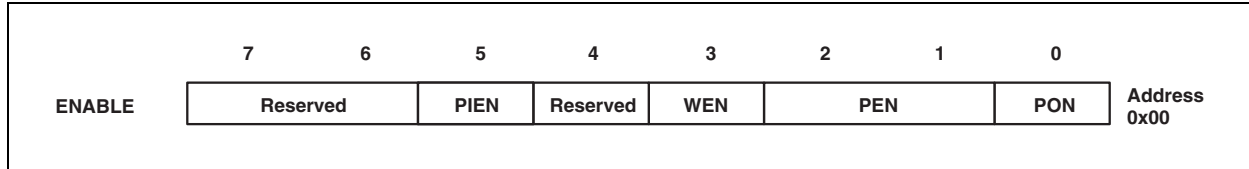

Field	Bits	Description
Reserved	7:6	Reserved. Write as 0.
PIEN	5	Proximity interrupt mask. When asserted, permits proximity interrupts to be generated.
Reserved	4	Reserved. Write as 0.
WEN	3	Wait enable. This bit activates the wait feature. Writing a 1 activates the wait timer. Writing a 0 disables the wait timer.
PEN	2:1	Proximity enable. These bits activate the proximity function. Writing a 11b enables proximity. Writing a 00b disables proximity. The Wait Time register should be configured before asserting proximity enable.
PON ^{(1) (2)}	0	Power ON. This bit activates the internal oscillator to permit the timers and ADC channel to operate. Writing a 1 activates the oscillator. Writing a 0 disables the oscillator.

Note(s):

1. See Power Management section for more information.
2. A minimum interval of 2.72 ms must pass after PON is asserted before proximity can be initiated. This required time is enforced by the hardware in cases where the firmware does not provide it.

Proximity Time Control Register (0x02)

The proximity timing register controls the integration time of the proximity ADC in 2.72 ms increments. It is recommended that this register be programmed to a value of 0xFF (1 integration cycle).

Figure 27:
Proximity Time Control Register

Field	Bits	Description			
		Value	Integ_Cycles	Time	Max Count
PTIME	7:0	0xFF	1	2.72 ms	1023

Wait Time Register (0x03)

Wait time is set 2.72 ms increments unless the WLONG bit is asserted in which case the wait times are 12X longer. WTIME is programmed as a 2's complement number.

Figure 28:
Wait Time Register

Field	Bits	Description			
		Register Value	Wait Time	Time (WLONG = 0)	Time (WLONG = 1)
WTIME	7:0	0xFF	1	2.72 ms	0.032 s
		0xB6	74	201 ms	2.4 s
		0x00	256	696 ms	8.3 s

Note(s):

1. The Wait Time Register should be configured before PEN is asserted.

Proximity Interrupt Threshold Registers (0x08 - 0x0B)

The proximity interrupt threshold registers provide the values to be used as the high and low trigger points for the comparison function for interrupt generation. If the value generated by proximity channel crosses below the lower threshold specified, or above the higher threshold, an interrupt is signaled to the host processor.

Figure 29:
Proximity Interrupt Threshold Registers

Register	Address	Bits	Description
PILTL	0x08	7:0	Proximity low threshold lower byte
PILTH	0x09	7:0	Proximity low threshold upper byte
PIHTL	0x0A	7:0	Proximity high threshold lower byte
PIHTH	0x0B	7:0	Proximity high threshold upper byte

Persistence Register (0x0C)

The persistence register controls the filtering interrupt capabilities of the device. Configurable filtering is provided to allow interrupts to be generated after each ADC integration cycle or if the ADC integration has produced a result that is outside of the values specified by threshold register for some specified amount of time.

Figure 30:
Persistence Register

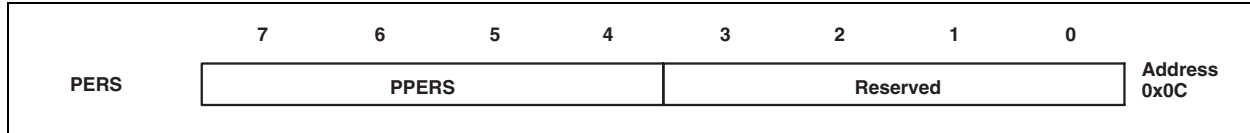

Field	Bits	Description		
PPERS	7:4	Proximity interrupt persistence. Controls rate of proximity interrupt to the host processor		
		Field Value	Meaning	Interrupt Persistence Function
		0000	---	Every proximity cycle generates an interrupt
		0001	1	1 proximity value out of range
		0010	2	2 consecutive proximity values out of range
	
		1111	15	15 consecutive proximity values out of range
Reserved	3:0	Default setting is 0x00.		

Configuration Register (0x0D)

The configuration register sets the wait long time.

Figure 31:
Configuration Register

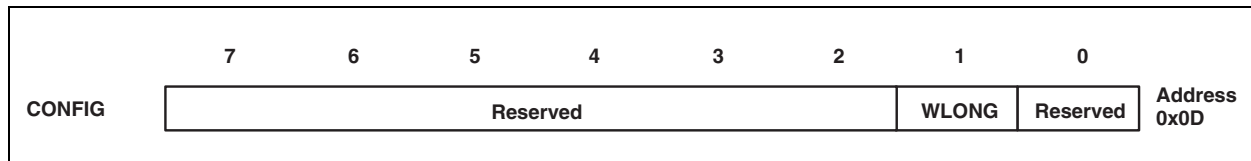

Field	Bits	Description
Reserved	7:2	Reserved. Write as 0.
WLONG	1	Wait Long. When asserted, the wait cycles are increased by a factor 12X from that programmed in the WTIME register.
Reserved	0	Reserved. Write as 0.

Proximity Pulse Count Register (0x0E)

The proximity pulse count register sets the number of proximity pulses that will be transmitted. PPULSE defines the number of pulses to be transmitted at a 62.5-kHz rate.

While the value can be programmed up to 255 pulses, the practical limit of the device is 32 pulses. It is recommended that 32 or fewer pulses be used to achieve maximum signal-to-noise ratio.

Figure 32:
Proximity Pulse Count Register

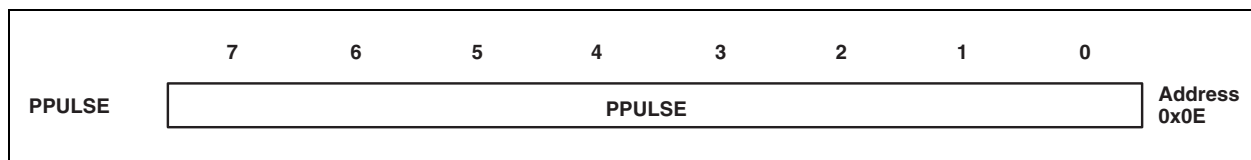

Field	Bits	Description
PPULSE	7:0	Proximity Pulse Count. Specifies the number of proximity pulses to be generated.

Control Register (0x0F)

The Control register provides four bits of control to the analog block. These bits control the diode drive current and diode selection functions.

Figure 33:
Control Register

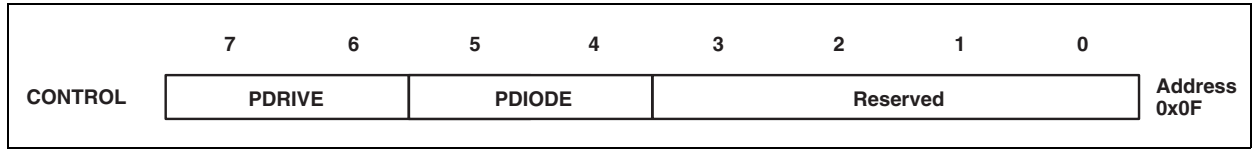

Field	Bits	Description	
PDRIVE	7:6	LED Drive Strength.	
		Field Value	LED Strength
		00	100 mA
		01	50 mA
		10	25 mA
		11	12.5 mA
PDIODE	5:4	Proximity Diode Select.	
		Field Value	Diode Selection
		00	Reserved
		01	Proximity uses the Channel 0 diode
		10	Proximity uses the Channel 1 diode
		11	Proximity uses both diodes
Reserved	3:0	Reserved. Write bits as 0.	

ID Register (0x12)

The ID Register provides the value for the part number. The ID register is a read-only register.

Figure 34:
ID Register

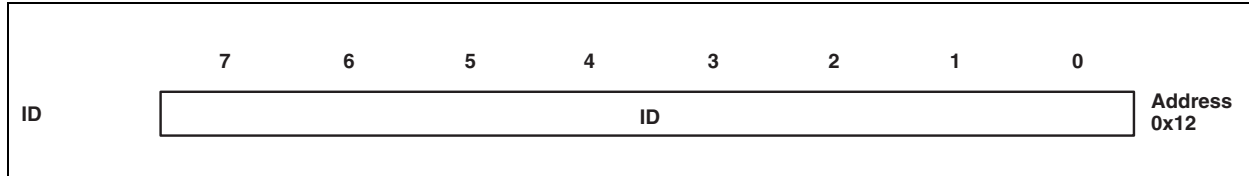

Field	Bits	Description	
ID	7:0	Part number identification	0x00 = TSL26711 & TSL26715
			0x09 = TSL26713 & TSL26717

Status Register (0x13)

The Status Register provides the internal status of the device. This register is read only.

Figure 35:
Status Register

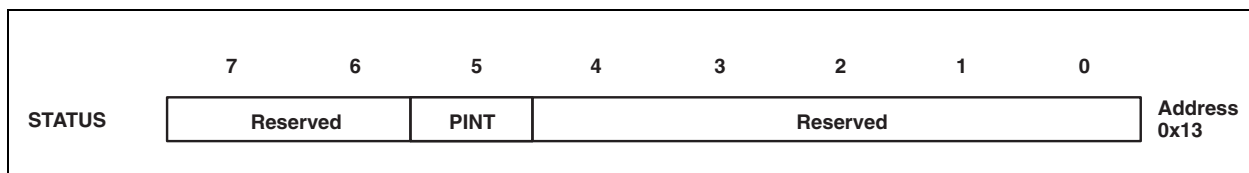

Field	Bit	Description
Reserved	7:6	Reserved.
PINT	5	Proximity Interrupt. Indicates that the device is asserting a proximity interrupt.
Reserved	4:0	Reserved.

Proximity Data Registers (0x18 - 0x19h)

Proximity data is stored as a 16-bit value. To ensure the data is read correctly, a two-byte I²C read transaction should be utilized with auto increment protocol bits set in the command register. With this operation, when the lower byte register is read, the upper eight bits are stored into a shadow register, which is read by a subsequent read to the upper byte. The upper register will read the correct value even if the next ADC cycle ends between the reading of the lower and upper registers.

Figure 36:
Proximity Data Registers

Register	Address	Bits	Description
PDATA_L	0x18	7:0	Proximity data low byte
PDATA_H	0x19	7:0	Proximity data high byte

Application Information: Hardware

LED Driver Pin with Proximity Detection

The application hardware circuit with proximity detection requires an LED connected as shown in Figure 37. V_{bat} may be an independent power source. The 1- μF decoupling capacitors should be of the low-ESR type and be placed as close as possible to the load and V_{DD} to reduce noise. To maximize system performance, the use of PCB power and ground planes are recommended. If mounted on a flexible circuit, the power and ground traces back to the PCB should be sufficiently wide enough to have a low resistance, such as $< 1\ \Omega$.

The I²C bus protocol was developed by Philips (now NXP). The pull-up resistor value (R_p) is a function of the I²C bus speed, the supply voltage, and the capacitive bus loading. Users should consult the NXP I²C design specification (<http://www.i2c.bus.org/references/>) for assistance. With a lightly loaded bus running at 400 kbps and $V_{DD} = 3\ \text{V}$, 1.5-k Ω resistors have been found to be viable.

Figure 37:
Application Hardware Circuit for Proximity Sensing with Internal LED Driver

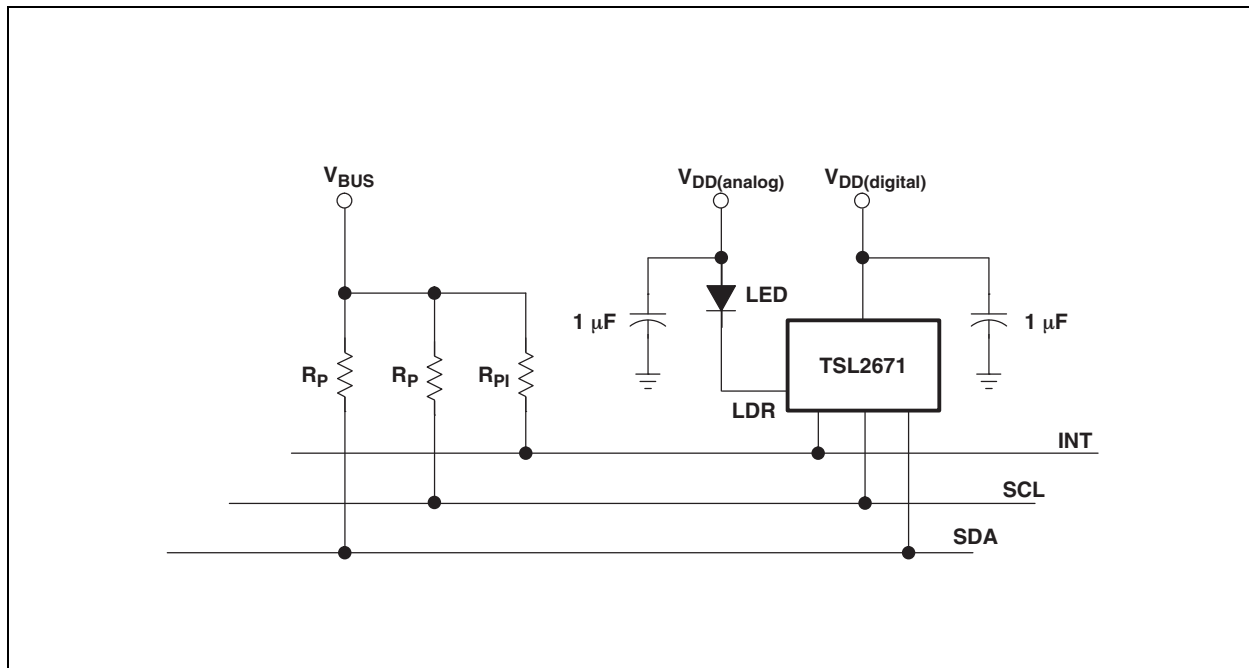

The power supply connection — PCB routing and supply decoupling — has a significant effect on proximity performance. Contact **ams** or see the application notes available at www.ams.com for power supply guidance.

If the hardware application requires more than 100 mA of current to drive the LED, then an external transistor should be used. Note, R2 should be sized adequately to bias the gate voltage given the LDR current mode setting. See [Figure 38](#).

Figure 38:
Application Hardware Circuit for Proximity Sensing with External LED Driver Using P-FET Transistor

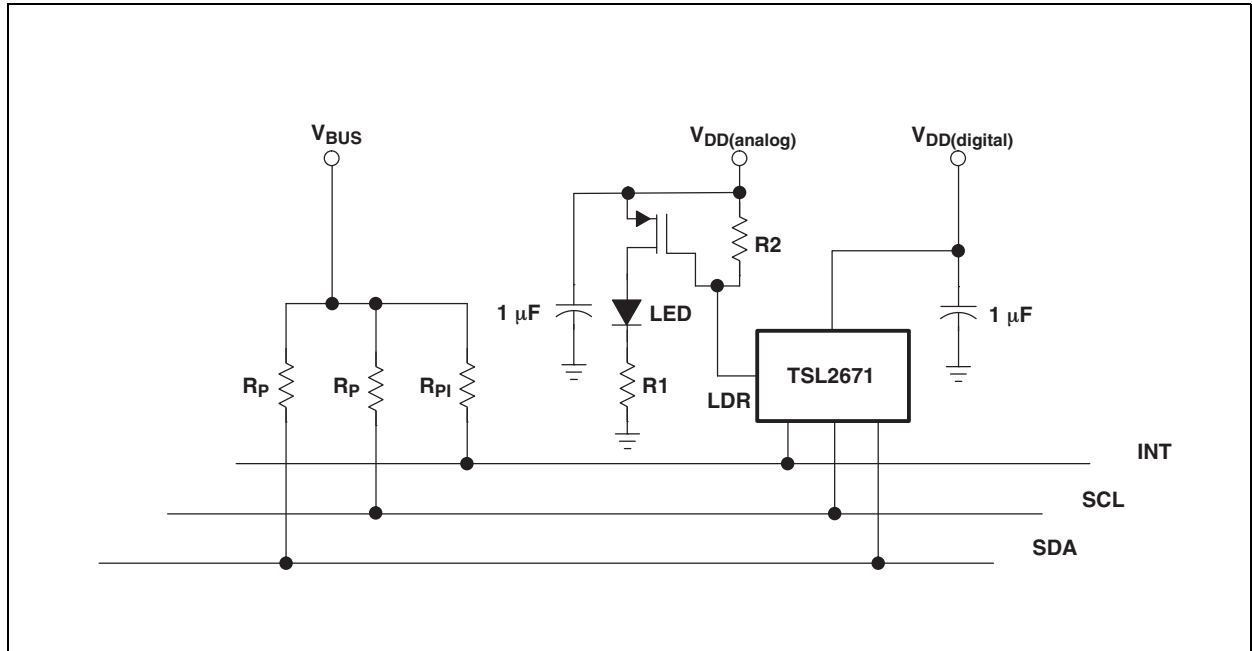

PCB Pad Layout

Suggested PCB pad layout guidelines for the Dual Flat No-Lead (FN) surface mount package are shown in [Figure 39](#).

Figure 39:
Suggested FN Package PCB Layout

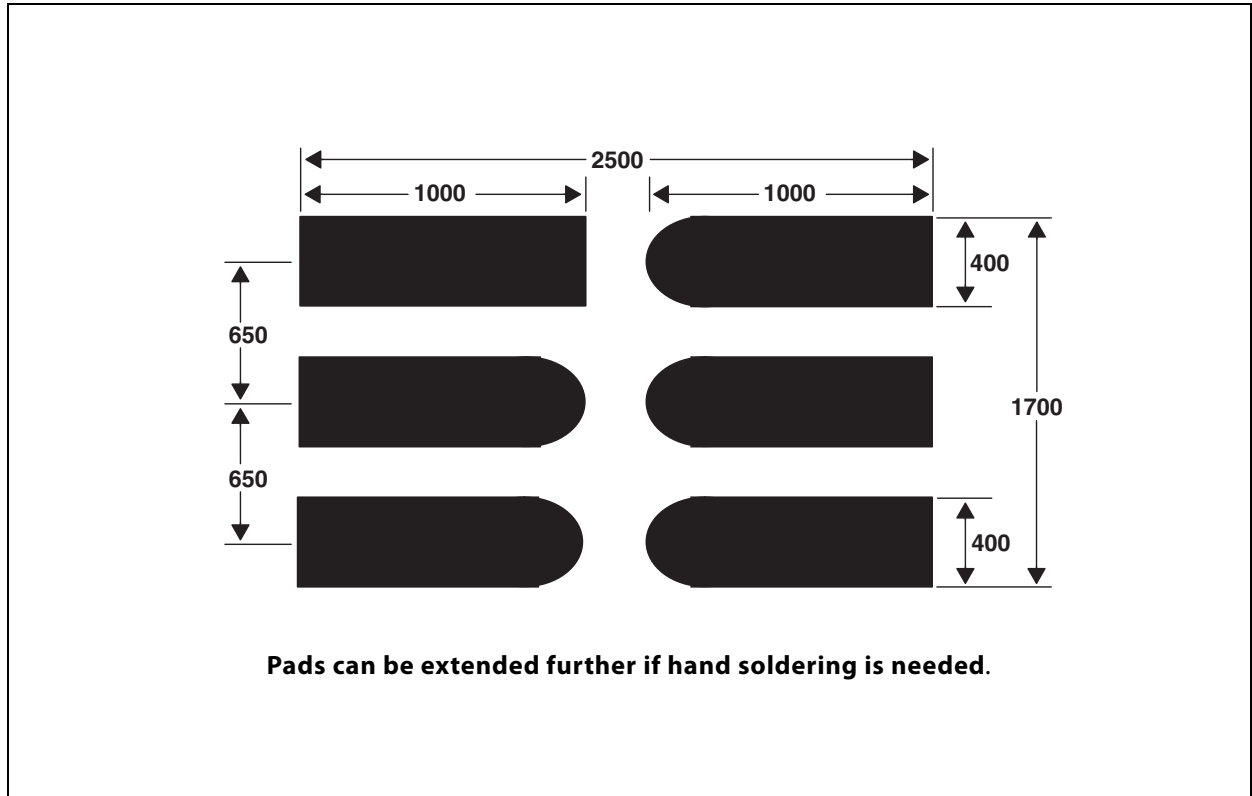

Note(s):

1. All linear dimensions are in micrometers.
2. This drawing is subject to change without notice.

Mechanical Data

Figure 40:
Package FN — Dual Flat No-Lead Packaging Configuration

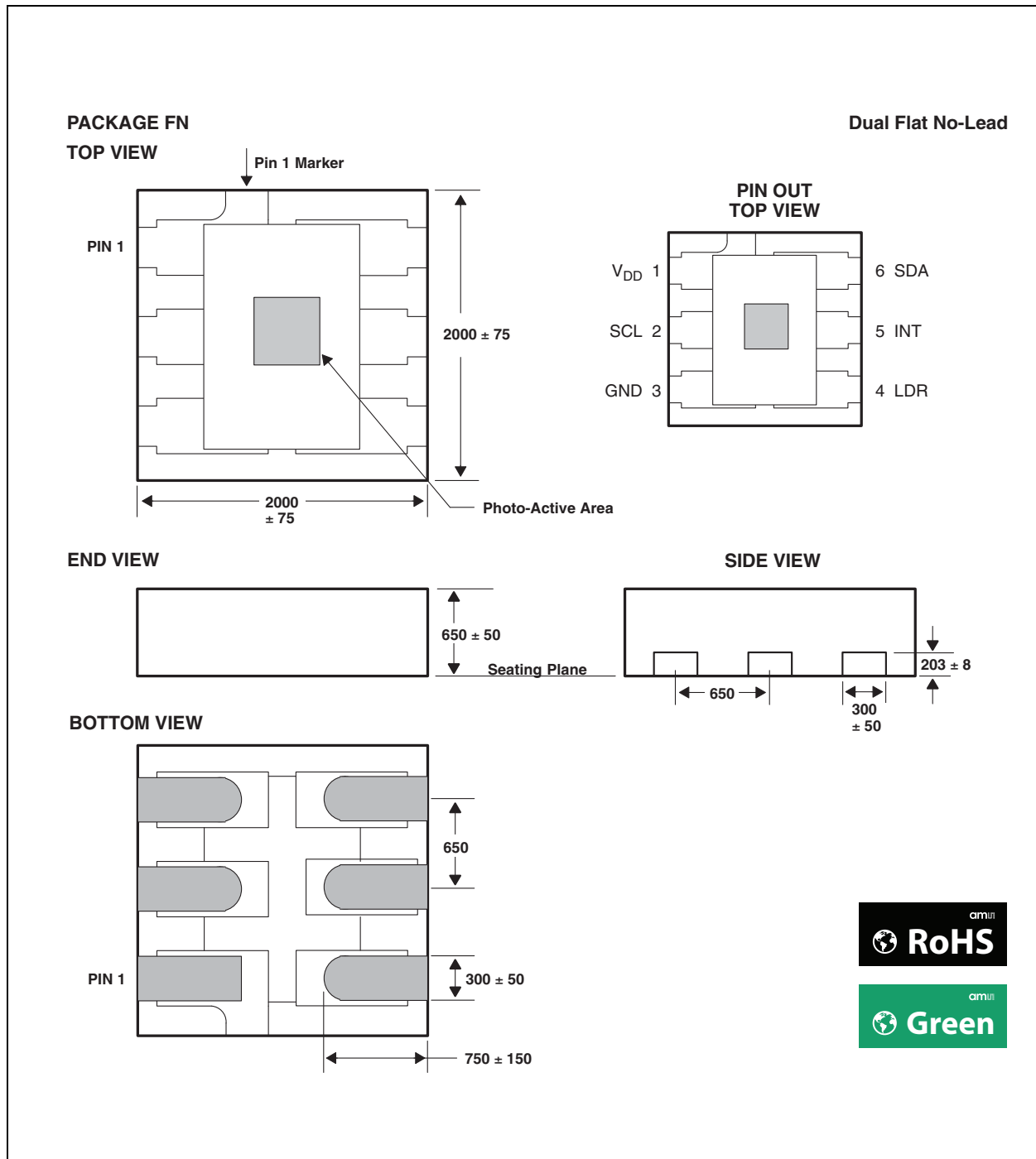

Note(s):

1. All linear dimensions are in micrometers. Dimension tolerance is ±20 µm unless otherwise noted.
2. The photodiode active area is 466 µm square and its center is 140 µm above and 20 µm to the right of the package center. The die placement tolerance is ± 75 µm in any direction.
3. Package top surface is molded with an electrically nonconductive clear plastic compound having an index of refraction of 1.55.
4. Contact finish is copper alloy A194 with pre-plated NiPdAu lead finish.
5. This package contains no lead (Pb).
6. This drawing is subject to change without notice.

Mechanical Data

Figure 41:
Package FN Carrier Tape

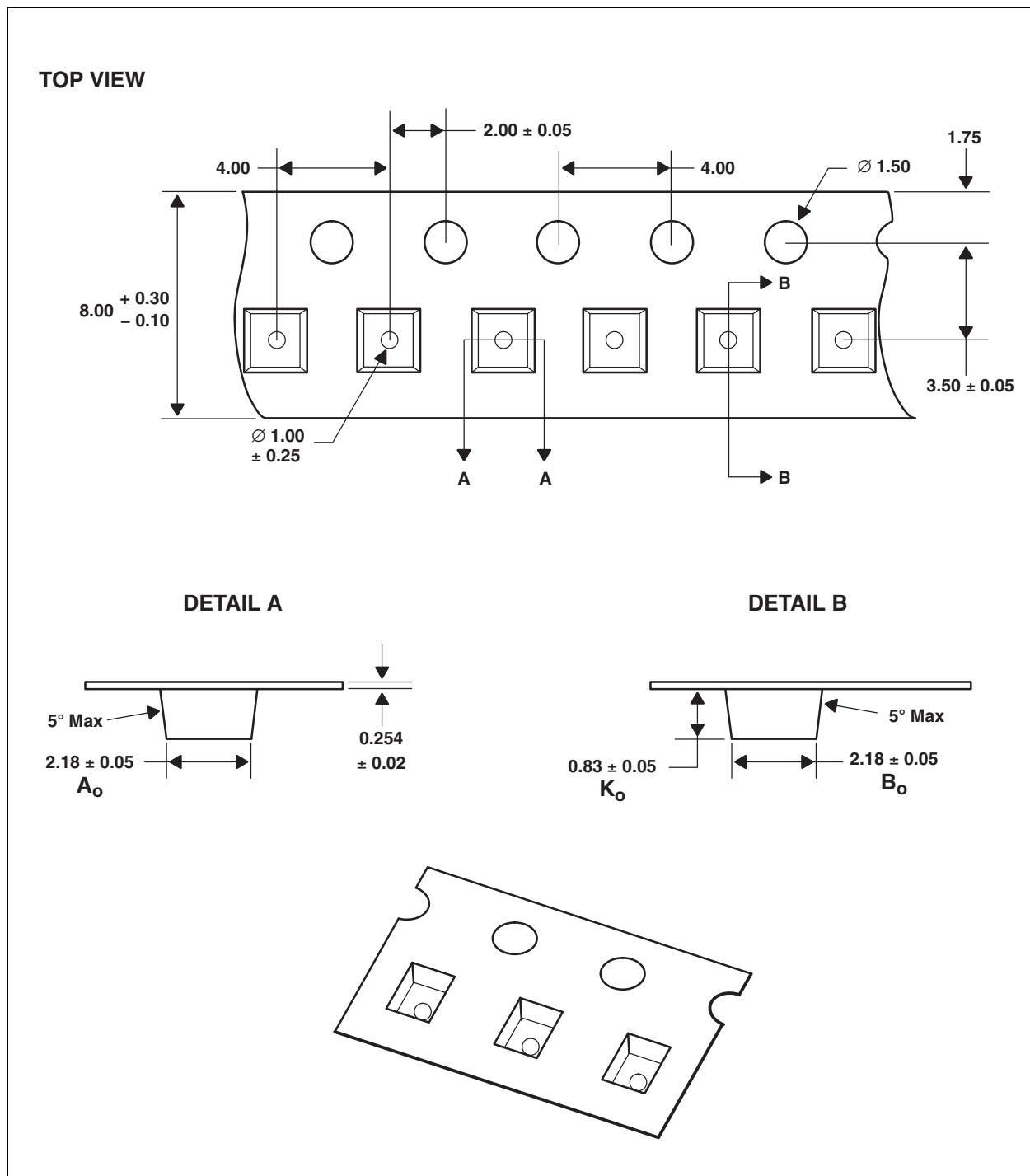

Note(s):

1. All linear dimensions are in millimeters. Dimension tolerance is ± 0.10 mm unless otherwise noted.
2. The dimensions on this drawing are for illustrative purposes only. Dimensions of an actual carrier may vary slightly.
3. Symbols on drawing A_o , B_o , and K_o are defined in ANSI EIA Standard 481-B 2001.
4. Each reel is 178 millimeters in diameter and contains 3500 parts.
5. **ams** packaging tape and reel conform to the requirements of EIA Standard 481-B.
6. In accordance with EIA standard, device pin 1 is located next to the sprocket holes in the tape.
7. This drawing is subject to change without notice.

Manufacturing Information

Soldering Information

The FN package has been tested and has demonstrated an ability to be reflow soldered to a PCB substrate. The process, equipment, and materials used in these test are detailed below.

The solder reflow profile describes the expected maximum heat exposure of components during the solder reflow process of product on a PCB. Temperature is measured on top of component. The components should be limited to a maximum of three passes through this solder reflow profile.

Figure 42:
Solder Reflow Profile

Parameter	Reference	Device
Average temperature gradient in preheating		2.5°C/s
Soak time	t_{soak}	2 to 3 minutes
Time above 217°C (T_1)	t_1	Max 60 s
Time above 230°C (T_2)	t_2	Max 50 s
Time above $T_{peak} - 10^\circ\text{C}$ (T_3)	t_3	Max 10 s
Peak temperature in reflow	T_{peak}	260°C
Temperature gradient in cooling		Max -5°C/s

Figure 43:
Solder Reflow Profile Graph

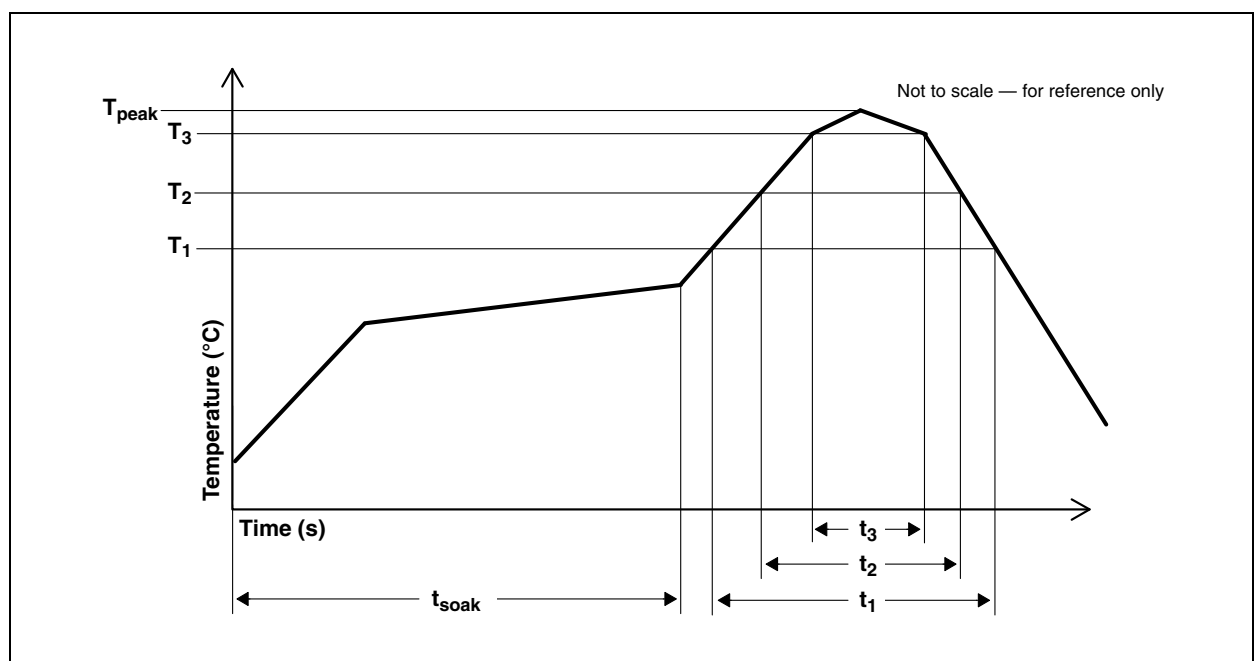

Storage Information

Moisture Sensitivity

Optical characteristics of the device can be adversely affected during the soldering process by the release and vaporization of moisture that has been previously absorbed into the package. To ensure the package contains the smallest amount of absorbed moisture possible, each device is dry-baked prior to being packed for shipping.

Devices are packed in a sealed aluminized envelope called a moisture barrier bag with silica gel to protect them from ambient moisture during shipping, handling, and storage before use.

The Moisture Barrier Bags should be stored under the following conditions:

- Temperature Range: < 40°C
- Relative Humidity: < 90%
- Total Time: No longer than 12 months from the date code on the aluminized envelope if unopened.

Rebaking of the reel will be required if the devices have been stored unopened for more than 12 months and the Humidity Indicator Card shows the parts to be out of the allowable moisture region.

Opened reels should be used within 168 hours if exposed to the following conditions:

- Temperature Range: < 30°C
- Relative Humidity: < 60%

If rebaking is required, it should be done at 50°C for 12 hours.

The FN package has been assigned a moisture sensitivity level of MSL 3.

Ordering & Contact Information

Figure 44:
Ordering Information

Ordering Code	Interface Description	Address	Package - Leads	Device
TSL26711FN	I ² C Vbus = V _{DD} Interface	0x39	FN-6	TSL26711
TSL26713FN	I ² C Vbus = 1.8 V Interface	0x39	FN-6	TSL26713
TSL26715FN	I ² C Vbus = V _{DD} Interface	0x29	FN-6	TSL26715 ⁽¹⁾
TSL26717FN	I ² C Vbus = 1.8 V Interface	0x29	FN-6	TSL26717 ⁽¹⁾

Note(s):

1. Contact **ams** for availability.

Buy our products or get free samples online at:

www.ams.com/ICdirect

Technical Support is available at:

www.ams.com/Technical-Support

Provide feedback about this document at:

www.ams.com/Document-Feedback

For further information and requests, e-mail us at:

ams_sales@ams.com

For sales offices, distributors and representatives, please visit:

www.ams.com/contact

Headquarters

ams AG
Tobelbader Strasse 30
8141 Premstaetten
Austria, Europe

Tel: +43 (0) 3136 500 0

Website: www.ams.com

RoHS Compliant & ams Green Statement

RoHS: The term RoHS compliant means that ams AG products fully comply with current RoHS directives. Our semiconductor products do not contain any chemicals for all 6 substance categories, including the requirement that lead not exceed 0.1% by weight in homogeneous materials. Where designed to be soldered at high temperatures, RoHS compliant products are suitable for use in specified lead-free processes.

ams Green (RoHS compliant and no Sb/Br): ams Green defines that in addition to RoHS compliance, our products are free of Bromine (Br) and Antimony (Sb) based flame retardants (Br or Sb do not exceed 0.1% by weight in homogeneous material).

Important Information: The information provided in this statement represents ams AG knowledge and belief as of the date that it is provided. ams AG bases its knowledge and belief on information provided by third parties, and makes no representation or warranty as to the accuracy of such information. Efforts are underway to better integrate information from third parties. ams AG has taken and continues to take reasonable steps to provide representative and accurate information but may not have conducted destructive testing or chemical analysis on incoming materials and chemicals. ams AG and ams AG suppliers consider certain information to be proprietary, and thus CAS numbers and other limited information may not be available for release.

Copyrights & Disclaimer

Copyright ams AG, Tobelbader Strasse 30, 8141 Premstaetten, Austria-Europe. Trademarks Registered. All rights reserved. The material herein may not be reproduced, adapted, merged, translated, stored, or used without the prior written consent of the copyright owner.

Devices sold by ams AG are covered by the warranty and patent indemnification provisions appearing in its General Terms of Trade. ams AG makes no warranty, express, statutory, implied, or by description regarding the information set forth herein. ams AG reserves the right to change specifications and prices at any time and without notice. Therefore, prior to designing this product into a system, it is necessary to check with ams AG for current information. This product is intended for use in commercial applications. Applications requiring extended temperature range, unusual environmental requirements, or high reliability applications, such as military, medical life-support or life-sustaining equipment are specifically not recommended without additional processing by ams AG for each application. This product is provided by ams AG "AS IS" and any express or implied warranties, including, but not limited to the implied warranties of merchantability and fitness for a particular purpose are disclaimed.

ams AG shall not be liable to recipient or any third party for any damages, including but not limited to personal injury, property damage, loss of profits, loss of use, interruption of business or indirect, special, incidental or consequential damages, of any kind, in connection with or arising out of the furnishing, performance or use of the technical data herein. No obligation or liability to recipient or any third party shall arise or flow out of ams AG rendering of technical or other services.

Document Status

Document Status	Product Status	Definition
Product Preview	Pre-Development	Information in this datasheet is based on product ideas in the planning phase of development. All specifications are design goals without any warranty and are subject to change without notice
Preliminary Datasheet	Pre-Production	Information in this datasheet is based on products in the design, validation or qualification phase of development. The performance and parameters shown in this document are preliminary without any warranty and are subject to change without notice
Datasheet	Production	Information in this datasheet is based on products in ramp-up to full production or full production which conform to specifications in accordance with the terms of ams AG standard warranty as given in the General Terms of Trade
Datasheet (discontinued)	Discontinued	Information in this datasheet is based on products which conform to specifications in accordance with the terms of ams AG standard warranty as given in the General Terms of Trade, but these products have been superseded and should not be used for new designs

Revision Information

Changes from 118 (2011-Jan) to current revision 1-00 (2016-Jul-12)	Page
Content of TAOS datasheet was updated to latest ams design	
Updated Key Benefits & Features section	2
Updated Figure 44	38

Note(s):

1. Page and figure numbers for the previous version may differ from page and figure numbers in the current revision.
2. Correction of typographical errors is not explicitly mentioned.

Content Guide

1	General Description
2	Key Benefits & Features
2	Applications
3	Functional Block Diagram
4	Detailed Description
5	Pin Assignments
6	Absolute Maximum Ratings
7	Operating Characteristics
8	Proximity Characteristics
8	Wait Characteristics
9	AC Electrical Characteristics
10	Parameter Measurement Information
11	Typical Characteristics
13	Principles of Operation
13	System State Machine
14	Proximity Detection
17	Interrupts
18	State Diagram
19	Power Management
20	I ² C Protocol
22	Register Description
22	Register Set
23	Command Register
24	Enable Register (0x00)
24	Proximity Time Control Register (0x02)
25	Wait Time Register (0x03)
25	Proximity Interrupt Threshold Registers (0x08 - 0x0B)
26	Persistence Register (0x0C)
27	Configuration Register (0x0D)
27	Proximity Pulse Count Register (0x0E)
28	Control Register (0x0F)
29	ID Register (0x12)
29	Status Register (0x13)
30	Proximity Data Registers (0x18 - 0x19h)
31	Application Information: Hardware
31	LED Driver Pin with Proximity Detection
33	PCB Pad Layout
34	Mechanical Data
35	Mechanical Data
36	Manufacturing Information
36	Soldering Information
37	Storage Information
37	Moisture Sensitivity
38	Ordering & Contact Information
39	RoHS Compliant & ams Green Statement

- 40 Copyrights & Disclaimer**
- 41 Document Status**
- 42 Revision Information**

Mouser Electronics

Authorized Distributor

Click to View Pricing, Inventory, Delivery & Lifecycle Information:

[ams OSRAM:](#)

[TSL26711FN](#) [TSL26713FN](#)