

67023 4N51, 4N52 RED HERMETIC NUMERIC DISPLAYS



05/26/2009

Features:

- Conforms to MIL-PRF-19500/708
- Commercial, JAN and JANTX versions available
- 4 X 7 dot matrix character
- Memory latch/decoder/driver is TTL compatible
- Categorized for luminous intensity

Applications:

- High reliability systems
- Instrumentation panels
- Communication equipment
- Medical equipment
- Harsh environments

DESCRIPTION

The **4N51** and **4N52** are solid state numeric displays for use in high reliability applications. The displays feature an on-board decoder/driver and memory. These displays are hermetically sealed and conform to MIL-PRF-19500/708, the general specification for light emitting diode displays. The character height is 0.290" (7.37mm).

The 4N51 is a numeric display which decodes positive BCD logic into the numbers "0-9", a "-" sign, a right-hand decimal point, and a test pattern (all LED's on).

The 4N52 is the same as the 4N51, but the decimal point is located on the left side of the device.

ABSOLUTE MAXIMUM RATINGS

Supply Voltage	-0.5 V to 7 V
Voltage Applied to Input Logic, DP and Enable Pins.....	-0.5 V to 7 V
Storage Temperature.....	-65°C to +125°C
Operating Free-Air Temperature Range.....	-55°C to +100°C
Lead Solder Temperature (5 seconds, 1/16" below seating plane).....	260°C
Total Power Dissipation (Note 1).....	.935 mW

Notes:

1. VCC = 5.5 V, numeral 5 and decimal point lighted.

67023 4N51, 4N52

05/26/2009

RED HERMETIC NUMERIC DISPLAYS

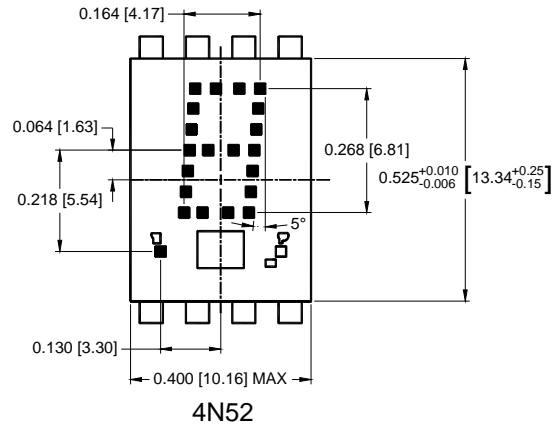
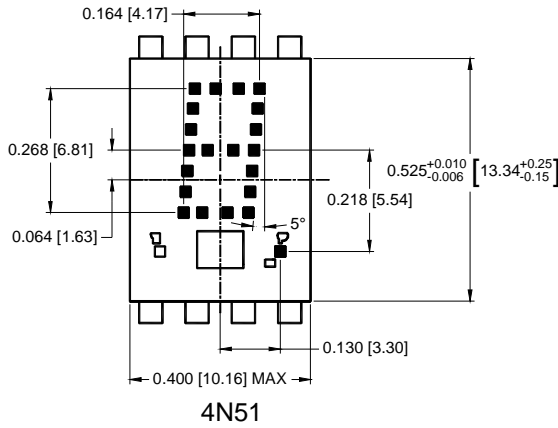

ALL TOLERANCES ARE ± 0.008 [0.20] UNLESS OTHERWISE SPECIFIED

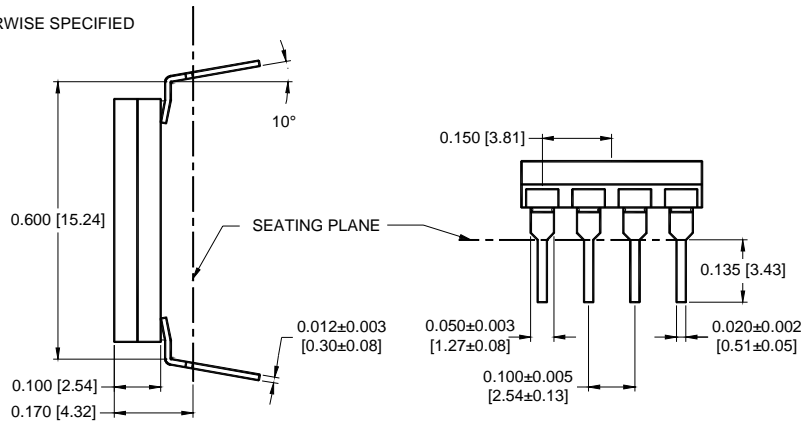
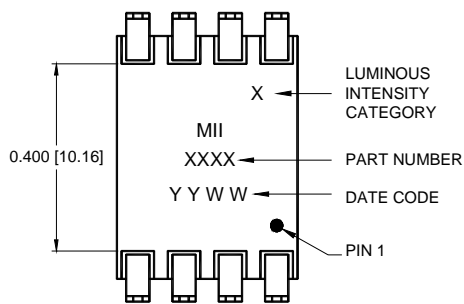

ALL TOLERANCES ARE ± 0.015 UNLESS OTHERWISE SPECIFIED

ALL DIMENSIONS ARE IN INCHES [MILLIMETERS].

ELECTRICAL OPTICAL CHARACTERISTICS

T_A = -55°C to +100°C unless otherwise specified.

PARAMETER	SYMBOL	MIN	TYP	MAX	UNITS	TEST CONDITIONS	NOTE
Supply Current	I _{CC}		112	160	mA	V _{CC} = 5.5V Numeral 5 and DP lighted	1
Power Dissipation	P _T		560	935	mW	V _{CC} = 5.5V Numeral 5 and DP lighted	1
Luminous Intensity per LED	I _V	40	85		μcd	V _{CC} = 5V, T _A = 25°C	
Logic Low-Level Input Current	I _{IL}			-1.5	mA	V _{CC} = 5.5V, V _{IL} = 0.4V	
Logic High-Level Input Current	I _{IH}			50	μA	V _{CC} = 5.5V, V _{IH} = 2.4V	
Enable Low-Level Input Current	I _{EL}			-1.5	mA	V _{CC} = 5.5V, V _{EL} = 0.4V	
Enable High-Level Input Current	I _{EH}			50	μA	V _{CC} = 5.5V, V _{EH} = 2.4V	
Wavelength at Peak Emission	λ _P		655		nm	T _A = 25°C	1
Dominant Wavelength	d		640			T _A = 25°C	1, 2
Weight			1		gm		

NOTES:

- All typical values at V_{CC} = 5.0 volts, t_A = 25°C.
- The dominant wavelength, λ_d is a single wavelength that defines the saturated color of monochromatic light, as derived from the CIE chromaticity diagram.

4N51

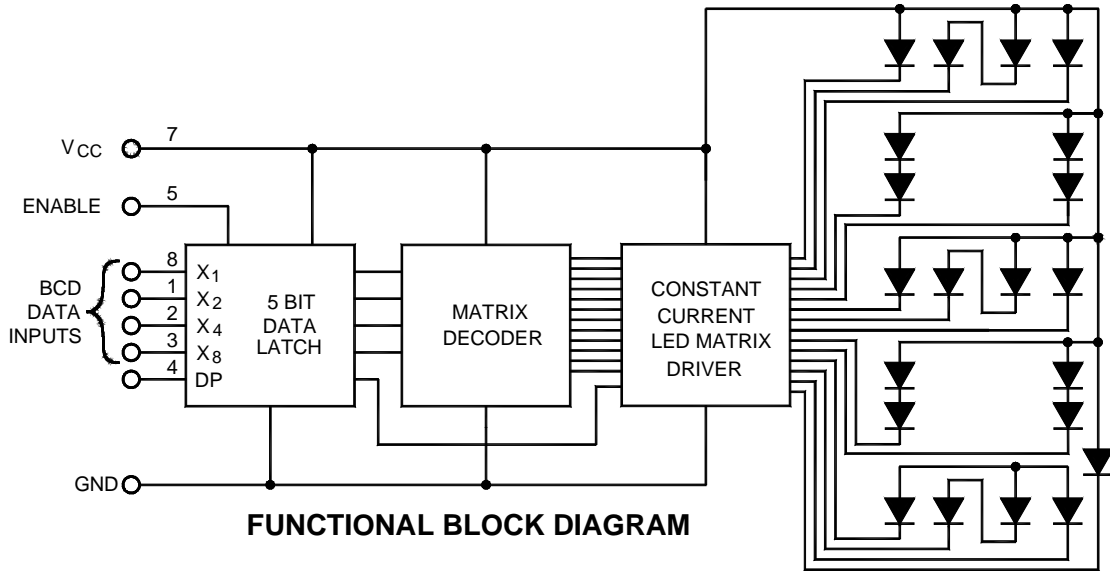

FUNCTIONAL BLOCK DIAGRAM

TERMINAL CONNECTIONS

PIN	FUNCTION
	4N51
1	INPUT 2
2	INPUT 4
3	INPUT 8
4	DECIMAL POINT
5	LATCH ENABLE
6	GROUND
7	V _{cc}
8	INPUT 1

TRUTH TABLE				
BCD DATA				4N51
X8	X4	X2	X1	
L	L	L	L	0
L	L	L	H	1
L	L	H	L	2
L	L	H	H	3
L	H	L	L	4
L	H	L	H	5
L	H	H	L	6
L	H	H	H	7
H	L	L	L	8
H	L	L	H	9
H	L	H	L	A
H	L	H	H	BLANK
H	H	L	L	BLANK
H	H	L	H
H	H	H	L	BLANK
H	H	H	H	BLANK
DECIMAL PT.				ON V _{DP} - L
				OFF V _{DP} - H
ENABLE				LOAD DATA V _E - L
				LATCH DATA V _E - H

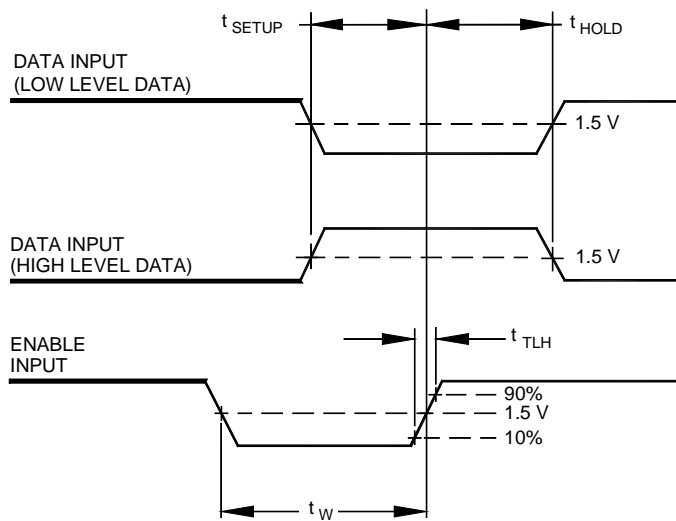

TIMING DIAGRAM

4N52

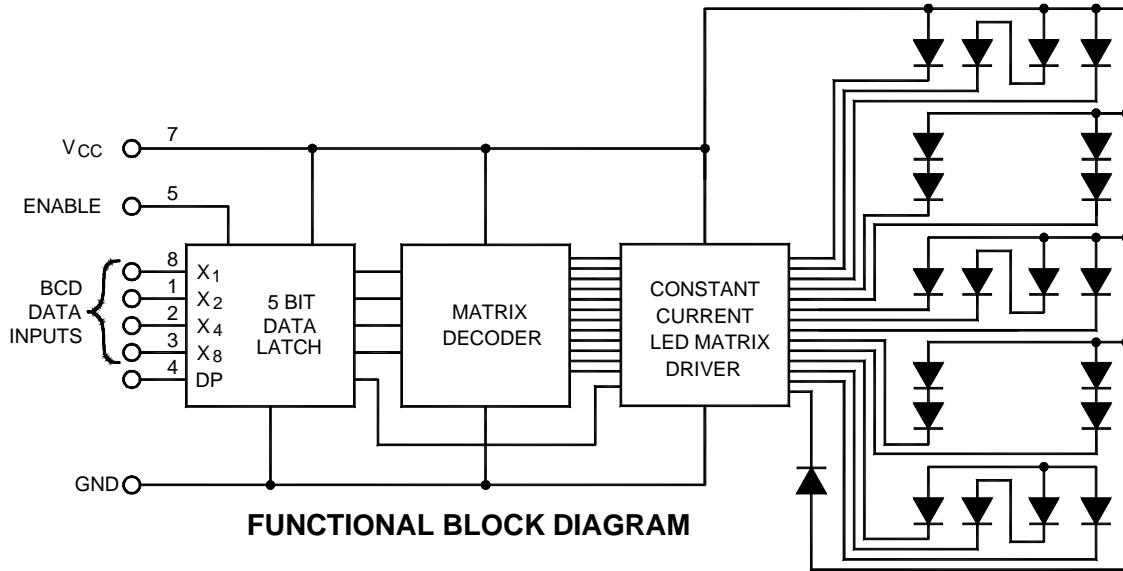

TERMINAL CONNECTIONS

PIN	FUNCTION
	4N52
1	INPUT 2
2	INPUT 4
3	INPUT 8
4	DECIMAL POINT
5	LATCH ENABLE
6	GROUND
7	Vcc
8	INPUT 1

TRUTH TABLE				
BCD DATA				4N52
X8	X4	X2	X1	
L	L	L	L	0
L	L	L	H	1
L	L	H	L	2
L	L	H	H	3
L	H	L	L	4
L	H	L	H	5
L	H	H	L	6
L	H	H	H	7
H	L	L	L	8
H	L	L	H	9
H	L	H	L	8
H	L	H	H	BLANK
H	H	L	L	BLANK
H	H	L	H
H	H	H	L	BLANK
H	H	H	H	BLANK
DECIMAL POINT				DISPLAY ON $V_{DP} - L$
				DISPLAY OFF $V_{DP} - H$
ENABLE				LOAD DATA $V_E - L$
				LATCH DATA $V_E - H$

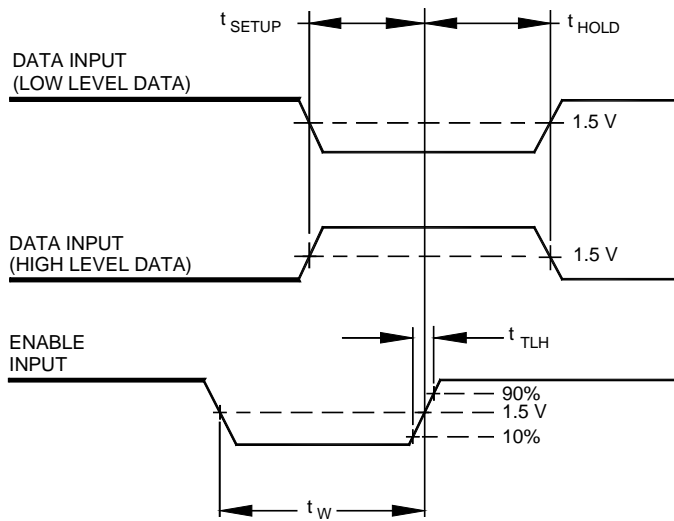

TIMING DIAGRAM

RECOMMENDED OPERATING CONDITIONS:

PARAMETER	SYMBOL	MIN	MAX	UNITS
Supply Voltage	V_{CC}	4.5	5.5	V
Operating Temperature	T_A	-55	100	°C
Enable Pulse Width	t_W	100		ns
Time data must be held before positive transition of enable line	t_{SETUP}	50		ns
Time data must be held after positive transition of enable line	t_{HOLD}	50		ns
Enable pulse rise time	t_{TLH}		200	ns

SELECTION GUIDE

PART NUMBER	PART DESCRIPTION
67023-001	4N51 Commercial
67023-011	JAN4N51XX
67023-101	JANTX4N51XX
67023-002	4N52 Commercial
67023-012	JAN4N52XX
67023-102	JANTX4N52XX

Luminous intensity code

LUMINOUS INTENSITY CODE	MINIMUM LUMINOUS INTENSITY	MAXIMUM LUMINOUS INTENSITY
	μcd	μcd
D	59	106
E	79	142
F	106	190
G	142	255
H	190	342
I	257	462
J	343	617
K	457	820

The first X in the DSCC Part number is intensity code. Where a luminous intensity code is required, it must be specified in the contract or order. (Due to the overlapping of the luminous intensity codes, it is recommended that the two adjacent categories be specified).

The second X in the DSCC Part number is the lead finish code.

FINISH LETTER	LEAD FINISH
A	Hot solder dip
C	Gold plate