

54VHC/74VHC04 • 54VHCT/74VHCT04 Hex Inverter

General Description

The 74VHC/VHCT04 is an advanced high speed CMOS INVERTER fabricated with silicon gate CMOS technology. It achieves the high speed operation similar to equivalent Bipolar Schottky TTL while maintaining the CMOS low power dissipation.

The internal circuit is composed of 3 stages including buffer output, which provide high noise immunity and stable output. An input protection circuit ensures that 0V-7V can be applied to the input pins without regard to the supply voltage. This device can be used to interface 5V to 3V systems and two supply systems such as battery back up. This circuit prevents device destruction due to mismatched supply and input voltages.

NOTE:
MILITARY SPECIFICATIONS ARE PRELIMINARY

Features

- High speed:
 - VHC $t_{PD} = 3.8 \text{ ns (typ) @ } V_{CC} = 5\text{V}$
 - VHCT $t_{PD} = 4.7 \text{ ns (typ) @ } V_{CC} = 5\text{V}$
- High noise immunity:
 - VHC $V_{NIH} = V_{NIL} = 28\% V_{CC} \text{ (Min)}$
 - VHCT $V_{IH} = 2.0\text{V}, V_{IL} = 0.8\text{V}$
- Operating Voltage:
 - VHC $V_{CC} \text{ (opr)} = 2.0\text{V} \sim 5.5\text{V}$
 - VHCT $V_{CC} \text{ (opr)} = 4.5\text{V} \sim 5.5\text{V}$
- Power down protection:
 - VHC inputs only
 - VHCT inputs and outputs
- Low Noise:
 - VHC $V_{OLP} = 0.4\text{V (typ)}$
 - VHCT $V_{OLP} = 0.8\text{V (typ)}$
- Low power dissipation:
 - $I_{CC} = 2 \mu\text{A (Max) @ } T_A = 25^\circ\text{C}$
- Balanced propagation delays: $t_{PLH} \approx t_{PHL}$
- Pin and function compatible with 74HC/HCT04

Logic Symbol

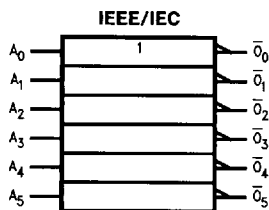

TL/F/11516-1

Connection Diagrams

Pin Assignment for
DIP, Flatpak, SSOP, TSSOP and SOIC

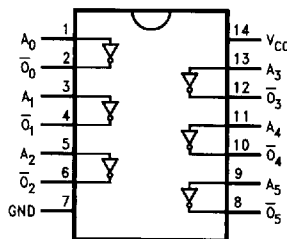

TL/F/11516-2

Pin Assignment
for LCC

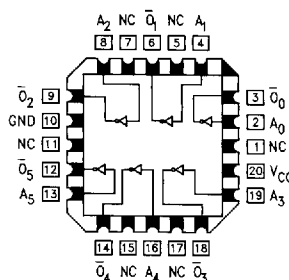

TL/F/11516-3

Pin Names	Description
A_n	Inputs
\bar{O}_n	Outputs

Truth Table

A	O
L	H
H	L

54VHC/74VHC04 • 54VHCT/74VHCT04 Hex Inverter

Absolute Maximum Ratings (Note 1)

If Military/Aerospace specified devices are required, please contact the National Semiconductor Sales Office/Distributors for availability and specifications.

Supply Voltage (V_{CC})	-0.5V to +7.0V
DC Input Voltage (V_{IN})	-0.5V to +7.0V
DC Output Voltage (V_{OUT})	
VHC	-0.5V to $V_{CC} + 0.5V$
VHCT*	-0.5V to 7.0V
Input Diode Current (I_{IK})	-20 mA
Output Diode Current (I_{OK})	
VHC	± 20 mA
VHCT	-20 mA
DC Output Current (I_{OUT})	± 25 mA
DC V_{CC} /GND Current (I_{CC})	± 50 mA
Storage Temperature (T_{STG})	-65°C to +150°C
Lead Temperature (T_L) (Soldering, 10 seconds)	300°C

* $V_{OUT} > V_{CC}$ only if output is in H state.

Note 1: Absolute Maximum Ratings are values beyond which the device may be damaged or have its useful life impaired. The databook specifications should be met, without exception, to ensure that the system design is reliable over its power supply, temperature, and output/input loading variables. National does not recommend operation outside databook specifications.

Recommended Operating Conditions

Supply Voltage (V_{CC})	
VHC	2.0V to +5.5V
VHCT	4.5V to +5.5V
Input Voltage (V_{IN})	0V to +5.5V
Output Voltage (V_{OUT})	0V to V_{CC}
Operating Temperature (T_{OPR})	
54VHC/VHCT	-55°C to +125°C
74VHC/VHCT	-40°C to +85°C
Input Rise and Fall Time (t_r, t_f)	
$V_{CC} = 3.3V \pm 0.3V$ (VHC only)	0 ~ 100 ns/V
$V_{CC} = 5.0V \pm 0.5V$	0 ~ 20 ns/V

DC Characteristics for 'VHC Family Devices

Symbol	Parameter	V_{CC} (V)	74VHC		54VHC		74VHC		Units	Conditions	
			$T_A = 25^\circ C$			$T_A = -55^\circ C$ to +125°C		$T_A = -40^\circ C$ to +85°C			
			Min	Typ	Max	Min	Max	Min			Max
V_{IH}	High Level Input Voltage	2.0 3.0-5.5	1.50		1.50	0.7 V_{CC}	1.50	0.7 V_{CC}	V		
V_{IL}	Low Level Input Voltage	2.0 3.0-5.5		0.50		0.50	0.3 V_{CC}	0.50	0.3 V_{CC}	V	
V_{OH}	High Level Output Voltage	2.0	1.9	2.0	1.9		1.9		V	$V_{IN} = V_{IH}$ or V_{IL}	$I_{OH} = -50 \mu A$
		3.0	2.9	3.0	2.9		2.9				
V_{OH}	High Level Output Voltage	4.5	4.4	4.5	4.4		4.4		V	$V_{IN} = V_{IH}$ or V_{IL}	$I_{OH} = -4$ mA $I_{OH} = -8$ mA
		3.0	2.58		2.4		2.48				
V_{OL}	Low Level Output Voltage	2.0		0.0	0.1		0.1	0.1	V	$V_{IN} = V_{IH}$ or V_{IL}	$I_{OL} = +50 \mu A$
		3.0		0.0	0.1		0.1	0.1			
V_{OL}	Low Level Output Voltage	4.5		0.0	0.1		0.1	0.1	V	$V_{IN} = V_{IH}$ or V_{IL}	$I_{OL} = 4$ mA $I_{OL} = 8$ mA
		3.0			0.36		0.50	0.44			
		4.5			0.36		0.50	0.44			
I_{IN}	Input Leakage Current	0-5.5			± 0.1		± 1.0	± 1.0	μA	$V_{IN} = 5.5V$ or GND	
I_{CC}	Quiescent Supply Current	5.5			2.0		40.0	20.0	μA	$V_{IN} = V_{CC}$ or GND	

DC Characteristics for 'VHC Family Devices

Symbol	Parameter	V _{CC} (V)	74VHC		54VHC	74VHC	Units	Conditions
			T _A = 25°C		T _A = -55°C to +125°C	T _A = -40°C to +85°C		
			Typ	Limits	Limits	Limits		
**V _{OLP}	Quiet Output Maximum Dynamic V _{OL}	5.0	0.4	0.8			V	C _L = 50 pF
**V _{OLV}	Quiet Output Minimum Dynamic V _{OL}	5.0	-0.4	-0.8			V	C _L = 50 pF
**V _{IHD}	Minimum High Level Dynamic Input Voltage	5.0		3.5			V	C _L = 50 pF
**V _{ILD}	Maximum Low Level Dynamic Input Voltage	5.0		1.5			V	C _L = 50 pF

**Parameter guaranteed by design.

DC Characteristics for 'VHCT Family Devices

Symbol	Parameter	V _{CC} (V)	74VHCT			54VHCT	74VHCT	Units	Conditions			
			T _A = 25°C			T _A = -55°C to +125°C					T _A = -40°C to +85°C	
			Min	Typ	Max	Min	Max				Min	Max
V _{IH}	High Level Input Voltage	4.5 5.5	2.0 2.0				2.0 2.0	V				
V _{IL}	Low Level Input Voltage	4.5 5.5		0.8 0.8			0.8 0.8	V				
V _{OH}	High Level Output Voltage	4.5	3.15	3.65			3.15	V	V _{IN} = V _{IH} or V _{IL}	I _{OH} = -50 μA		
			2.5				2.4	V		I _{OH} = -8 mA		
V _{OL}	Low Level Output Voltage	4.5		0.0	0.1		0.1	V	V _{IN} = V _{IH} or V _{IL}	I _{OL} = 50 μA		
					0.36		0.44	V		I _{OL} = 8 mA		
I _{IN}	Input Leakage Current	0-5.5		±0.1			±1.0	μA	V _{IN} = 5.5V or GND			
I _{CC}	Quiescent Supply Current	5.5		2.0			20.0	μA	V _{IN} = V _{CC} or GND			
I _{CC(T)}	Maximum I _{CC} /Input	5.5		1.35			1.50	mA	V _{IN} = 3.4V Other Inputs = V _{CC} or GND			
I _{OPD}	Output Leakage Current (Power Down State)	0.0		+0.5			+5.0	μA	V _{OUT} = 5.5V			

DC Characteristics for 'VHCT Family Devices

Symbol	Parameter	V _{CC} (V)	74VHCT		54VHCT	74VHCT	Units	Conditions
			T _A = 25°C		T _A = -55°C to +125°C	T _A = -40°C to +85°C		
			Typ	Limits	Limits	Limits		
**V _{OLP}	Quiet Output Maximum Dynamic V _{OL}	5.0	0.8	1.0			V	C _L = 50 pF
**V _{OLV}	Quiet Output Minimum Dynamic V _{OL}	5.0	-0.8	1.0			V	C _L = 50 pF
**V _{IHD}	Minimum High Level Dynamic Input Voltage	5.0		2.0			V	C _L = 50 pF
**V _{ILD}	Maximum Low Level Dynamic Input Voltage	5.0		0.8			V	C _L = 50 pF

**Parameter guaranteed by design.

AC Electrical Characteristics for 'VHC Family Devices:

Symbol	Parameter	V _{CC} (V)	74VHC			54VHC		74VHC		Units	Conditions
			T _A = 25°C			T _A = -55°C to +125°C		T _A = -40°C to +85°C			
			Min	Typ	Max	Min	Max	Min	Max		
t _{PHL} , t _{PLH}	Propagation Delay	3.3 ± 0.3	5.0	7.1			1.0	8.5	ns	C _L = 15 pF	
					7.5	10.6				1.0	12.0
		5.0 ± 0.5	3.8	5.5			1.0	6.5	ns	C _L = 15 pF	
						5.3	7.5				1.0
C _{IN}	Input Capacitance		4	10				10	pF	V _{CC} = OPEN	
C _{PD}	Power Dissipation Capacitance		18						pF	(Note 1)	

Note 1: C_{PD} is defined as the value of the internal equivalent capacitance which is calculated from the operating current consumption without load. Average operating current can be obtained by the equation: I_{CC (opr.)} = C_{PD} * V_{CC} * f_{IN} + I_{CC}/6 (per gate)

AC Electrical Characteristics for 'VHCT Family Devices:

Symbol	Parameter	V _{CC} (V)	74VHCT			54VHCT		74VHCT		Units	Conditions
			T _A = 25°C			T _A = -55°C to +125°C		T _A = -40°C to +85°C			
			Min	Typ	Max	Min	Max	Min	Max		
t _{PHL} , t _{PLH}	Propagation Delay	5.0 ± 0.5	4.7	6.7			1.0	7.5	ns	C _L = 15 pF	
					5.5	7.7				1.0	8.5
C _{IN}	Input Capacitance		4	10				10	pF	V _{CC} = OPEN	
C _{PD}	Power Dissipation Capacitance		14						pF	(Note 1)	

Note 1: C_{PD} is defined as the value of the internal equivalent capacitance which is calculated from the operating current consumption without load. Average operating current can be obtained by the equation: I_{CC (opr.)} = C_{PD} * V_{CC} * f_{IN} + I_{CC}/6 (per gate).

Ordering Information

The device number is used to form part of a simplified purchasing code, where the package type and temperature range are defined as follows:

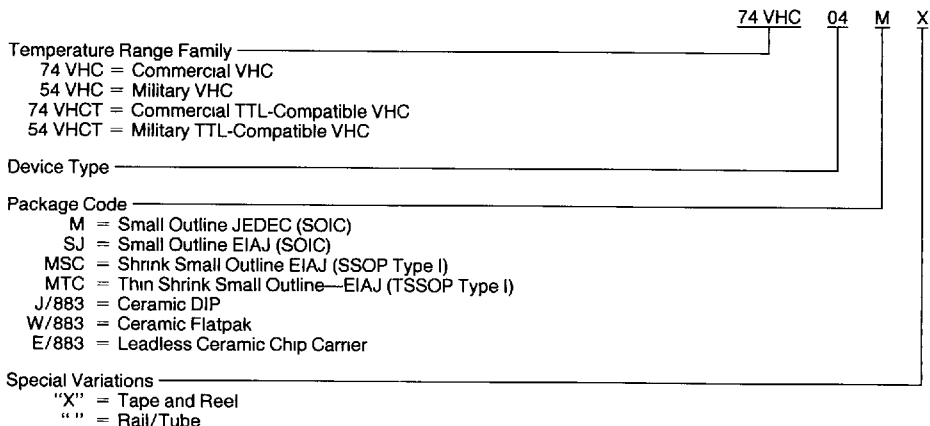

Physical Dimensions inches (millimeters)

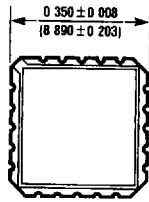

Top View

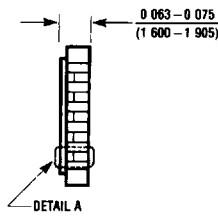

Side View

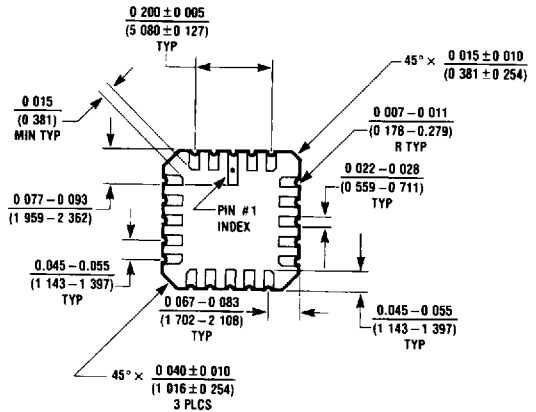

Bottom View

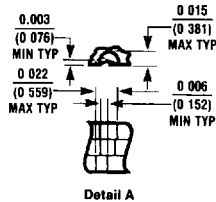

Detail A

20-Lead Ceramic Leadless Chip Carrier, Type C (L)
Order Number 54VHC04E/883 or 54VHCT04E/883
NS Package Number E20A

E20A (REV D)

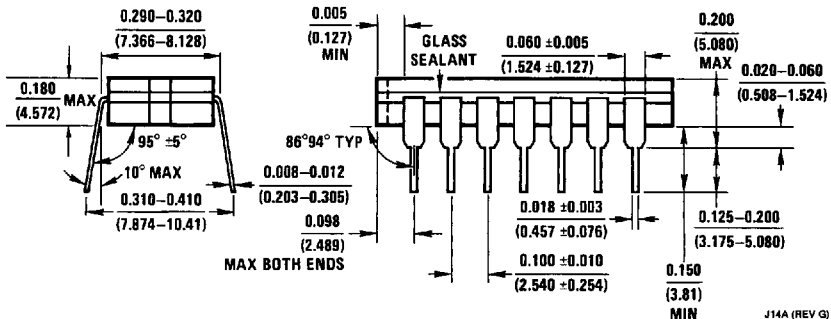
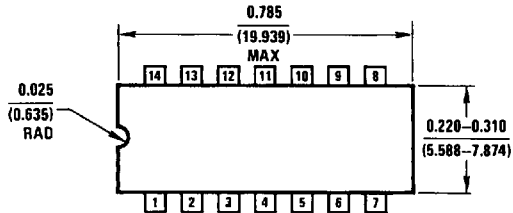

14-Lead Ceramic Dual-In-Line Package (D)
Order Number 54VHC04J/883 or 54VHCT04J/883
NS Package Number J14A

J14A (REV Q)

Physical Dimensions inches (millimeters) (Continued)

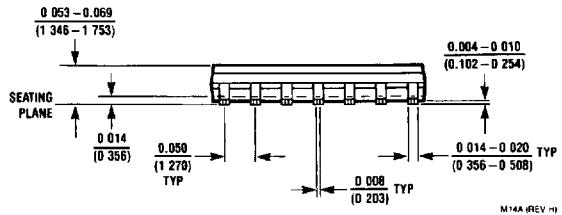
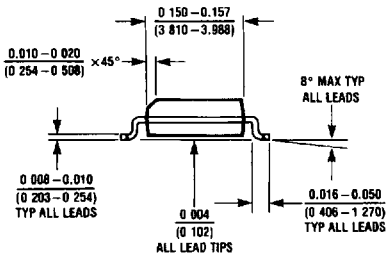
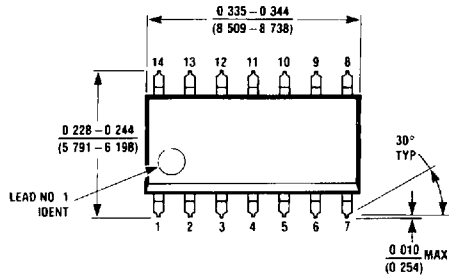

M14A (REV. 75)

14-Lead Small Outline Integrated Circuit JEDEC SOIC (M)
Order Number 74VHC04M, 74VHC04MX, 74VHCT04M or 74VHCT04MX
NS Package Number M14A

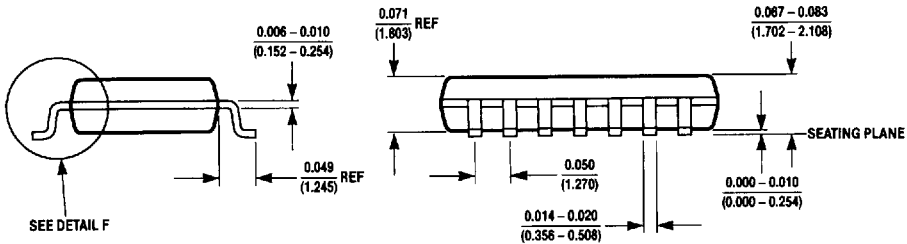
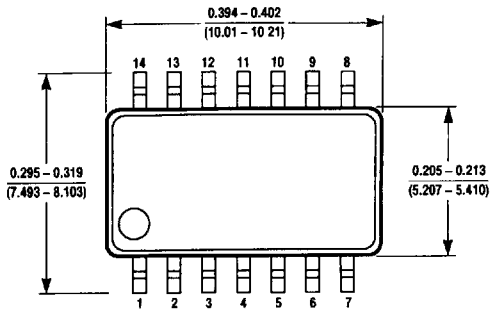
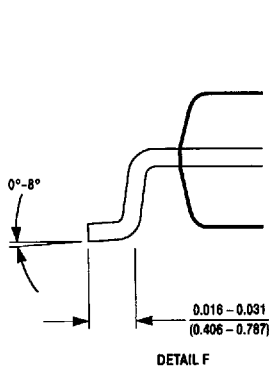

M14D (REV. A)

14-Lead Small Outline Package - EIAJ SOIC (SJ)
Order Number 74VHC04SJ, 74VHC04SJX, 74VHCT04SJ or 74VHCT04SJX
NS Package Number M14D

Physical Dimensions inches (millimeters) (Continued)

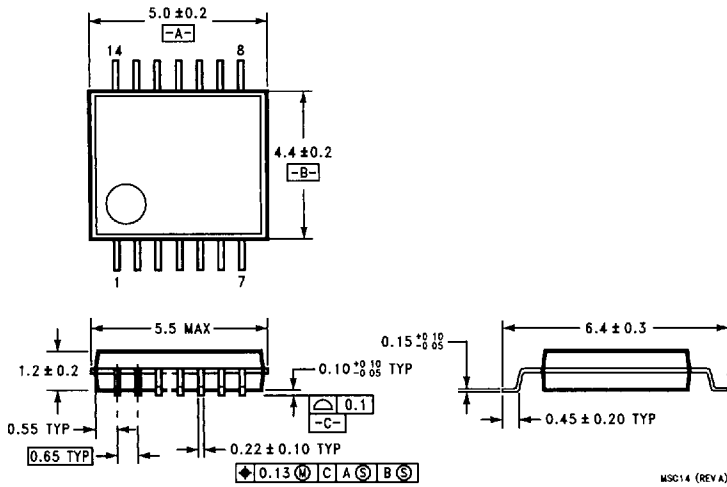

14-Lead Plastic EIAJ SSOP Type I (MSC)
Order Number 74VHC04MSCX or 74VHCT04MSCX
NS Package Number MSC14

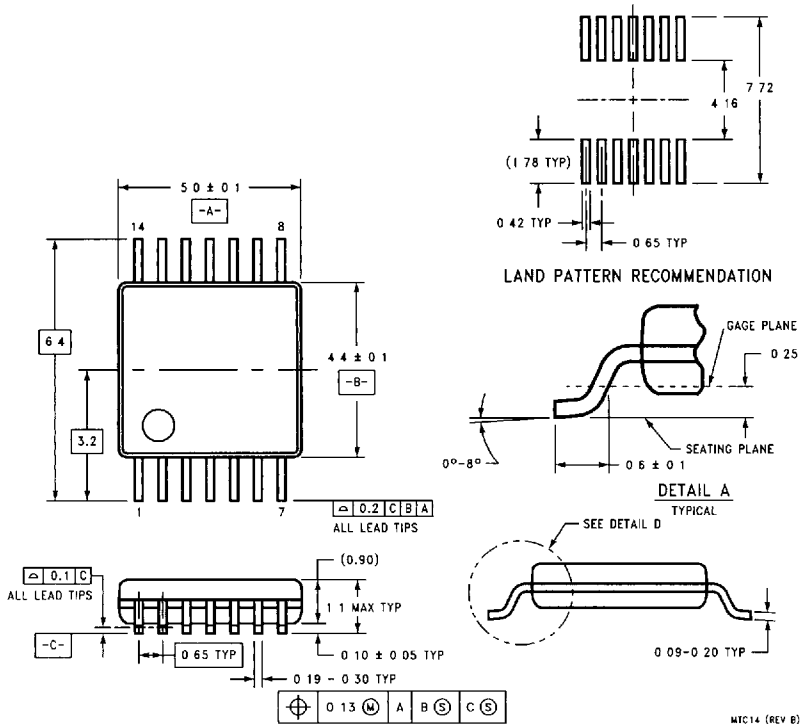

14-Lead Plastic EIAJ TSSOP Type I (MTC)
Order Number 74VHC04MTC, 74VHC04MTCX, 74VHCT04MTC or 74VHCT04MTCX
NS Package Number MTC14

Physical Dimensions inches (millimeters) (Continued)

Lit. # 118004-002

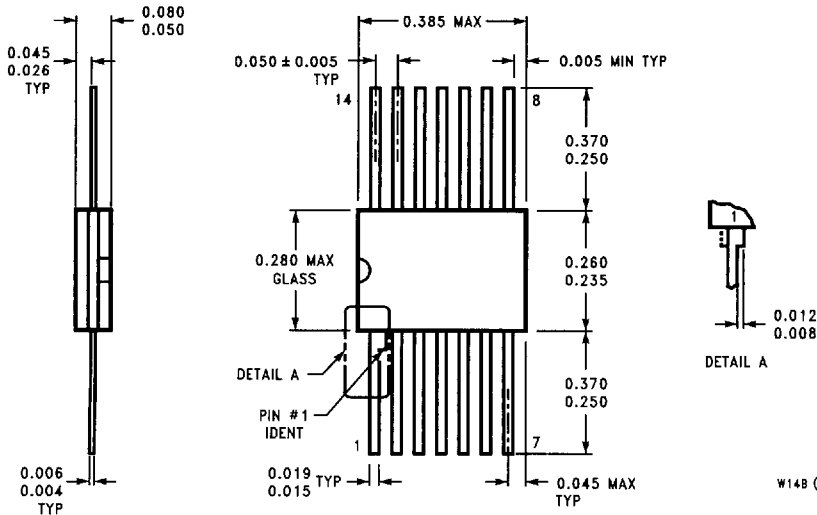

14-Lead Cerpack (F)
Order Number 54VHC04W/883 or 54VHCT04W/883
NS Package Number W14B

LIFE SUPPORT POLICY

NATIONAL'S PRODUCTS ARE NOT AUTHORIZED FOR USE AS CRITICAL COMPONENTS IN LIFE SUPPORT DEVICES OR SYSTEMS WITHOUT THE EXPRESS WRITTEN APPROVAL OF THE PRESIDENT OF NATIONAL SEMICONDUCTOR CORPORATION. As used herein:

1. Life support devices or systems are devices or systems which, (a) are intended for surgical implant into the body, or (b) support or sustain life, and whose failure to perform, when properly used in accordance with instructions for use provided in the labeling, can be reasonably expected to result in a significant injury to the user.
2. A critical component is any component of a life support device or system whose failure to perform can be reasonably expected to cause the failure of the life support device or system, or to affect its safety or effectiveness.



National Semiconductor Corporation
 2900 Semiconductor Drive
 P.O. Box 58090
 Santa Clara, CA 95052-8090
 Tel: 1(800) 272-9959
 TWX (910) 339-9240

National Semiconductor GmbH
 Industriestrasse 10
 D-82256 Fürstenfeldbruck
 Germany
 Tel: (0-81-41) 103-0
 Telex: 527649
 Fax: (0-81-41) 10-35-06

National Semiconductor Japan Ltd.
 Sumitomo Chemical Engineering Center
 Bldg 7F
 1-7-1, Nakase, Mihama-Ku
 Chiba-City,
 Chiba Prefecture 261
 Tel: (043) 299-2300
 Fax: (043) 299-2500

National Semiconductor Hong Kong Ltd.
 13th Floor Straight Block
 Ocean Centre 5 Canton Rd
 Tsimshatsui Kowloon
 Hong Kong
 Tel: (852) 737-1600
 Telex: 51292 NSHKL
 Fax: (852) 736-9960

National Semicondutores Do Brazil Ltda.
 Av. Bng. Fana Luna 1409
 6 Andar
 Cep-01451 Paulistano,
 Sao Paulo, SP, Brazil
 Tel: (55-11) 212-5066
 Telex: 391-1131931 NSBR BR
 Fax: (55-11) 212-1181

National Semiconductor (Australia) Pty. Ltd.
 16 Business Park Dr
 Notting Hill VIC 3168
 Australia
 Tel: (3) 558-9999
 Fax: (3) 558-9998

