

2KBP005 Thru 2KBP10

2 AMP SILICON BRIDGE RECTIFIER

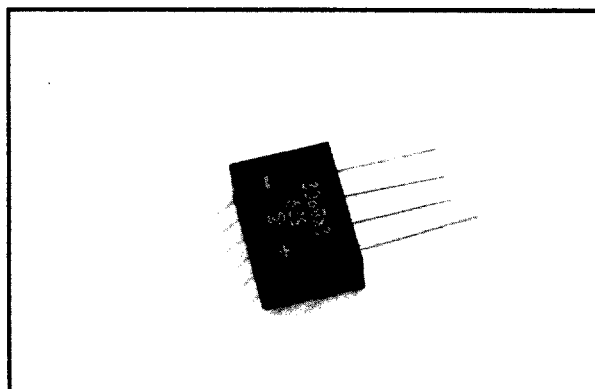

FEATURES

- Rating to 1000V PRV
- Surge overload rating to 50 Amperes peak
- Ideal for printed circuit board
- Reliable low cost construction utilizing molded plastic technique results in inexpensive product
- UL recognized: File #E106441
- UL recognized 94V-O plastic material

Mechanical Data

- Case: Molded plastic
- Leads: Silver plated copper
- Leads solderable per MIL-STD-202, Method 208
- Weight: 0.1 ounce, 2.76 grams

Outline Drawing

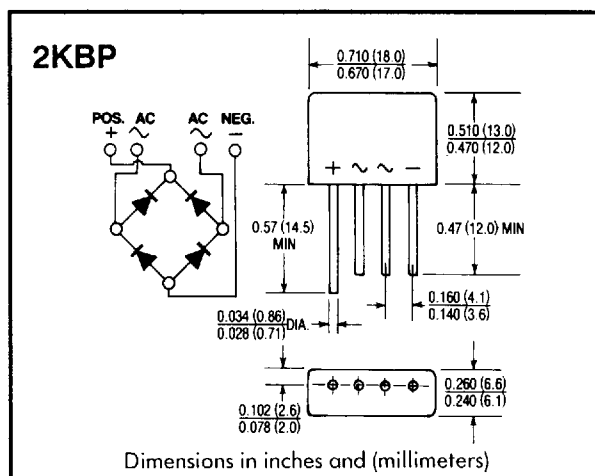

Maximum Ratings & Characteristics

- Ratings at 25° C ambient temperature unless otherwise specified
- Single phase, half wave, 60Hz, resistive or inductive load
- For capacitive load, derate current by 20%

		2KBP005	2KBP01	2KBP02	2KBP04	2KBP06	2KBP08	2KBP10	Units
Maximum Recurrent Peak Reverse Voltage	V_{RRM}	50	100	200	400	600	800	1000	V
Maximum RMS Voltage	V_{RMS}	35	70	140	280	420	560	700	V
Maximum DC Blocking Voltage	V_{DC}	60	100	200	400	600	800	1000	V
Maximum Average Forward Output Current @ $T_A = 25^\circ C$	I_{AV}	2.0							A
Peak Forward Surge Current 8.3 ms Single Half-Sine-Wave Superimposed On Rated Load	I_{FSM}	50							A
Maximum DC Forward Voltage Drop per Element At 1.0A DC	V_F	1.1							V
Maximum DC Reverse Current At Rated DC Blocking Voltage per Element @ $T_A = 100^\circ C$	I_R	10							μA
		1							mA
$I^2 t$ Rating for Fusing ($t < 8.3ms$)	$I^2 t$	10							$A^2 S$
Operating Temperature Range	T_J	-55 to +125							$^\circ C$
Storage Temperature Range	T_{STG}	-55 to +150							$^\circ C$