

IF AMPLIFIER IC
WITH ON-CHIP MIXER FOR DIGITAL CELLULAR PHONES

The μ PC8001 is a 3-volt IF amplifier IC with an on-chip mixer developed for digital cellular phones.

The μ PC8001 consists of a high-sensitivity limiter amplifier with an input frequency of 455 kHz, a high-speed and high-precision linear RSSI (received signal strength indicator), and a second mixer with an input frequency of 80 to 150 MHz.

The μ PC8001 features a low 3 mA (TYP.) and 2.2 μ A (TYP.) current consumption at normal operation and power-OFF, respectively. Its high-speed charge/discharge circuit enables fast power-ON/OFF switching.

The μ PC8001 boasts an extremely small size packaged in a 14-pin plastic shrink SOP, and low external capacitances of less than 0.01 μ F, in addition to an on-chip RSSI output resistor, and is most suitable for high-density mounting.

FEATURES

- Low-voltage operation...3 V \pm 10%
- Low power consumption...(V_{CC} = 3 V)

	Mixer	IF amp. + RSSI
During operation	2.1 mA (TYP.)	0.95 mA (TYP.)
At power-OFF	0 μ A (TYP.)	2.2 μ A (TYP.)

- High limiting sensitivity...-91 dBm (TYP.)
- High-precision RSSI linearity... \pm 0.5 dB (TYP.) (V_{IF IN} = -86 to -6 dBm)
- High-speed RSSI response time

RSSI output rise time	77 μ s (TYP.)
RSSI output fall time	113 μ s (TYP.)

- High-speed power-ON/OFF switching time

Rise time at power-ON	174 μ s (TYP.)
Fall time at power-OFF	3 μ s (TYP.)

- External capacitors of less than 0.01 μ F
- On-chip RSSI output resistor (34 k Ω)
- Ultra-compact package...14-pin plastic shrink SOP

The information in this document is subject to change without notice.

The mark \star shows revised points.

ORDERING INFORMATION

Part number	Package
μ PC8001GR	14-pin plastic shrink SOP (225 mil)
μ PC8001GR-E1	14-pin plastic shrink SOP (225 mil) Embossed carrier taping (Pin 1 located toward tape unwind direction)
μ PC8001GR-E2	14-pin plastic shrink SOP (225 mil) Embossed carrier taping (Pin 1 located toward tape wind direction)

BLOCK DIAGRAM

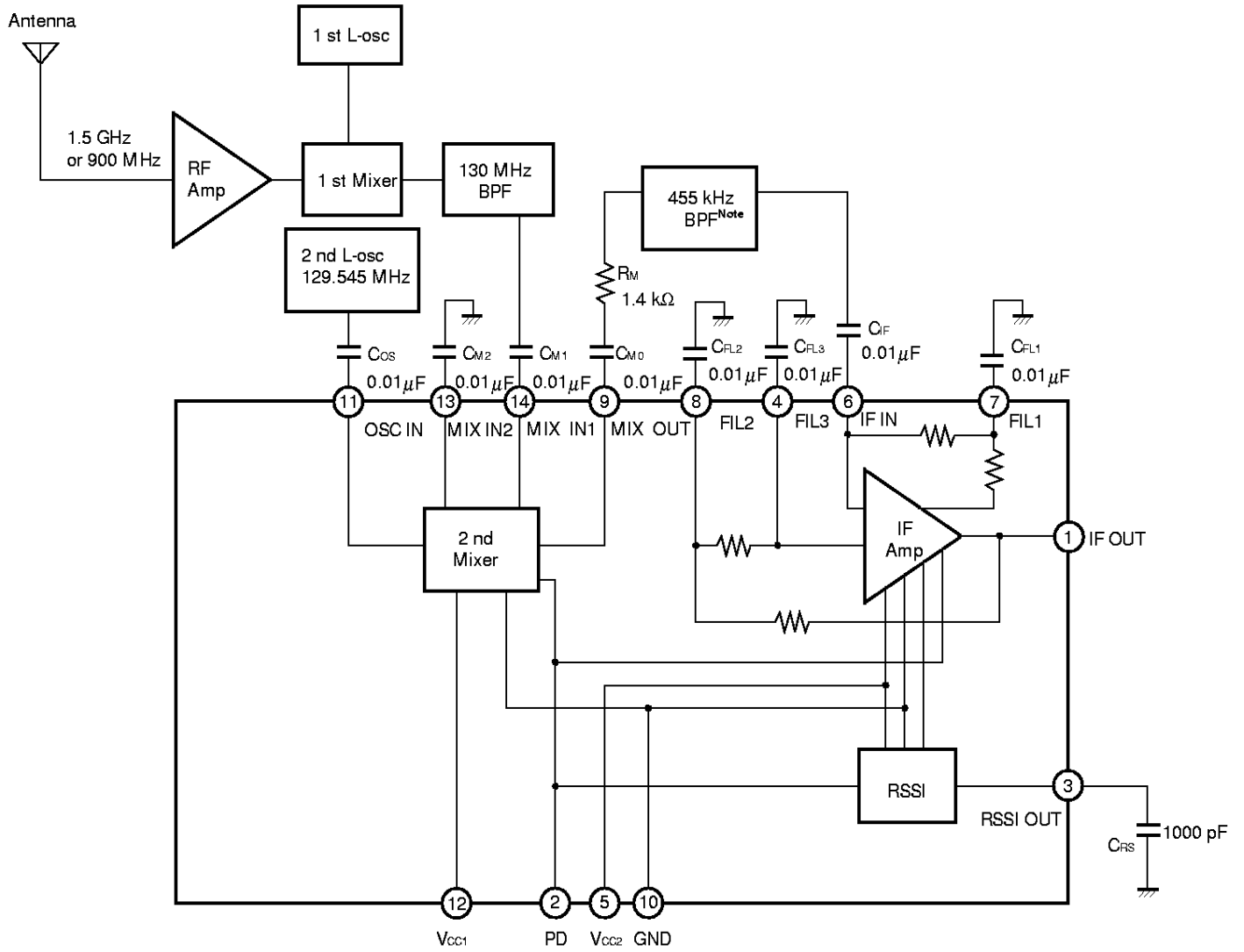

Note Input/output impedance of 455 kHz BPF: 1.5 k Ω

CONTENTS

1. PIN CONFIGURATION AND PIN FUNCTIONS	5
2. I/O EQUIVALENT CIRCUIT	7
3. ELECTRICAL SPECIFICATIONS	8
4. CHARACTERISTIC CURVES	14
5. TEST CIRCUIT EXAMPLE	18
6. PACKAGE DRAWINGS	19
7. RECOMMENDED SOLDERING CONDITIONS	20

1. PIN CONFIGURATION AND PIN FUNCTIONS

(1) PIN CONFIGURATION (Top View)

- 14-pin plastic shrink SOP (225 mil)

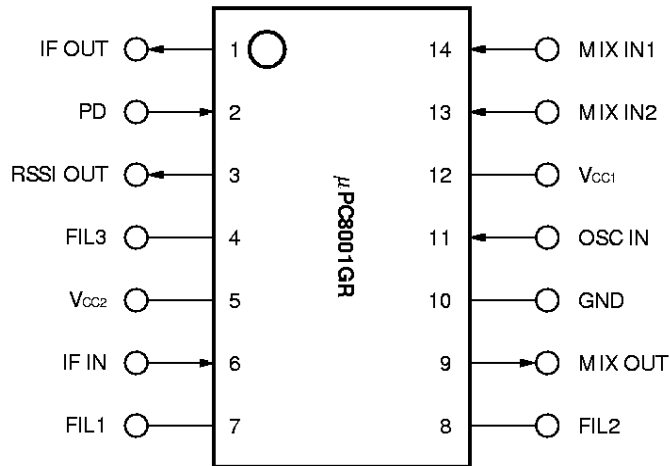

- FIL1-FIL3 : Filter
- GND : Ground
- IF IN : Intermediate Frequency Input
- IF OUT : Intermediate Frequency Output
- MIX IN1, MIX IN2 : Mixer Input
- MIX OUT : Mixer Output
- OSC IN : Oscillator Input
- PD : Power Down
- RSSI OUT : Received Signal Strength Indicator Output
- Vcc1, Vcc2 : Power Supply

(2) PIN FUNCTIONS

Number	Pin Name	I/O	Function
1	IF OUT	O	IF amplifier output
2	PD	I	Power-ON/OFF control signal input High level: Power-ON; Low level: Power-OFF
3	PSSI OUT	O	RSSI output
4	FIL3	—	Connect capacitor for filter.
5	V _{CC2}	—	IF amplifier and RSSI power pin
6	IF IN	I	IF amplifier input
7	FIL1	—	Connect capacitor for filter.
8	FIL2	—	Connect capacitor for filter.
9	MIX OUT	O	Mixer output
10	GND	—	Ground pin
11	OSC IN	I	Oscillator input
12	V _{CC1}	—	Mixer power pin
13	MIX IN2	I	Connect capacitor for filter.
14	MIX IN1	I	Mixer input

2. I/O EQUIVALENT CIRCUIT

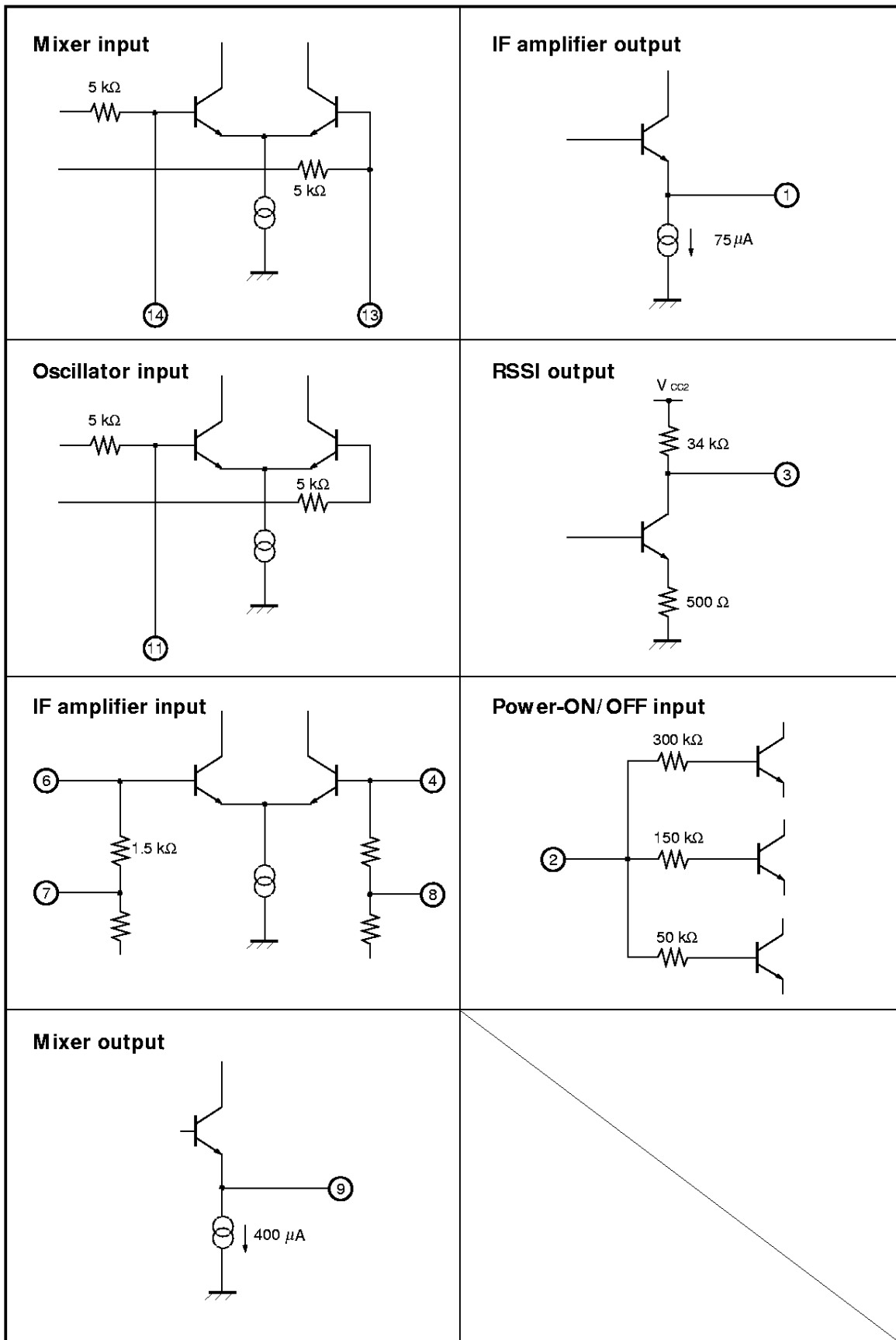

3. ELECTRICAL SPECIFICATIONS

Absolute Maximum Ratings (TA = 25°C)

Parameter	Symbol	Conditions	Rating	Unit
Supply voltage	V _{CC}		7	V
Total power dissipation	P _T		300	mW
Operating ambient temperature	T _A		-30 to +85	°C
Storage temperature	T _{stg}		-40 to +125	°C

Caution Exposure to Absolute Maximum Ratings for extended periods may affect device reliability; exceeding the ratings could cause permanent damage. The parameters apply independently. The device should be operated within the limits specified under DC and AC Characteristics.

Recommended Operating Conditions (TA = 25°C)

Parameter	Symbol	Conditions	MIN.	TYP.	MAX.	Unit
Supply voltage	V _{CC}		2.7	3.0	3.3	V
Mixer input level	V _{MIX IN}	See Figure 3-1. 50 Ω termination	-100		-20	dBm ^{Note1}
		LC matching	-113 ^{Note2}		-33 ^{Note2}	dBm ^{Note1}
IF amplifier input level	V _{IF IN}		-86		-6	dBm ^{Note1}
Oscillator input level	V _{OSC IN}		-30	-15	-5	dBm ^{Note1}
IF amplifier input frequency	f _{IF IN}		400	455	500	kHz
Mixer input frequency	f _{MIX IN}		80	130	150	MHz
Mixer output frequency	f _{MIX OUT}		400	455	500	kHz

- Notes** 1. Assuming a conversion value of 50 Ω, 0 dBm = 0.2236 V_{rms}.
- 2. Depends on board wiring pattern, use as reference value.

ELECTRICAL CHARACTERISTICS

($T_A = 25^\circ\text{C}$, $V_{CC1} = V_{CC2} = 3\text{ V}$, $f_{\text{MIX IN}} = 130\text{ MHz}$, $f_{\text{OSC IN}} = 129.545\text{ MHz}$, $f_{\text{IF IN}} = 455\text{ kHz}$, $C_{RS} = 1000\text{ pF}$, $C_{OS} = C_{M1} = C_{M2} = C_{M0} = C_{IF} = C_{FL1} = C_{FL2} = C_{FL3} = 0.01\text{ }\mu\text{F}$, $0\text{ dBm} = 0.2236\text{ V}_{\text{rms}}$)

(1) Mixer

Parameter	Symbol	Conditions	MIN.	TYP.	MAX.	Unit	
Supply current	I_{CC1}	No signal		2.1	3.0	mA	
Conversion gain	CG	$V_{\text{MIN IN}} = -50\text{ dBm}$ $V_{\text{OSC IN}} = -15\text{ dBm}$ See Figure 3-1.	50Ω termination	15	20	23	dB
			LC matching		33 ^{Note 1}		
Third order intercept	IC_3	See Figure 3-2.	-13	-8		dBm	
-1dB compression output level	V_{OMIX}	$V_{\text{OSC IN}} = -15\text{ dBm}$ See Figure 3-3.	-5	0		dBm	
Cut-off frequency	f_c	-3 dB point	200	470		MHz	
Noise figure	NF	See Figure 3-6.		10 ^{Note 1}		dB	
Local isolation	IS_L		20	26		dB	
Mixer input impedance	Z_{IM}			48-j383		Ω	
Local input impedance	Z_{IL}			80-j425		Ω	
Output resistance	R_{OM}		60	120	180	Ω	
Power-ON rise time ^{Note2}	t_{ONM}	$V_{\text{ON}} = 3\text{ V}$ Rise time of PD signal : 10 ns		33	600	μs	
Power-OFF fall time ^{Note3}	t_{OFM}	$V_{\text{OF}} = 0\text{ V}$ Fall time of PD signal : 10 ns		3	200	μs	
Power-OFF supply current	I_{LM}	$V_{\text{OF}} = 0\text{ V}$		0	10	μA	

Notes 1. Depends on board wiring pattern, use as reference value.

2. Time until DC voltage of mixer output reaches ±10% of power-ON value.

3. Time until supply current reaches 10% of power-ON value.

(2) Power-ON/OFF

Parameter	Symbol	Conditions	MIN.	TYP.	MAX.	Unit
Power-ON input voltage	V_{ON}	Power-ON over V_{ON} and under V_{CC}		1.2	2.4	V
Power-OFF input voltage	V_{OF}	Power-OFF over GND and under V_{OF}	0.6	1.2		V
Power-ON input current	I_{ON}	$V_{\text{ON}} = 3\text{ V}$		48	75	μA

(3) IF Amplifier/ RSSI

Parameter	Symbol	Conditions	MIN.	TYP.	MAX.	Unit
Supply current	I _{CC2}	No signal		0.95	1.3	mA
IF amplifier output amplitude	V _O	V _{IF IN} = -20 dBm	1.2	1.5	1.8	V _{p-p}
Limiting sensitivity	LS	-3dB point, see Figure 4-5.		-91	-86	dBm
IF amplifier input impedance	Z _{IN}		1.2	1.5	1.8	kΩ
IF amplifier phase variation	Δφ	V _{IF IN} = -86 to -6 dBm See Figure 4-6 ^{Note1} .		11		deg
★ RSSI linearity	L _{RS}	V _{IF IN} = -86 to -6 dBm Recursive calculation with V _{IF IN} = -60 to -6 dBm		±0.5	±2	dB
RSSI slope	SL _{RS}	Recursive calculation with V _{IF IN} = -60 to -6 dBm	22.3	24.4	30.1	mV/dB
★ RSSI intercept	IC _{RS}	Recursive calculation with V _{IF IN} = -60 to -6 dBm See Figure 3-4.	-135	-118	-104	dBm
RSSI output voltage1	V _{R1}	V _{IF IN} = -86 dBm	0.50	0.79	0.98	V
★ RSSI output voltage 2	V _{R2}	V _{IF IN} = -46 dBm	1.60	1.79	1.90	V
RSSI output voltage 3	V _{R3}	V _{IF IN} = -6 dBm	2.70	2.75	2.82	V
RSSI output temperature stability	S _T	V _{IF IN} = -86 to -6 dBm, T _A = -30 to +85 °C		1		dB
★ RSSI rise time	t _{rRS}	V _{IF IN} = -6 dBm See Figure 3-5.		77	300	μs
★ RSSI fall time	t _{fRS}	V _{IF IN} = -6 dBm See Figure 3-5.		113	300	μs
★ RSSI output ripple	V _{RRS}	V _{IF IN} = -6 dBm		3	12	mV _{p-p}
Power-OFF supply current	I _{LI}	V _{OF} = 0 V		2.2	10	μA
Power-ON rise time ^{Note2}	t _{ONI}	V _{ON} = 3 V, V _{IF IN} = -86 dBm PD signal rise time: 10 ns		174	600	μs
Power-OFF fall time ^{Note3}	t _{OFl}	V _{OF} = 0 V PD signal fall time: 10 ns		3	200	μs
IF amplifier output slew rate	SR _O	V _{IF IN} = -20 dBm				V/μs
		Rise ^{Note4}		3.4		
		Fall ^{Note5}		3.8		
RSSI output resistance	R _{OR}		27	34	41	kΩ

- ★ **Notes** 1. Use the network analyzer at RBW = 3 Hz.
- 2. Time until RSSI output reaches ±10% of power-ON value.
- 3. Time until supply current reaches 10% of power-ON value.
- 4. Rise: 10% to 90%
- 5. Fall: 90% to 10%

Figure 3-1. Mixer Input

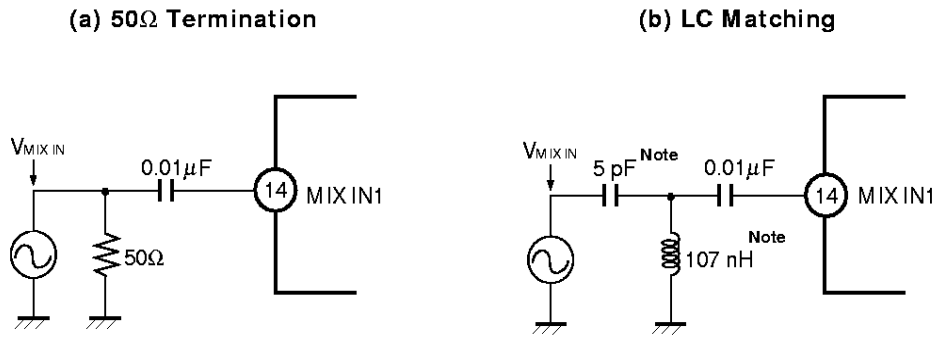

Note The values L and C are affected by the parasitic capacitance and inductance of the board. Therefore, adjust L and C so that the impedance at the MIX IN pin from the signal source equals 50Ω.

Remark The signal source impedance is 50Ω.

Figure 3-2. Third Order Intercept

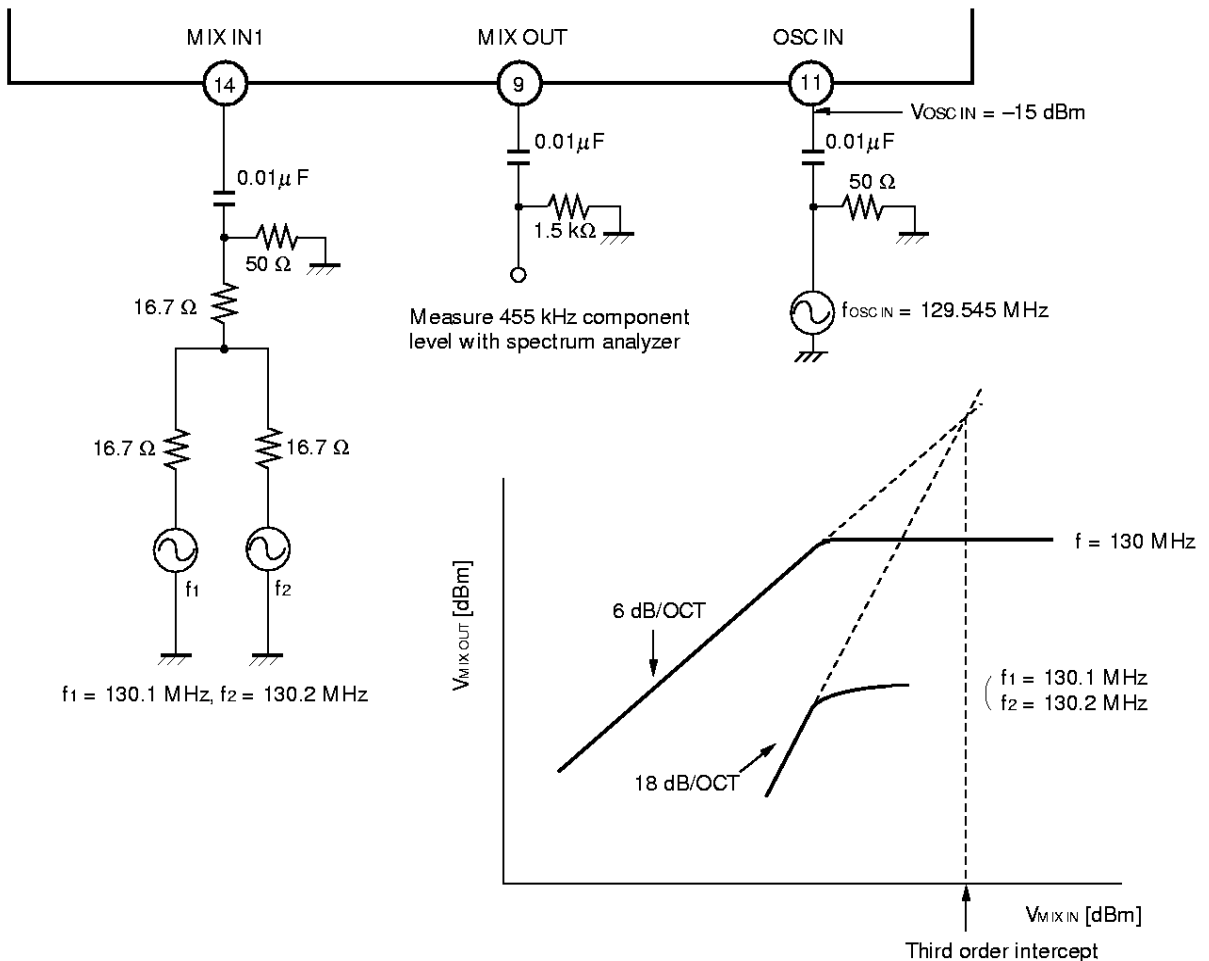

Remark Signal source impedance is 50Ω.

Figure 3-3. -1 dB Compression Output Level

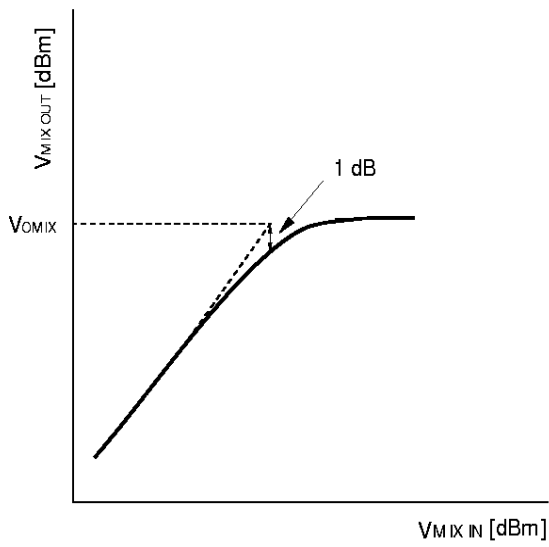

Figure 3-4. RSSI Intercept

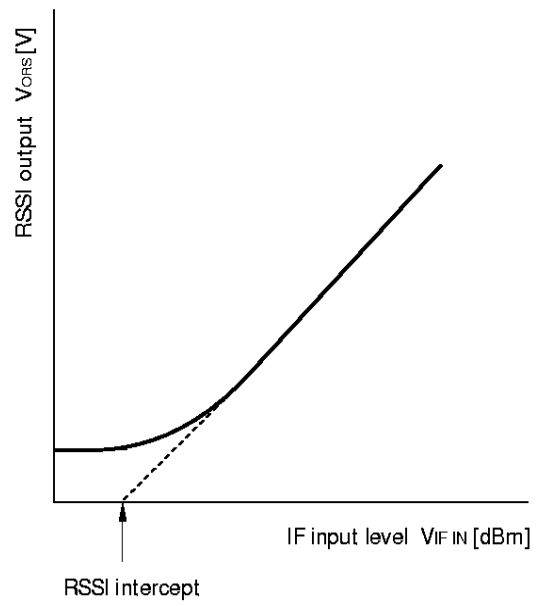

Figure 3-5. RSSI Response Time

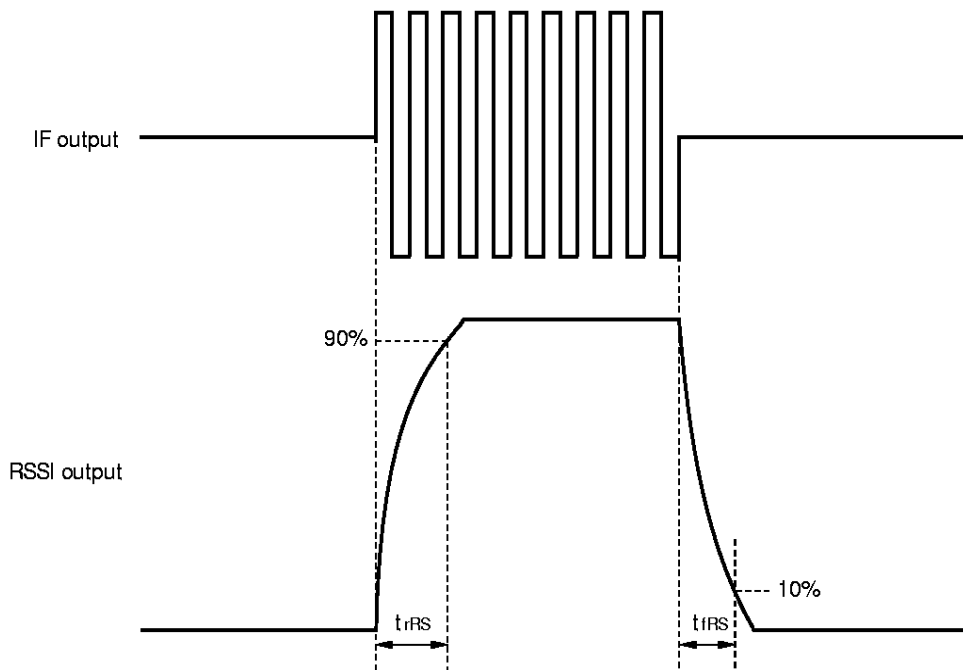
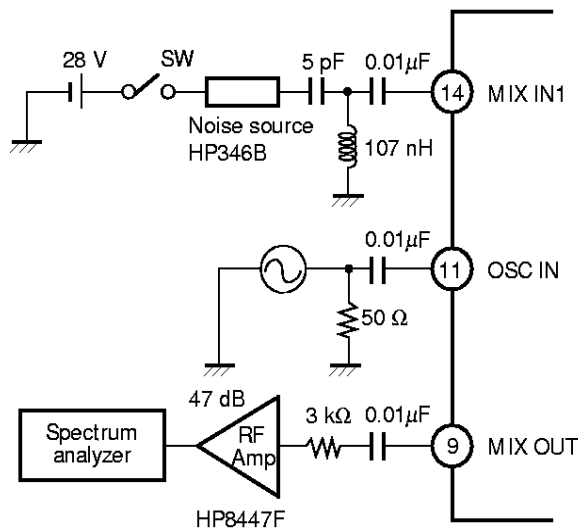

Figure 3-6. Noise Figure Measurement



The noise figure is calculated as follows:

$$NF = ENR - 10 \log (Y - 1)$$

NF (dB): Noise figure

ENR (dB): ENR of noise source

$$Y: Y = 10^{\frac{N_2 - N_1}{10}}$$

N₁ (dBm): Spectrum analyzer indication value at SW OFF.

N₂ (dBm): Spectrum analyzer indication value at SW ON.

Remark This measurement measures DSB. To measure SSB, add 3 dB to NF above.

4. CHARACTERISTIC CURVES

Figure 4-1. Mixer Supply Current vs. Supply Voltage

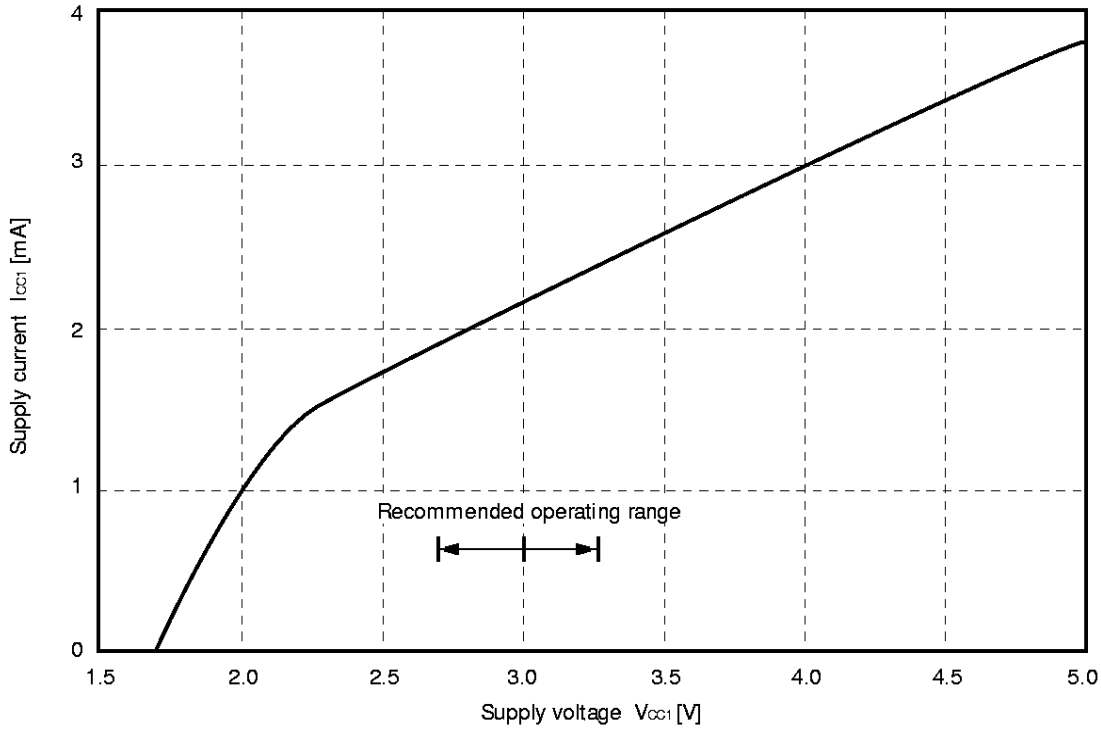

Figure 4-2. Mixer Output Level vs. Mixer Input Level
 ($f_{MIX IN} = 130$ MHz, $f_{OSC IN} = 129.545$ MHz, $f_{MIX OUT} = 455$ kHz, $V_{OSC IN} = -15$ dBm)

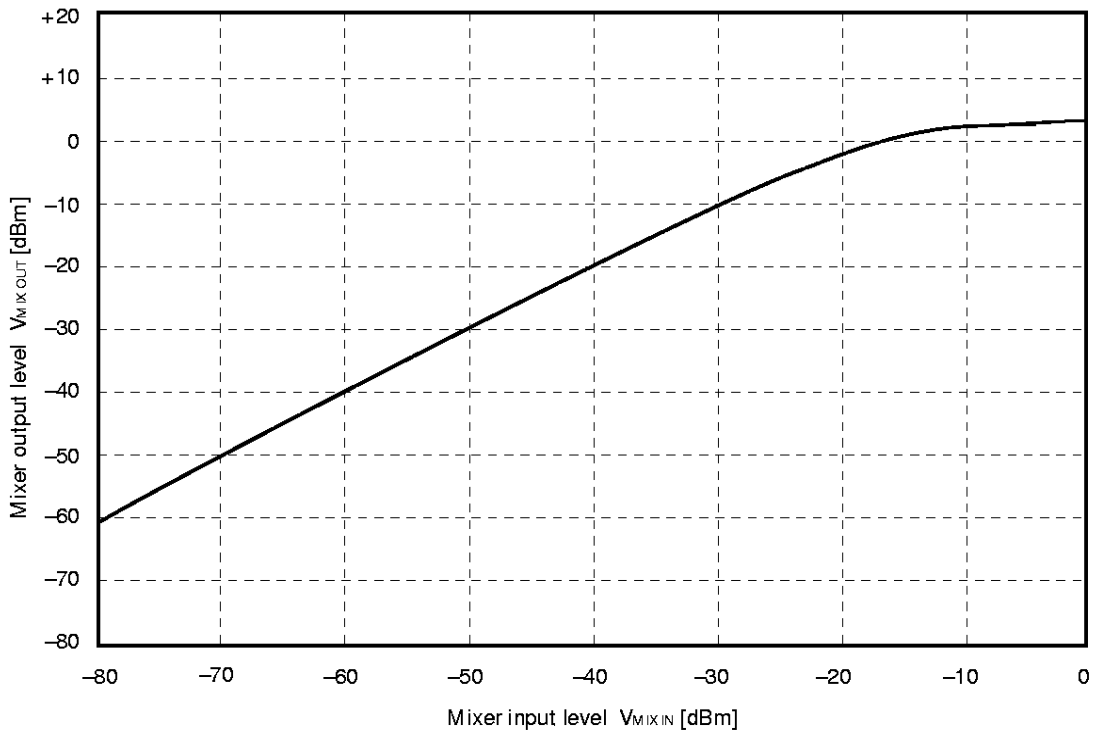

Figure 4-3. Mixer Conversion Gain vs. Mixer Input Frequency
 ($V_{MIX IN} = -30$ dBm, $V_{OSC IN} = -15$ dBm, $f_{OSC IN} = f_{MIX IN} - f_{MIX OUT}$, $f_{MIX OUT} = 455$ kHz)

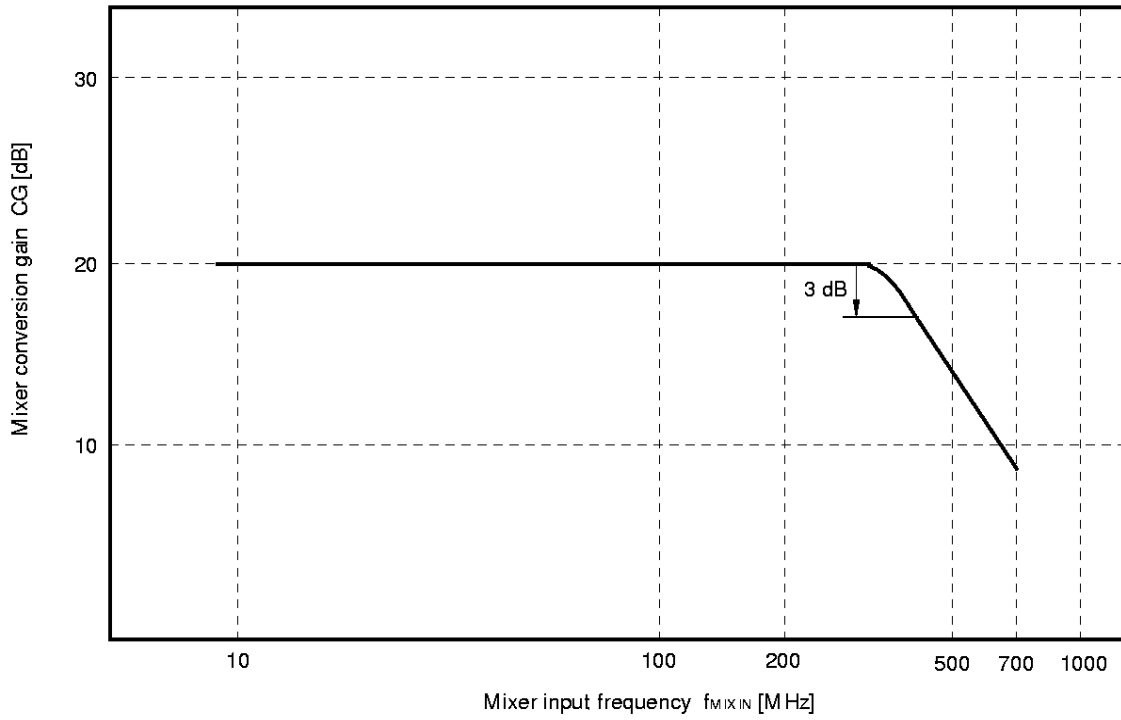

Figure 4-4. IF Amplifier/RSSI Supply Current vs. Supply Voltage

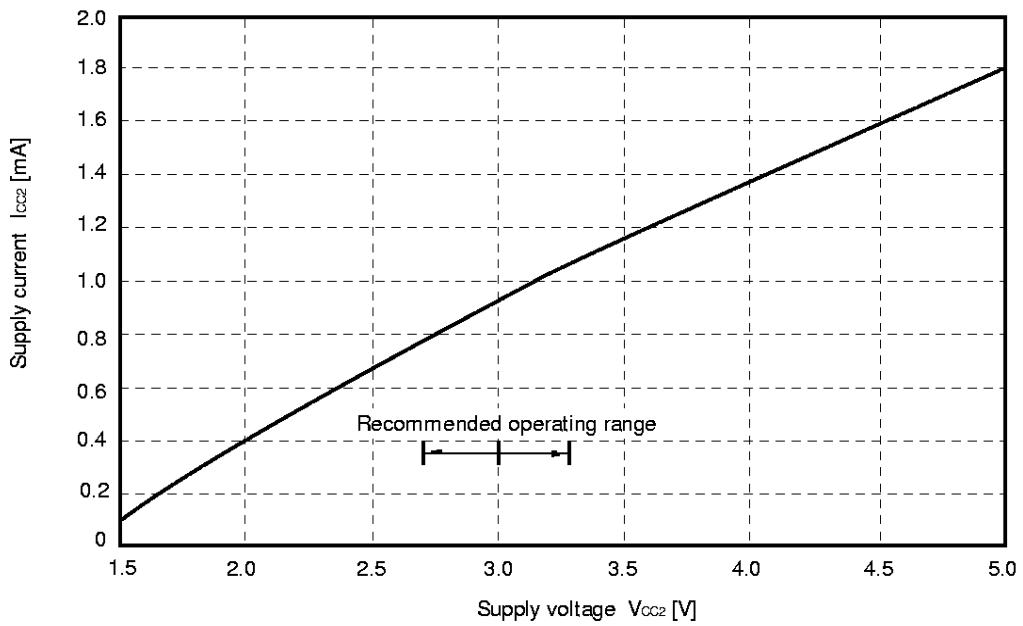

Figure 4-5. IF Amplifier Output Level vs. IF Amplifier Input Level

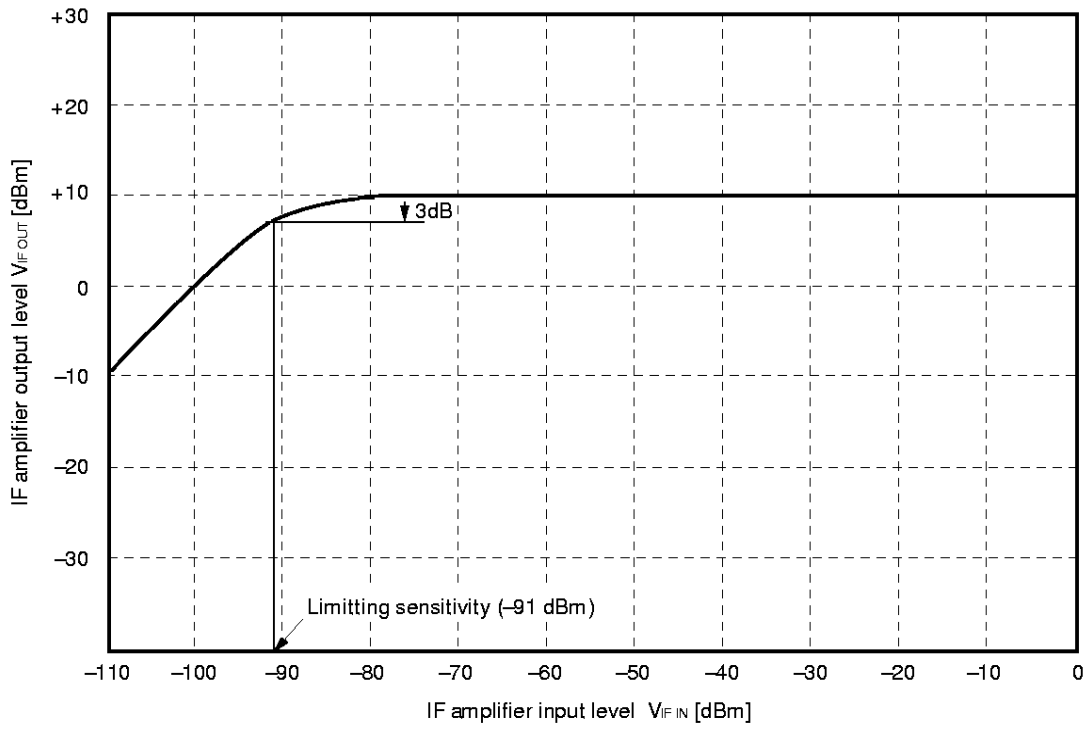

Figure 4-6. IF Amplifier Output Phase vs. IF Amplifier Input Level

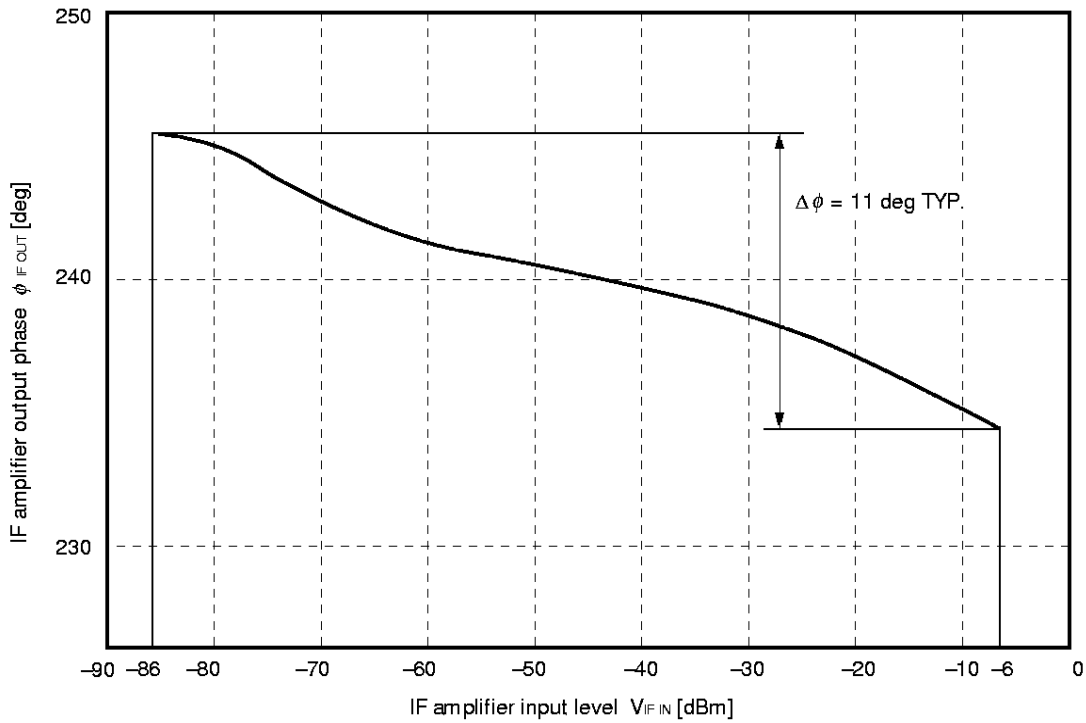
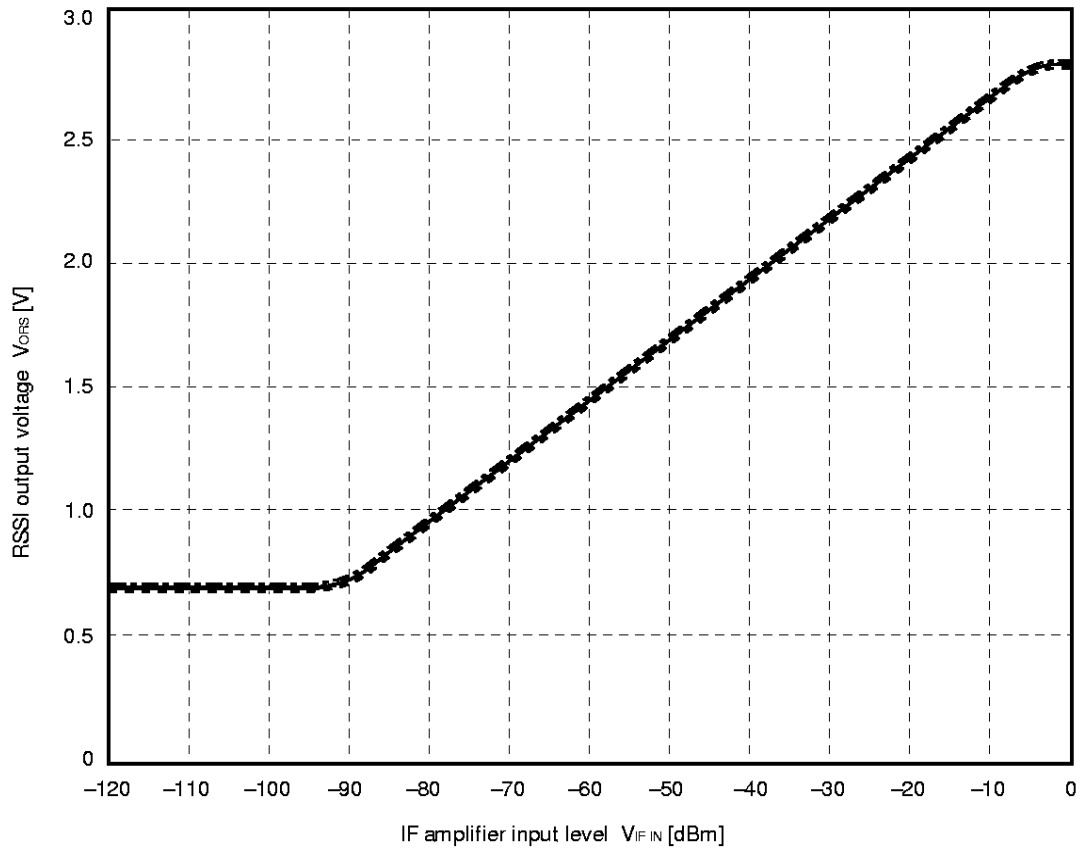

Figure 4-7. RSSI Output Voltage vs. IF Amplifier Input Level
(The temperature characteristics curves)

★



Remarks 1. ----- $T_A = -30\text{ °C}$
 ————— $T_A = +25\text{ °C}$
 - · - · - $T_A = +85\text{ °C}$

2. The three temperature characteristic curves are virtually identical.

★ 5. TEST CIRCUIT EXAMPLE

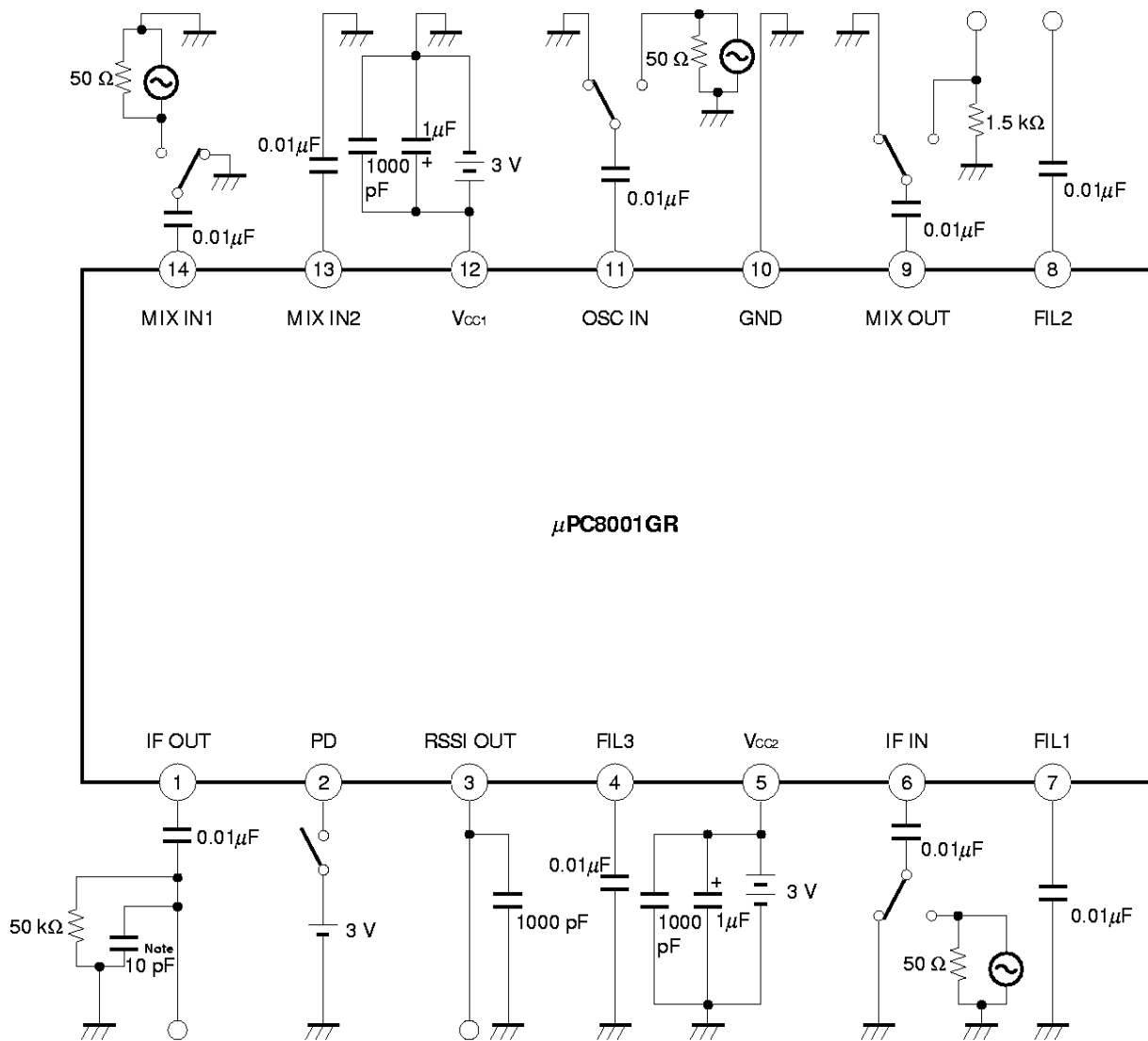

Note The value of the capacitance connected to the IF OUT pin (No. 1) includes the capacitances of PCB wiring patterns and the tester.

Remark In three cases of Mixer Input, Third Order Intercept and Noise Figure Measurement, refer to Figures 3-1, 3-2, and 3-6.

6. PACKAGE DRAWINGS

14 PIN PLASTIC SHRINK SOP (225 mil)

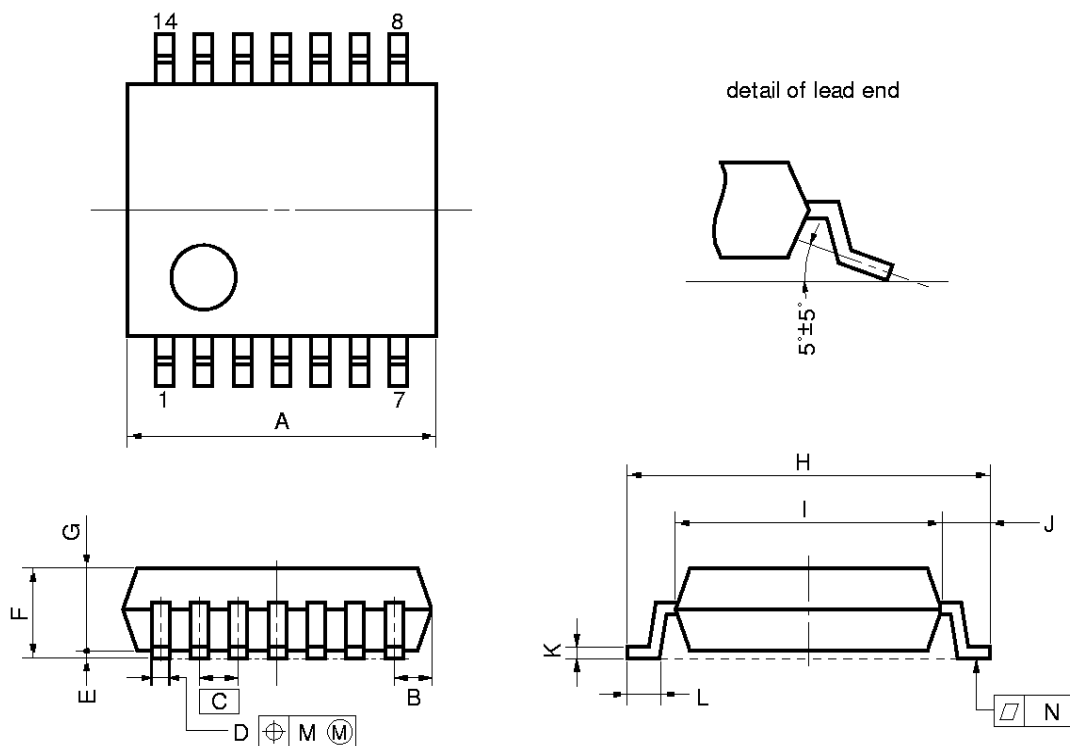

NOTE

Each lead centerline is located within 0.10 mm (0.004 inch) of its true position (T.P.) at maximum material condition.

P14GM-65-225B-2

ITEM	MILLIMETERS	INCHES
A	5.40 MAX.	0.213 MAX.
B	0.75 MAX.	0.030 MAX.
C	0.65 (T.P.)	0.026 (T.P.)
D	0.30 ^{+0.10} _{-0.05}	0.012 ^{+0.004} _{-0.003}
E	0.125±0.075	0.005±0.003
F	1.8 MAX.	0.071 MAX.
G	1.44	0.057
H	6.2±0.3	0.244±0.012
I	4.4	0.173
J	0.9	0.035
K	0.15 ^{+0.10} _{-0.05}	0.006 ^{+0.004} _{-0.002}
L	0.5±0.2	0.020 ^{+0.008} _{-0.009}
M	0.10	0.004
N	0.10	0.004

7. RECOMMENDED SOLDERING CONDITIONS

The following conditions must be met for soldering conditions of the μPC8001. For more details, refer to our document "SEMICONDUCTOR DEVICE MOUNTING TECHNOLOGY MANUAL" (IEI-1207).

Please consult with our sales offices in case other soldering process is used, or in case the soldering is done under different conditions.

Types of Surface Mount Device

μPC8001GR: 14-pin plastic shrink SOP (225 mil)

Soldedering process	Soldering conditions	Symbol
Infrared ray reflow	Peak temperature of package surface: 235 °C or below, Reflow time: 30 seconds or below (210 °C or higher), Number of reflow processes: MAX. 2 [Remark] (1) Please start the second reflow process after the temperature, raised by the first reflow process, returns to normal. (2) Please avoid removing the residual flux with water after the first reflow process.	IR35-107-2
Partial heating method	Terminal temperature: 300 °C or below, Time: 3 seconds or below (Per one side of the device).	—

Precautions Against Static Electricity

Caution When handling the device, be careful to protect it from static electricity. exposure to a strong static electricity charge may destroy internal transistor junctions. During transportation and storage, place the device in the conductive tray or case originally provided by NEC for shipping, or conductive shock absorbing material, metal case, etc. During assembly, be sure to ground the device. Be careful not to place the device on a plastic board and do not touch the device's pins.

[MEMO]

No part of this document may be copied or reproduced in any form or by any means without the prior written consent of NEC Corporation. NEC Corporation assumes no responsibility for any errors which may appear in this document.

NEC Corporation does not assume any liability for infringement of patents, copyrights or other intellectual property rights of third parties by or arising from use of a device described herein or any other liability arising from use of such device. No license, either express, implied or otherwise, is granted under any patents, copyrights or other intellectual property rights of NEC Corporation or others.

While NEC Corporation has been making continuous effort to enhance the reliability of its semiconductor devices, the possibility of defects cannot be eliminated entirely. To minimize risks of damage or injury to persons or property arising from a defect in an NEC semiconductor device, customer must incorporate sufficient safety measures in its design, such as redundancy, fire-containment, and anti-failure features.

NEC devices are classified into the following three quality grades:

"Standard", "Special", and "Specific". The Specific quality grade applies only to devices developed based on a customer designated "quality assurance program" for a specific application. The recommended applications of a device depend on its quality grade, as indicated below. Customers must check the quality grade of each device before using it in a particular application.

Standard: Computers, office equipment, communications equipment, test and measurement equipment, audio and visual equipment, home electronic appliances, machine tools, personal electronic equipment and industrial robots

Special: Transportation equipment (automobiles, trains, ships, etc.), traffic control systems, anti-disaster systems, anti-crime systems, safety equipment and medical equipment (not specifically designed for life support)

Specific: Aircrafts, aerospace equipment, submersible repeaters, nuclear reactor control systems, life support systems or medical equipment for life support, etc.

The quality grade of NEC devices in "Standard" unless otherwise specified in NEC's Data Sheets or Data Books. If customers intend to use NEC devices for applications other than those specified for Standard quality grade, they should contact NEC Sales Representative in advance.

Anti-radioactive design is not implemented in this product.