

DDR2 SDRAM Mini-RDIMM

MT18HTS25672PKY – 2GB

MT18HTS51272PKY – 4GB

Features

- 244-pin, mini registered dual in-line memory module
- Fast data transfer rates: PC2-5300, PC2-4200, or PC2-3200
- 2GB (256 Meg x 72) or 4GB (512 Meg x 72)
- Supports ECC error detection and correction
- Dual-rank, TwinDie™ (2COB) DRAM devices
- $V_{DD} = V_{DDQ} = 1.8V$
- $V_{DDSPD} = 1.7-3.6V$
- JEDEC-standard 1.8V I/O (SSTL_18-compatible)
- Differential data strobe (DQS, DQS#) option
- 4n-bit prefetch architecture
- Multiple internal device banks for concurrent operation
- Programmable CAS latency (CL)
- Posted CAS additive latency (AL)
- WRITE latency = READ latency - 1 t_{CK}
- Programmable burst length (BL) 4 or 8
- Adjustable data-output drive strength
- 64ms, 8192-cycle refresh
- On-die termination (ODT)
- Serial presence-detect (SPD) with EEPROM
- Phase-lock loop (PLL) to reduce loading on system clock
- Gold edge contacts
- Lead-free

Figure 1: 244-Pin Mini-RDIMM (MO-244 R/C X)

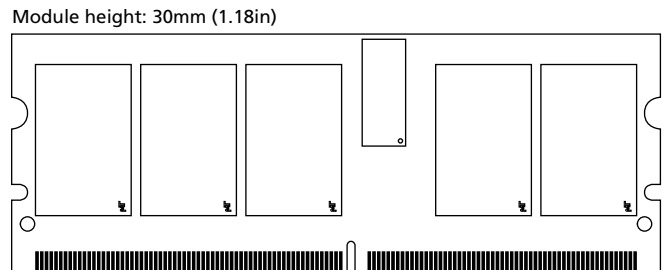

Options

- Parity
- Operating temperature
 - Commercial ($0^{\circ}C \leq T_A \leq 70^{\circ}C$)
 - Industrial ($-40^{\circ}C \leq T_A \leq 85^{\circ}C$)¹
- Package
 - 244-pin DIMM (lead-free)
- Frequency/CL²
 - 2.5ns @ CL = 5 (DDR2-800)
 - 3.0ns @ CL = 5 (DDR2-667)

Marking

P
None
I
Y
-80E
-667

- Notes:
1. Contact Micron for industrial temperature module offerings.
 2. CL = CAS (READ) latency; registered mode will add one clock cycle to CL.

Table 1: Key Timing Parameters

Speed Grade	Industry Nomenclature	Data Rate (MT/s)				t _{RCD} (ns)	t _{RP} (ns)	t _{RC} (ns)
		CL = 6	CL = 5	CL = 4	CL = 3			
-80E	PC2-6400	800	800	533	400	12.5	12.5	55
-800	PC2-6400	800	667	533	400	15	15	55
-667	PC2-5300	–	667	553	400	15	15	55
-53E	PC2-4200	–	–	553	400	15	15	55
-40E	PC2-3200	–	–	400	400	15	15	55



Table 2: Addressing

Parameter	2GB	4GB
Refresh count	8K	8K
Row address	16K A[13:0]	32K A[14:0]
Device bank address	8 BA[2:0]	8 BA[2:0]
TwinDie device configuration	2Gb TwinDie (256 Meg x 8)	4Gb TwinDie (512 Meg x 8)
Column address	1K A[9:0]	1K A[9:0]
Module rank address	2 S#[1:0]	2 S#[1:0]

Table 3: Part Numbers and Timing Parameters – 2GB

Base Device: MT47H256M8THN,¹ 2Gb TwinDie DDR2 SDRAM

Part Number ²	Module Density	Configuration	Module Bandwidth	Memory Clock/ Data Rate	Clock Cycles (CL- ^t RCD- ^t RP)
MT18HTS25672PK(I)Y-80E__	2GB	256 Meg x 72	6.4 GB/s	2.5ns/800MT/s	5-5-5
MT18HTS25672PK(I)Y-667__	2GB	256 Meg x 72	5.3 GB/s	3.0ns/667 MT/s	5-5-5

Table 4: Part Numbers and Timing Parameters – 4GB

Base Device: MT47H512M8THM,¹ 4Gb TwinDie DDR2 SDRAM

Part Number ²	Module Density	Configuration	Module Bandwidth	Memory Clock/ Data Rate	Clock Cycles (CL- ^t RCD- ^t RP)
MT18HTS51272PK(I)Y-80E__	4GB	512 Meg x 72	6.4 GB/s	2.5ns/800MT/s	5-5-5
MT18HTS51272PK(I)Y-667__	4GB	512 Meg x 72	5.3 GB/s	3.0ns/667 MT/s	5-5-5

- Notes: 1. Data sheets for the base devices can be found on Micron's Web site.
2. All part numbers end with a two-place code (not shown) that designates component and PCB revisions. Consult factory for current revision codes. Example: MT18HTS25672PKY-667E1.



Pin Assignments

Table 5: Pin Assignments

244-Pin Mini-RDIMM Front								244-Pin Mini-RDIMM Back							
Pin	Symbol	Pin	Symbol	Pin	Symbol	Pin	Symbol	Pin	Symbol	Pin	Symbol	Pin	Symbol		
1	V _{REF}	32	V _{SS}	63	V _{DDQ}	94	DQS5#	123	V _{SS}	154	DQ28	185	A3	216	NF/ RDQS5#
2	V _{SS}	33	DQ24	64	A2	95	DQS5	124	DQ4	155	DQ29	186	A1	217	V _{SS}
3	DQ0	34	DQ25	65	V _{DD}	96	V _{SS}	125	DQ5	156	V _{SS}	187	V _{DD}	218	DQ46
4	DQ1	35	V _{SS}	66	V _{SS}	97	DQ42	126	V _{SS}	157	DM3/ RDQS3	188	CK0	219	DQ47
5	V _{SS}	36	DQS3#	67	V _{SS}	98	DQ43	127	DM0/ RDQS0	158	NF/ RDQS3#	189	CK0#	220	V _{SS}
6	DQS0#	37	DQS3	68	Par_In	99	V _{SS}	128	NF/ RDQS0#	159	V _{SS}	190	V _{DD}	221	DQ52
7	DQS0	38	V _{SS}	69	V _{DD}	100	DQ48	129	V _{SS}	160	DQ30	191	A0	222	DQ53
8	V _{SS}	39	DQ26	70	A10	101	DQ49	130	DQ6	161	DQ31	192	BA1	223	V _{SS}
9	DQ2	40	DQ27	71	BA0	102	V _{SS}	131	DQ7	162	V _{SS}	193	V _{DD}	224	RFU
10	DQ3	41	V _{SS}	72	V _{DD}	103	SA2	132	V _{SS}	163	CB4	194	RAS#	225	RFU
11	V _{SS}	42	CB0	73	WE#	104	NC	133	DQ12	164	CB5	195	V _{DDQ}	226	V _{SS}
12	DQ8	43	CB1	74	V _{DDQ}	105	V _{SS}	134	DQ13	165	V _{SS}	196	S0#	227	DM6/ RDQS6
13	DQ9	44	V _{SS}	75	CAS#	106	DQS6#	135	V _{SS}	166	DM8/ RDQS8	197	V _{DDQ}	228	NF/ RDQS6#
14	V _{SS}	45	DQS8#	76	V _{DDQ}	107	DQS6	136	DM1/ RDQS1	167	NF/ RDQS8#	198	ODT0	229	V _{SS}
15	DQS1#	46	DQS8	77	S1#	108	V _{SS}	137	NF/ RDQS1#	168	V _{SS}	199	A13	230	DQ54
16	DQS1	47	V _{SS}	78	ODT1	109	DQ50	138	V _{SS}	169	CB6	200	V _{DD}	231	DQ55
17	V _{SS}	48	CB2	79	V _{DDQ}	110	DQ51	139	NC	170	CB7	201	NC	232	V _{SS}
18	NC	49	CB3	80	NC	111	V _{SS}	140	NC	171	V _{SS}	202	V _{SS}	233	DQ60
19	NC	50	V _{SS}	81	V _{SS}	112	DQ56	141	V _{SS}	172	NC	203	DQ36	234	DQ61
20	V _{SS}	51	NC	82	DQ32	113	DQ57	142	DQ14	173	V _{DDQ}	204	DQ37	235	V _{SS}
21	DQ10	52	V _{DDQ}	83	DQ33	114	V _{SS}	143	DQ15	174	CKE1	205	V _{SS}	236	DM7/ RDQS7
22	DQ11	53	CKE0	84	V _{SS}	115	DQS7#	144	V _{SS}	175	V _{DD}	206	DM4/ RDQS4	237	NF/ RDQS7#
23	V _{SS}	54	V _{DD}	85	DQS4#	116	DQS7	145	DQ20	176	A15	207	NF/ RDQS4#	238	V _{SS}
24	DQ16	55	BA2	86	DQS4	117	V _{SS}	146	DQ21	177	NF/A14 ¹	208	V _{SS}	239	DQ62
25	DQ17	56	Err_Out#	87	V _{SS}	118	DQ58	147	V _{SS}	178	V _{DDQ}	209	DQ38	240	DQ63
26	V _{SS}	57	V _{DDQ}	88	DQ34	119	DQ59	148	DM2/ RDQS2	179	A12	210	DQ39	241	V _{SS}
27	DQS2#	58	A11	89	DQ35	120	V _{SS}	149	NF/ RDQS2#	180	A9	211	V _{SS}	242	SDA
28	DQS2	59	A7	90	V _{SS}	121	SA0	150	V _{SS}	181	V _{DD}	212	DQ44	243	SCL



2GB, 4GB (x72, DR) 244-Pin DDR2 Mini-RDIMM Pin Assignments

Table 5: Pin Assignments (Continued)

244-Pin Mini-RDIMM Front								244-Pin Mini-RDIMM Back							
Pin	Symbol	Pin	Symbol	Pin	Symbol	Pin	Symbol	Pin	Symbol	Pin	Symbol	Pin	Symbol	Pin	Symbol
29	V _{SS}	60	V _{DD}	91	DQ40	122	SA1	151	DQ22	182	A8	213	DQ45	244	V _{DDSPD}
30	DQ18	61	A5	92	DQ41			152	DQ23	183	A6	214	V _{SS}		
31	DQ19	62	A4	93	V _{SS}			153	V _{SS}	184	V _{DDQ}	215	DM5/ RDQ55		

Note: 1. Pin 177 is NF for 2GB and A14 for 4GB.

Pin Descriptions

The pin description table below is a comprehensive list of all possible pins for all DDR2 modules. All pins listed may not be supported on this module. See Pin Assignments for information specific to this module.

Table 6: Pin Descriptions

Symbol	Type	Description
Ax	Input	Address inputs: Provide the row address for ACTIVE commands, and the column address and auto precharge bit (A10) for READ/WRITE commands, to select one location out of the memory array in the respective bank. A10 sampled during a PRECHARGE command determines whether the PRECHARGE applies to one bank (A10 LOW, bank selected by BAx) or all banks (A10 HIGH). The address inputs also provide the op-code during a LOAD MODE command. See the Pin Assignments Table for density-specific addressing information.
BAx	Input	Bank address inputs: Define the device bank to which an ACTIVE, READ, WRITE, or PRECHARGE command is being applied. BA define which mode register (MR0, MR1, MR2, and MR3) is loaded during the LOAD MODE command.
CKx, CK#x	Input	Clock: Differential clock inputs. All control, command, and address input signals are sampled on the crossing of the positive edge of CK and the negative edge of CK#.
CKEx	Input	Clock enable: Enables (registered HIGH) and disables (registered LOW) internal circuitry and clocks on the DDR2 SDRAM.
DMx,	Input	Data mask (x8 devices only): DM is an input mask signal for write data. Input data is masked when DM is sampled HIGH, along with that input data, during a write access. Although DM pins are input-only, DM loading is designed to match that of the DQ and DQS pins.
ODTx	Input	On-die termination: Enables (registered HIGH) and disables (registered LOW) termination resistance internal to the DDR2 SDRAM. When enabled in normal operation, ODT is only applied to the following pins: DQ, DQS, DQS#, DM, and CB. The ODT input will be ignored if disabled via the LOAD MODE command.
Par_In	Input	Parity input: Parity bit for Ax, RAS#, CAS#, and WE#.
RAS#, CAS#, WE#	Input	Command inputs: RAS#, CAS#, and WE# (along with S#) define the command being entered.
RESET#	Input	Reset: Asynchronously forces all registered outputs LOW when RESET# is LOW. This signal can be used during power-up to ensure that CKE is LOW and DQ are High-Z.
S#x	Input	Chip select: Enables (registered LOW) and disables (registered HIGH) the command decoder.
SAx	Input	Serial address inputs: Used to configure the SPD EEPROM address range on the I ² C bus.
SCL	Input	Serial clock for SPD EEPROM: Used to synchronize communication to and from the SPD EEPROM on the I ² C bus.
CBx	I/O	Check bits. Used for system error detection and correction.
DQx	I/O	Data input/output: Bidirectional data bus.
DQSx, DQS#x	I/O	Data strobe: Travels with the DQ and is used to capture DQ at the DRAM or the controller. Output with read data; input with write data for source synchronous operation. DQS# is only used when differential data strobe mode is enabled via the LOAD MODE command.

Table 6: Pin Descriptions (Continued)

Symbol	Type	Description
SDA	I/O	Serial data: Used to transfer addresses and data into and out of the SPD EEPROM on the I ² C bus.
RDQSx, RDQS#x	Output	Redundant data strobe (x8 devices only): RDQS is enabled/disabled via the LOAD MODE command to the extended mode register (EMR). When RDQS is enabled, RDQS is output with read data only and is ignored during write data. When RDQS is disabled, RDQS becomes data mask (see DMx). RDQS# is only used when RDQS is enabled and differential data strobe mode is enabled.
Err_Out#	Output (open drain)	Parity error output: Parity error found on the command and address bus.
V _{DD} /V _{DDQ}	Supply	Power supply: 1.8V ±0.1V. The component V _{DD} and V _{DDQ} are connected to the module V _{DD} .
V _{DDSPD}	Supply	SPD EEPROM power supply: 1.7–3.6V.
V _{REF}	Supply	Reference voltage: V _{DD} /2.
V _{SS}	Supply	Ground.
NC	–	No connect: These pins are not connected on the module.
NF	–	No function: These pins are connected within the module, but provide no functionality.
NU	–	Not used: These pins are not used in specific module configurations/operations.
RFU	–	Reserved for future use.

Functional Block Diagram

Figure 2: Functional Block Diagram

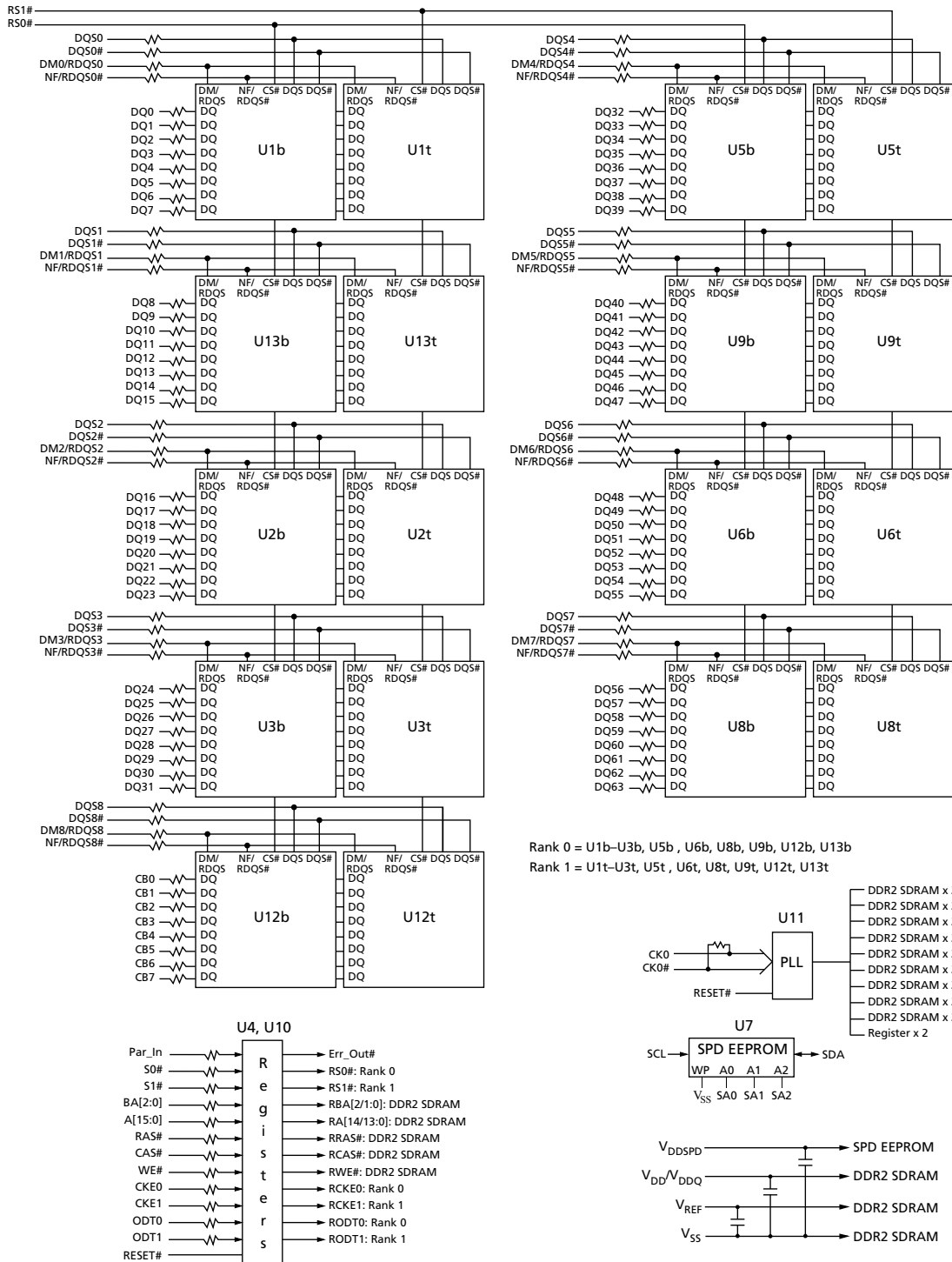

General Description

DDR2 SDRAM modules are high-speed, CMOS dynamic random access memory modules that use internally configured 4 or 8-bank DDR2 SDRAM devices. DDR2 SDRAM modules use DDR architecture to achieve high-speed operation. DDR2 architecture is essentially a $4n$ -prefetch architecture with an interface designed to transfer two data words per clock cycle at the I/O pins. A single read or write access for the DDR2 SDRAM module effectively consists of a single $4n$ -bit-wide, one-clock-cycle data transfer at the internal DRAM core and eight corresponding n -bit-wide, one-half-clock-cycle data transfers at the I/O pins.

DDR2 modules use two sets of differential signals: DQS, DQS# to capture data and CK and CK# to capture commands, addresses, and control signals. Differential clocks and data strobes ensure exceptional noise immunity for these signals and provide precise crossing points to capture input signals. A bidirectional data strobe (DQS, DQS#) is transmitted externally, along with data, for use in data capture at the receiver. DQS is a strobe transmitted by the DDR2 SDRAM device during READs and by the memory controller during WRITEs. DQS is edge-aligned with data for READs and center-aligned with data for WRITEs.

DDR2 SDRAM modules operate from a differential clock (CK and CK#); the crossing of CK going HIGH and CK# going LOW will be referred to as the positive edge of CK. Commands (address and control signals) are registered at every positive edge of CK. Input data is registered on both edges of DQS, and output data is referenced to both edges of DQS, as well as to both edges of CK.

Serial Presence-Detect EEPROM Operation

DDR2 SDRAM modules incorporate serial presence-detect. The SPD data is stored in a 256-byte EEPROM. The first 128 bytes are programmed by Micron to identify the module type and various SDRAM organizations and timing parameters. The remaining 128 bytes of storage are available for use by the customer. System READ/WRITE operations between the master (system logic) and the slave EEPROM device occur via a standard I²C bus using the DIMM's SCL (clock) SDA (data), and SA (address) pins. Write protect (WP) is connected to V_{SS}, permanently disabling hardware write protection.

Register and PLL Operation

DDR2 SDRAM modules operate in registered mode, where the command/address input signals are latched in the registers on the rising clock edge and sent to the DDR2 SDRAM devices on the following rising clock edge (data access is delayed by one clock cycle). A phase-lock loop (PLL) on the module receives and redrives the differential clock signals (CK, CK#) to the DDR2 SDRAM devices. The registers and PLL minimize system and clock loading. PLL clock timing is defined by JEDEC specifications and ensured by use of the JEDEC clock reference board. Registered mode will add one clock cycle to CL.

Parity Operations

The registering clock driver can accept a parity bit from the system's memory controller, providing even parity for the control, command, and address bus. Parity errors are flagged on the Err_Out# pin. Systems not using parity are expected to function without issue if Par_In and Err_Out# are left as no connects (NC) to the system.

Electrical Specifications

Stresses greater than those listed may cause permanent damage to the DRAM devices on the module. This is a stress rating only, and functional operation of the module at these or any other conditions outside those indicated on each device's data sheet is not implied. Exposure to absolute maximum rating conditions for extended periods may adversely affect reliability.

Table 7: Absolute Maximum DC Ratings

Symbol	Parameter	Min	Max	Units	
V_{DD}/V_{DDQ}	V_{DD}/V_{DDQ} supply voltage relative to V_{SS}	-0.5	2.3	V	
V_{IN}, V_{OUT}	Voltage on any pin relative to V_{SS}	-0.5	2.3	V	
I_I	Input leakage current; Any input $0V \leq V_{IN} \leq V_{DD}$; V_{REF} input $0V \leq V_{IN} \leq 0.95V$ (All other pins not under test = 0V)	Address inputs: RAS#, CAS#, WE# S#, CKE, BA, ODT	-5	5	μA
		CK, CK#	-250	250	
		DM	-10	10	
I_{OZ}	Output leakage current; $0V \leq V_{OUT} \leq V_{DDQ}$; DQs and ODT are disabled	-10	10	μA	
I_{VREF}	V_{REF} leakage current; V_{REF} = valid V_{REF} level	-36	36	μA	
T_A	Module ambient operating temperature	Commercial	0	70	$^{\circ}C$
		Industrial	-40	85	$^{\circ}C$
T_C^1	DDR2 SDRAM component case operating temperature ²	Commercial	0	85	$^{\circ}C$
		Industrial	-40	95	$^{\circ}C$

- Notes:
1. The refresh rate is required to double when $85^{\circ}C < T_C \leq 95^{\circ}C$.
 2. For further information, refer to technical note TN-00-08: "Thermal Applications," available on Micron's Web site.



DRAM Operating Conditions

Recommended AC operating conditions are given in the DDR2 component data sheets. Component specifications are available on Micron's Web site. Module speed grades correlate with component speed grades.

Table 8: Module and Component Speed Grades

DDR2 components may exceed the listed module speed grades; module may not be available in all listed speed grades

Module Speed Grade	Component Speed Grade
-1GA	-187E
-80E	-25E
-800	-25
-667	-3
-53E	-37E
-40E	-5E

Design Considerations

Simulations

Micron memory modules are designed to optimize signal integrity through carefully designed terminations, controlled board impedances, routing topologies, trace length matching, and decoupling. However, good signal integrity starts at the system level. Micron encourages designers to simulate the signal characteristics of the system's memory bus to ensure adequate signal integrity of the entire memory system.

Power

Operating voltages are specified at the DRAM, not at the edge connector of the module. Designers must account for any system voltage drops at anticipated power levels to ensure the required supply voltage is maintained.

I_{DD} Specifications

Table 9: I_{DD} Specifications and Conditions – 2GB

Values are shown for the MT47H256M8 DDR2 SDRAM only and are computed from values specified in the 2Gb TwinDie (256 Meg x 8) component data sheet

Parameter/Condition	Symbol	-80E	-667	Units	
Operating one bank active-precharge current: $t^{*}CK = t^{*}CK (I_{DD})$, $t^{*}RC = t^{*}RC (I_{DD})$, $t^{*}RAS = t^{*}RAS \text{ MIN} (I_{DD})$; CKE is HIGH, S# is HIGH between valid commands; Address bus inputs are switching; Data bus inputs are switching	I _{CDD0}	918	873	mA	
Operating one bank active-read-precharge current: I _{OUT} = 0mA; BL = 4, CL = CL (I _{DD}), AL = 0; $t^{*}CK = t^{*}CK (I_{DD})$, $t^{*}RC = t^{*}RC (I_{DD})$, $t^{*}RAS = t^{*}RAS \text{ MIN} (I_{DD})$, $t^{*}RCD = t^{*}RCD (I_{DD})$; CKE is HIGH, S# is HIGH between valid commands; Address bus inputs are switching; Data pattern is same as I _{DD4W}	I _{CDD1}	1098	1008	mA	
Precharge power-down current: All device banks idle; $t^{*}CK = t^{*}CK (I_{DD})$; CKE is LOW; Other control and address bus inputs are stable; Data bus inputs are floating	I _{CDD2P}	126	126	mA	
Precharge quiet standby current: All device banks idle; $t^{*}CK = t^{*}CK (I_{DD})$; CKE is HIGH, S# is HIGH; Other control and address bus inputs are stable; Data bus inputs are floating	I _{CDD2Q}	513	423	mA	
Precharge standby current: All device banks idle; $t^{*}CK = t^{*}CK (I_{DD})$; CKE is HIGH, S# is HIGH; Other control and address bus inputs are switching; Data bus inputs are switching	I _{CDD2N}	558	468	mA	
Active power-down current: All device banks open; $t^{*}CK = t^{*}CK (I_{DD})$; CKE is LOW; Other control and address bus inputs are stable; Data bus inputs are floating	Fast PDN exit MR[12] = 0	I _{CDD3P}	333	333	mA
		Slow PDN exit MR[12] = 1	153	153	mA
Active standby current: All device banks open; $t^{*}CK = t^{*}CK (I_{DD})$, $t^{*}RAS = t^{*}RAS \text{ MAX} (I_{DD})$, $t^{*}RP = t^{*}RP (I_{DD})$; CKE is HIGH, S# is HIGH between valid commands; Other control and address bus inputs are switching; Data bus inputs are switching	I _{CDD3N}	648	603	mA	
Operating burst write current: All device banks open; Continuous burst writes; BL = 4, CL = CL (I _{DD}), AL = 0; $t^{*}CK = t^{*}CK (I_{DD})$, $t^{*}RAS = t^{*}RAS \text{ MAX} (I_{DD})$, $t^{*}RP = t^{*}RP (I_{DD})$; CKE is HIGH, S# is HIGH between valid commands; Address bus inputs are switching; Data bus inputs are switching	I _{CDD4W}	1548	1323	mA	
Operating burst read current: All device banks open; Continuous burst reads; I _{OUT} = 0mA; BL = 4, CL = CL (I _{DD}), AL = 0; $t^{*}CK = t^{*}CK (I_{DD})$, $t^{*}RAS = t^{*}RAS \text{ MAX} (I_{DD})$, $t^{*}RP = t^{*}RP (I_{DD})$; CKE is HIGH, S# is HIGH between valid commands; Address bus inputs are switching; Data bus inputs are switching	I _{CDD4R}	1548	1323	mA	
Burst refresh current: $t^{*}CK = t^{*}CK (I_{DD})$; REFRESH command at every $t^{*}RFC (I_{DD})$ interval; CKE is HIGH, S# is HIGH between valid commands; Other control and address bus inputs are switching; Data bus inputs are switching	I _{CDD5}	2223	2043	mA	
Self refresh current: CK and CK# at 0V; CKE ≤ 0.2V; Other control and address bus inputs are floating; Data bus inputs are floating	I _{CDD6}	126	126	mA	
Operating bank interleave read current: All device banks interleaving reads; I _{OUT} = 0mA; BL = 4, CL = CL (I _{DD}), AL = $t^{*}RCD (I_{DD}) - 1 \times t^{*}CK (I_{DD})$; $t^{*}CK = t^{*}CK (I_{DD})$, $t^{*}RC = t^{*}RC (I_{DD})$, $t^{*}RRD = t^{*}RRD (I_{DD})$, $t^{*}RCD = t^{*}RCD (I_{DD})$; CKE is HIGH, S# is HIGH between valid commands; Address bus inputs are stable during deselects; Data bus inputs are switching	I _{CDD7}	3123	2628	mA	

Table 10: I_{DD} Specifications and Conditions – 4GB

Values are shown for the MT47H512M8 DDR2 SDRAM only and are computed from values specified in the 4Gb TwinDie (512 Meg x 8) component data sheet

Parameter/Condition	Symbol	-80E	-667	Units
Operating one bank active-precharge current: $t_{CK} = t_{CK} (I_{DD})$, $t_{RC} = t_{RC} (I_{DD})$, $t_{RAS} = t_{RAS} \text{ MIN} (I_{DD})$; CKE is HIGH, S# is HIGH between valid commands; Address bus inputs are switching; Data bus inputs are switching	I _{CDD0}	1017	1035	mA
Operating one bank active-read-precharge current: I _{OUT} = 0mA; BL = 4, CL = CL (I _{DD}), AL = 0; $t_{CK} = t_{CK} (I_{DD})$, $t_{RC} = t_{RC} (I_{DD})$, $t_{RAS} = t_{RAS} \text{ MIN} (I_{DD})$, $t_{RCD} = t_{RCD} (I_{DD})$; CKE is HIGH, S# is HIGH between valid commands; Address bus inputs are switching; Data pattern is same as I _{DD4W}	I _{CDD1}	1620	1440	mA
Precharge power-down current: All device banks idle; $t_{CK} = t_{CK} (I_{DD})$; CKE is LOW; Other control and address bus inputs are stable; Data bus inputs are floating	I _{CDD2P}	180	180	mA
Precharge quiet standby current: All device banks idle; $t_{CK} = t_{CK} (I_{DD})$; CKE is HIGH, S# is HIGH; Other control and address bus inputs are stable; Data bus inputs are floating	I _{CDD2Q}	675	585	mA
Precharge standby current: All device banks idle; $t_{CK} = t_{CK} (I_{DD})$; CKE is HIGH, S# is HIGH; Other control and address bus inputs are switching; Data bus inputs are switching	I _{CDD2N}	765	675	mA
Active power-down current: All device banks open; $t_{CK} = t_{CK} (I_{DD})$; CKE is LOW; Other control and address bus inputs are stable; Data bus inputs are floating	I _{CDD3P}	432	432	mA
		162	162	mA
Active standby current: All device banks open; $t_{CK} = t_{CK} (I_{DD})$, $t_{RAS} = t_{RAS} \text{ MAX} (I_{DD})$, $t_{RP} = t_{RP} (I_{DD})$; CKE is HIGH, S# is HIGH between valid commands; Other control and address bus inputs are switching; Data bus inputs are switching	I _{CDD3N}	720	630	mA
Operating burst write current: All device banks open; Continuous burst writes; BL = 4, CL = CL (I _{DD}), AL = 0; $t_{CK} = t_{CK} (I_{DD})$, $t_{RAS} = t_{RAS} \text{ MAX} (I_{DD})$, $t_{RP} = t_{RP} (I_{DD})$; CKE is HIGH, S# is HIGH between valid commands; Address bus inputs are switching; Data bus inputs are switching	I _{CDD4W}	1755	1485	mA
Operating burst read current: All device banks open; Continuous burst reads; I _{OUT} = 0mA; BL = 4, CL = CL (I _{DD}), AL = 0; $t_{CK} = t_{CK} (I_{DD})$, $t_{RAS} = t_{RAS} \text{ MAX} (I_{DD})$, $t_{RP} = t_{RP} (I_{DD})$; CKE is HIGH, S# is HIGH between valid commands; Address bus inputs are switching; Data bus inputs are switching	I _{CDD4R}	1845	1665	mA
Burst refresh current: $t_{CK} = t_{CK} (I_{DD})$; REFRESH command at every $t_{RFC} (I_{DD})$ interval; CKE is HIGH, S# is HIGH between valid commands; Other control and address bus inputs are switching; Data bus inputs are switching	I _{CDD5}	2835	2655	mA
Self refresh current: CK and CK# at 0V; CKE ≤ 0.2V; Other control and address bus inputs are floating; Data bus inputs are floating	I _{CDD6}	180	180	mA
Operating bank interleave read current: All device banks interleaving reads; I _{OUT} = 0mA; BL = 4, CL = CL (I _{DD}), AL = $t_{RCD} (I_{DD}) - 1 \times t_{CK} (I_{DD})$; $t_{CK} = t_{CK} (I_{DD})$, $t_{RC} = t_{RC} (I_{DD})$, $t_{RRD} = t_{RRD} (I_{DD})$, $t_{RCD} = t_{RCD} (I_{DD})$; CKE is HIGH, S# is HIGH between valid commands; Address bus inputs are stable during deselects; Data bus inputs are switching	I _{CDD7}	3645	3295	mA

Register and PLL Specifications

Table 11: Register Specifications

SSTU32866 devices or equivalent

Parameter	Symbol	Pins	Condition	Min	Max	Units
DC high-level input voltage	$V_{IH(DC)}$	Control, command, address	SSTL_18	$V_{REF(DC)} + 125$	$V_{DDQ} + 250$	mV
DC low-level input voltage	$V_{IL(DC)}$	Control, command, address	SSTL_18	0	$V_{REF(DC)} - 125$	mV
AC high-level input voltage	$V_{IH(AC)}$	Control, command, address	SSTL_18	$V_{REF(DC)} + 250$	–	mV
AC low-level input voltage	$V_{IL(AC)}$	Control, command, address	SSTL_18	–	$V_{REF(DC)} - 250$	mV
Output high voltage	V_{OH}	Parity output	LVC MOS	1.2	–	V
Output low voltage	V_{OL}	Parity output	LVC MOS	–	0.5	V
Input current	I_I	All pins	$V_I = V_{DD}$ or V_{SS}	–	0.5	μA
Static standby	I_{DD}	All pins	RESET# = V_{SSQ} ($I_o = 0$)	–5	5	mA
Static operating	I_{DD}	All pins	RESET# = V_{SS} ; $V_I = V_{IH(AC)}$ or $V_{IL(DC)}$, $I_o = 0$	–	100	mA
Dynamic operating (clock tree)	I_{DDD}	N/A	RESET# = V_{DD} ; $V_I = V_{IH(DC)}$ or $V_{IL(AC)}$, $I_o = 0$; CK and CK# switching 50% duty cycle	–	Varies by manufacturer	μA
Dynamic operating (per each input)	I_{DDD}	N/A	RESET# = V_{DD} ; $V_I = V_{IH(AC)}$ or $V_{IL(DC)}$, $I_o = 0$; CK and CK# switching 50% duty cycle; One data in/out switching at $t_{CK}/2$, 50% duty cycle	–	Varies by manufacturer	μA
Input capacitance (per device, per pin)	C_{IN}	All inputs except RESET#	$V_I = V_{REF} \pm 250mV$; $V_{DD} = 1.8V$	2.5	3.5	pF
Input capacitance (per device, per pin)	C_{IN}	RESET#	$V_I = V_{DD}$ or V_{SS}	Varies by manufacturer	Varies by manufacturer	pF

Note: 1. Timing and switching specifications for the register listed are critical for proper operation of the DDR2 SDRAM RDIMMs. These are meant to be a subset of the parameters for the specific device used on the module. Detailed information for this register is available in JEDEC standard JESD82.

Table 12: PLL Specifications

CU877 device or equivalent

Parameter	Symbol	Pins	Condition	Min	Max	Units
DC high-level input voltage	V_{IH}	RESET#	LVC MOS	$0.65 \times V_{DD}$	–	V
DC low-level input voltage	V_{IL}	RESET#	LVC MOS	–	$0.35 \times V_{DD}$	V
Input voltage (limits)	V_{IN}	RESET#, CK, CK#	–	0.3	$V_{DD} + 0.3$	V
DC high-level input voltage	V_{IH}	CK, CK#	Differential input	$0.65 \times V_{DD}$	–	V
DC low-level input voltage	V_{IL}	CK, CK#	Differential input	–	$0.35 \times V_{DD}$	V
Input differential-pair cross voltage	V_{IX}	CK, CK#	Differential input	$(V_{DDQ}/2) - 0.15$	$(V_{DD}/2) - 0.15$	V
Input differential voltage	$V_{ID(DC)}$	CK, CK#	Differential input	0.3	$V_{DD} - 0.4$	V
Input differential voltage	$V_{ID(AC)}$	CK, CK#	Differential input	0.6	$V_{DD} - 0.4$	V
Input current	I_I	RESET#	$V_I = V_{DD}$ or V_{SS}	–10	10	μA
		CK, CK#	$V_I = V_{DD}$ or V_{SS}	–250	250	μA
Output disabled current	I_{ODL}		RESET# = V_{SS} ; $V_I = V_{IH(AC)}$ or $V_{IL(DC)}$	100	–	μA
Static supply current	$I_{DDL D}$		CK = CK# = LOW	–	500	μA
Dynamic supply	I_{DD}	N/A	CK, CK# = 270 MHz, all outputs open (not connected to PCB)	–	300	mA
Input capacitance	C_{IN}	Each input	$V_I = V_{DD}$ or V_{SS}	2	3	pF

Table 13: PLL Clock Driver Timing Requirements and Switching Characteristics

Parameter	Symbol	Min	Max	Units
Stabilization time	t_L	–	15	μs
Input clock slew rate	slr(i)	1.0	4.0	V/ns
SSC modulation frequency	–	30	33	kHz
SSC clock input frequency deviation	–	0.0	–0.5	%
PLL loop bandwidth (–3dB from unity gain)	–	2.0	–	MHz

Note: 1. PLL timing and switching specifications are critical for proper operation of the DDR2 DIMM. This is a subset of parameters for the specific PLL used. Detailed PLL information is available in JEDEC standard JESD82.

Serial Presence-Detect

For the latest SPD data, refer to Micron's SPD page: www.micron.com/SPD.

Table 14: SPD EEPROM Operating Conditions

Parameter/Condition	Symbol	Min	Max	Units
Supply voltage	V_{DDSPD}	1.7	3.6	V
Input high voltage: logic 1; All inputs	V_{IH}	$V_{DDSPD} \times 0.7$	$V_{DDSPD} + 0.5$	V
Input low voltage: logic 0; All inputs	V_{IL}	-0.6	$V_{DDSPD} \times 0.3$	V
Output low voltage: $I_{OUT} = 3\text{mA}$	V_{OL}	-	0.4	V
Input leakage current: $V_{IN} = \text{GND to } V_{DD}$	I_{LI}	0.1	3	μA
Output leakage current: $V_{OUT} = \text{GND to } V_{DD}$	I_{LO}	0.05	3	μA
Standby current	I_{SB}	1.6	4	μA
Power supply current, READ: SCL clock frequency = 100 kHz	I_{CCR}	0.4	1	mA
Power supply current, WRITE: SCL clock frequency = 100 kHz	I_{CCW}	2	3	mA

Table 15: SPD EEPROM AC Operating Conditions

Parameter/Condition	Symbol	Min	Max	Units	Notes
SCL LOW to SDA data-out valid	t_{AA}	0.2	0.9	μs	1
Time bus must be free before a new transition can start	t_{BUF}	1.3	-	μs	
Data-out hold time	t_{DH}	200	-	ns	
SDA and SCL fall time	t_F	-	300	ns	2
SDA and SCL rise time	t_R	-	300	ns	2
Data-in hold time	$t_{HD:DAT}$	0	-	μs	
Start condition hold time	$t_{HD:STA}$	0.6	-	μs	
Clock HIGH period	t_{HIGH}	0.6	-	μs	
Noise suppression time constant at SCL, SDA inputs	t_I	-	50	μs	
Clock LOW period	t_{LOW}	1.3	-	μs	
SCL clock frequency	t_{SCL}	-	400	kHz	
Data-in setup time	$t_{SU:DAT}$	100	-	ns	
Start condition setup time	$t_{SU:STA}$	0.6	-	μs	3
Stop condition setup time	$t_{SU:STO}$	0.6	-	μs	
WRITE cycle time	t_{WRC}	-	10	ms	4

- Notes:
1. To avoid spurious start and stop conditions, a minimum delay is placed between SCL = 1 and the falling or rising edge of SDA.
 2. This parameter is sampled.
 3. For a restart condition or following a WRITE cycle.
 4. The SPD EEPROM WRITE cycle time (t_{WRC}) is the time from a valid stop condition of a write sequence to the end of the EEPROM internal ERASE/PROGRAM cycle. During the WRITE cycle, the EEPROM bus interface circuit is disabled, SDA remains HIGH due to pull-up resistance, and the EEPROM does not respond to its slave address.

Module Dimensions

Figure 3: 244-Pin DDR2 Mini-RDIMM

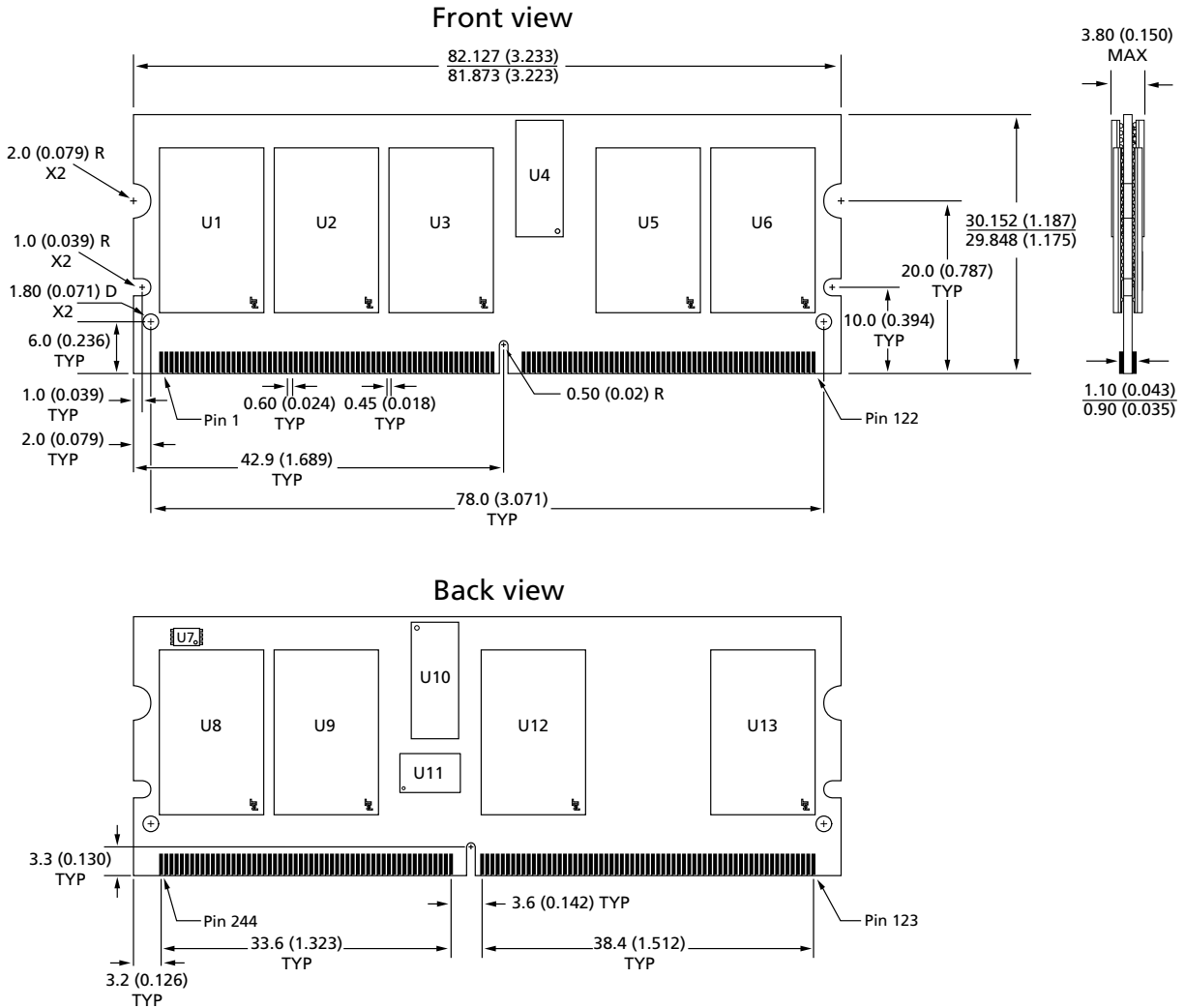

- Notes: 1. All dimensions are in millimeters (inches); MAX/MIN or typical (TYP) where noted.
 2. The dimensional diagram is for reference only. Refer to the JEDEC MO document for additional design dimensions.

8000 S. Federal Way, P.O. Box 6, Boise, ID 83707-0006, Tel: 208-368-3900
www.micron.com/productsupport Customer Comment Line: 800-932-4992
 Micron and the Micron logo are trademarks of Micron Technology, Inc.
 All other trademarks are the property of their respective owners.

This data sheet contains minimum and maximum limits specified over the power supply and temperature range set forth herein. Although considered final, these specifications are subject to change, as further product development and data characterization sometimes occur.