

## CMOS DUAL 2-WIDE, 2-INPUT AND-OR-INVERTER GATE

### FEATURES

- Medium-speed operation —  $t_{PHL} = 90$  ns;  
 $t_{PLH} = 125$  ns (typ.) at 10 V
- Individual inhibit controls
- Standardized symmetrical output characteristics
- 100% tested for quiescent current at 18 V
- Maximum input current of  $1 \mu\text{A}$  at 15 V over full temperature range; 100 nA at 15 V and 25° C
- Noise margin (over full package-temperature range):
  - 1 V at  $V_{DD} = 5$  V
  - 2 V at  $V_{DD} = 10$  V
  - 2.5 V at  $V_{DD} = 15$  V
- 5-V, 10-V, and 15-V parametric ratings
- Meets all requirements of JEDEC Tentative Standard No. 13A, "Standard Specifications for Description of 'B' Series CMOS Devices"

### DESCRIPTION

The 4085 contains a pair of AND-OR-INVERT gates, each consisting of two 2-input AND gates driving a 3-input NOR gate. Individual inhibit controls are provided for both A-O-I gates.

The 4085B types are supplied in 14-lead dual-in-line ceramic packages (D and C suffixes), 14-lead dual-in-line plastic packages (E suffix), 14-lead ceramic flat packs (F suffix), and in chip form (H suffix).

### RECOMMENDED OPERATING CONDITIONS

For maximum reliability, nominal operating conditions should be selected so that operation is always within the following ranges:

CHARACTERISTIC	LIMITS		UNITS
	Min.	Max.	
Supply Voltage Range (For $T_A = \text{Full Package Temperature Range}$ )	3	18	V

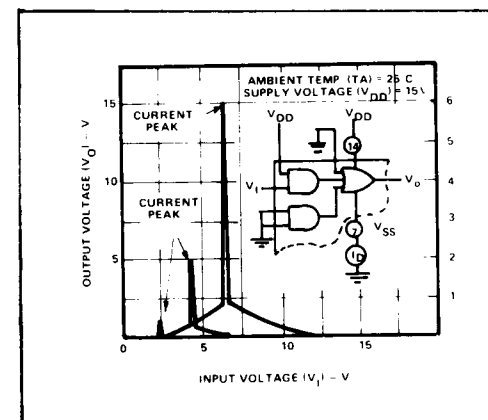
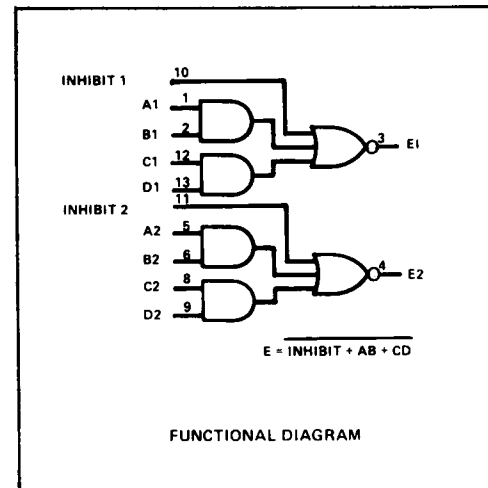
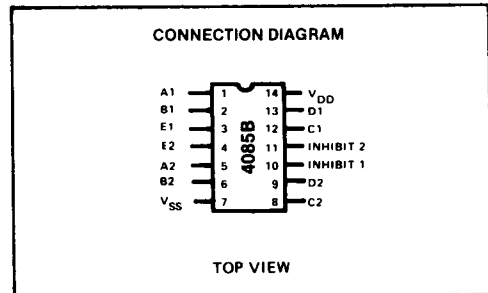

## ELECTRICAL CHARACTERISTICS

STATIC CHARACTERISTICS <sup>1</sup>

PARAMETER	V <sub>DD</sub> (V <sub>dC</sub> )	CONDITIONS	T <sub>LOW</sub> <sup>2</sup>		+25°C			T <sub>HIGH</sub> <sup>2</sup>		Units
			Min.	Max.	Min.	Typ.	Max.	Min.	Max.	
QUIESCENT DEVICE CURRENT	I <sub>DD</sub>	V <sub>IN</sub> = V <sub>SS</sub> or V <sub>DD</sub> All valid input combinations	—	0.05	—	0.0005	0.05	—	1.5	μA <sub>dC</sub>
			—	0.10	—	0.001	0.10	—	3.0	
			—	0.20	—	0.002	0.20	—	6.0	

NOTES: <sup>1</sup> Remaining Static Electrical Characteristics are listed under "4000B Series Family Specifications".

<sup>2</sup> T<sub>LOW</sub> = -55°C for C, D, F, H device.

= -40°C for E device.

T<sub>HIGH</sub> = +125°C for C, D, F, H device.

= + 85°C for E device.

## ABSOLUTE MAXIMUM RATINGS

DC SUPPLY-VOLTAGE RANGE, (V<sub>DD</sub>)

(Voltages referenced to V<sub>SS</sub> Terminal) . . . . . -0.5 to +20V

INPUT VOLTAGE RANGE,  
ALL INPUTS . . . . . -0.5 to V<sub>DD</sub> + 0.5V

DC INPUT CURRENT,  
ANY ONE INPUT . . . . . ±10 mA

POWER DISSIPATION PER PACKAGE (P<sub>D</sub>):  
For T<sub>A</sub> = -40 to +60°C  
(PACKAGE TYPE E) . . . . . 500 mW

For T<sub>A</sub> = +60 to +85°C

For T<sub>A</sub> = +60 to +85°C  
(PACKAGE TYPE E) . . . . . Derate Linearly  
at 12 mW/°C to 200 mW

For T<sub>A</sub> = -55 to +100°C  
(PACKAGE TYPES D, F, C) . . . . . 500 mW

For T<sub>A</sub> = +100 to +125°C  
(PACKAGE TYPES D, F, C) . Derate Linearly  
at 12 mW/°C to 200 mW

DEVICE DISSIPATION  
PER OUTPUT TRANSISTOR

For T<sub>A</sub> = FULL PACKAGE-TEMPERATURE  
RANGE (All Package Types) . . . . . 100 mW

OPERATING TEMPERATURE RANGE (T<sub>A</sub>):  
PACKAGE TYPES D, F, C, H . -55 to +125°C  
PACKAGE TYPE E . . . . . -40 to +85°C

STORAGE TEMPERATURE  
RANGE (T<sub>stg</sub>) . . . . . -65 to +150°C

## LEAD TEMPERATURE (DURING SOLDERING):

At distance 1/16 ± 1/32 inch (1.59 ± 0.79mm)  
from case for 10 s max. . . . . +265°C

## DYNAMIC ELECTRICAL CHARACTERISTICS

(T<sub>A</sub> = 25°C, Input t<sub>r</sub>, t<sub>f</sub> = 20 ns, C<sub>L</sub> = 50pF, R<sub>L</sub> = 200 KΩ)

CHARACTERISTICS	CONDITIONS		LIMITS		UNITS
	V <sub>DD</sub> V	V	Typ	Max	
Propagation Delay Time (Data) High-to-Low Level	t <sub>PHL</sub>	5	225	450	ns
		10	90	180	
		15	65	130	
Low-to-High Level	t <sub>PLH</sub>	5	310	620	ns
		10	125	250	
		15	90	180	
Propagation Delay Time (Inhibit) High-to-Low Level	t <sub>PHL</sub>	5	150	300	ns
		10	60	120	
		15	40	80	
Low-to-High Level	t <sub>PLH</sub>	5	250	500	ns
		10	100	200	
		15	70	140	
Transition Time t <sub>THL</sub> , t <sub>TLH</sub>	t <sub>THL</sub> , t <sub>TLH</sub>	5	100	200	ns
		10	50	100	
		15	40	80	
Input Capacitance	C <sub>IN</sub>	Any Input	5	7.5	pF

