



# Series 513 LO-PRO® file Collet Sockets with Solder Tail Pins

## FEATURES:

- LO-PRO® file Collet Sockets are available with solder tail or wire wrap pins. Consult Data Sheet No. 12012 for wire wrap pins.
- Choose from several size and plating options.

## SPECIFICATIONS:

- Body material is black UL 94-HB Glass-filled Nylon. Hi-Temp body material is black UL 94V-0 4/6 Nylon.
  - Pin body is Brass Alloy 360 1/2 hard per UNS C36000 ASTM-B16-85.
  - Pin body plating is either 200µ [5.08µm] min. 93/7 Tin/Lead per MIL-P-81728 or 10µ [.025µm] min. Gold per MIL-G-45204 over 100µ [2.54µm] min. Nickel per QQ-N-290.
  - 4-fingered collet contact is Beryllium Copper Alloy per UNS C17200 ASTM-B194-92.
  - Contact plating is either 10µ [.25µm] Gold per MIL-G-45204 or 150µ [3.81µm] min. 93/7 Tin/Lead per MIL-P-81728 over 50µ min. [1.27µm] Nickel per QQ-N-290. Heavy 30µ [.76µm] min. Gold on contact also available.
  - Contact current rating=3 Amps.
  - Insertion Force=180 grams/pin; Withdrawal Force=90 grams/pin; Normal Force=140 grams/pin; based on a .018 [.46] dia. test lead.
  - Operating temperature=221°F [105°C] Tin plating, =257°F [125°C] Gold plating.
  - Accepts leads .015-.025 [.38-.64] in diameter, .100-.146 [2.54-3.71] long.
- ## MOUNTING CONSIDERATIONS:
- Suggested PCB hole size=.030 ± .002 [.76 ± .05] dia.

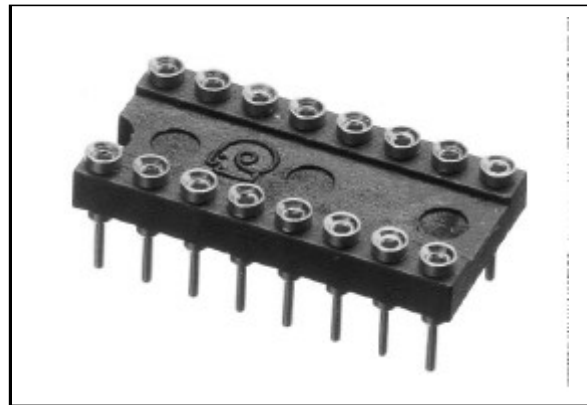

Note: Aries specializes in custom design and production. In addition to the standard products shown on this page, special materials, platings, sizes, and configurations can be furnished, depending on quantities. Aries reserves the right to change product specifications without notice.

## ORDERING INFORMATION

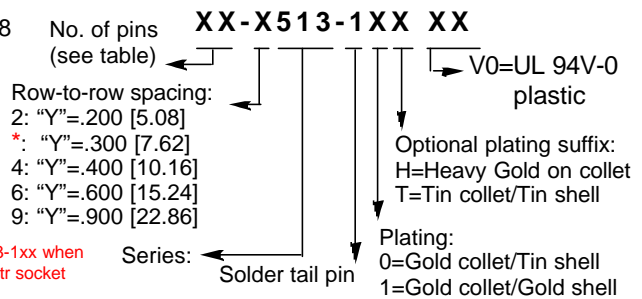

**ALL DIMENSIONS: INCHES [MILLIMETERS]**

\*use P/N xx-513-1xx when ordering .300 ctr socket

"W"=NO. OF PINS PER ROW X .100 [2.54]  
 "X"=(NO. OF PINS PER ROW - 1) X .100 [2.54]

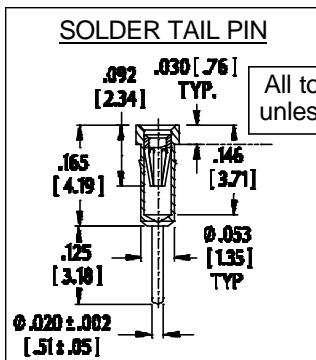

All tolerances ± .005 [.13] unless otherwise specified

Centers "Y"	Dim. "Z"	Body Style	Available Sizes
.200 [5.08]	.300 [5.08]	A	2 thru 10
.300 [7.62]	.400 [10.16]	C	2 thru 20
		B	22 thru 40
.400 [10.16]	.500 [12.70]	C	2 thru 22
.600 [15.24]	.700 [17.78]	C	2 thru 40
		B	42 thru 48
.900 [22.86]	1.000 [25.40]	B	2 thru 64

Consult Data Sheet No. 12012 for LO-PRO® file collet sockets with wire wrap pins.

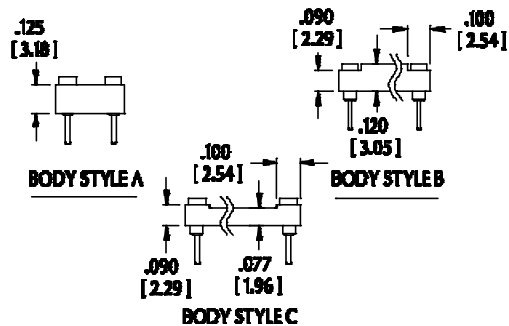
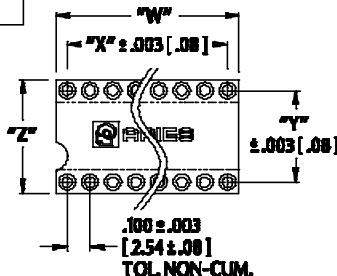

**ARIES**  
 ELECTRONICS, INC.  
<http://www.arieselec.com> • [info@arieselec.com](mailto:info@arieselec.com)

**NORTH AMERICA**  
 Frenchtown, NJ USA  
 TEL: (908) 996-6841  
 FAX: (908) 996-3891



**EUROPE**  
 TEL: +44 870 240 0249  
 FAX: +44 871 919 6033  
[europa@arieselec.com](mailto:europa@arieselec.com) 12011 REV.E