

- Rugged Triple-Diffused Planar Construction
- 2.5 A Continuous Collector Current
- Operating Characteristics Fully Guaranteed at 100°C
- 850 Volt Blocking Capability
- 50 W at 25°C Case Temperature

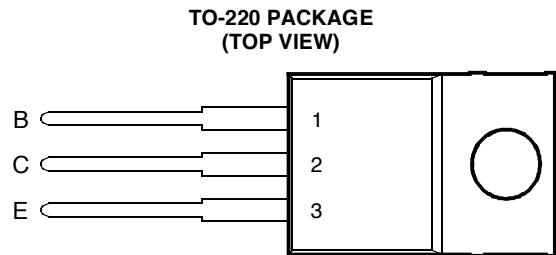

This series is currently available, but not recommended for new designs.



Pin 2 is in electrical contact with the mounting base.

MDTRACA

**absolute maximum ratings at 25°C case temperature (unless otherwise noted)**

RATING	SYMBOL	VALUE	UNIT
Collector-base voltage ( $I_E = 0$ )	$V_{CBO}$	850	V
Collector-emitter voltage ( $V_{BE} = 0$ )	$V_{CES}$	850	V
Collector-emitter voltage ( $I_B = 0$ )	$V_{CEO}$	400	V
Emitter-base voltage	$V_{EBO}$	10	V
Continuous collector current	$I_C$	2.5	A
Peak collector current (see Note 1)	$I_{CM}$	8	A
Continuous device dissipation at (or below) 25°C case temperature	$P_{tot}$	50	W
Operating junction temperature range	$T_j$	-65 to +150	°C
Storage temperature range	$T_{stg}$	-65 to +150	°C

NOTE 1: This value applies for  $t_p \leq 10$  ms, duty cycle  $\leq 2\%$ .

**PRODUCT INFORMATION**

MARCH 1984 - REVISED SEPTEMBER 2002  
Specifications are subject to change without notice.

**electrical characteristics at 25°C case temperature (unless otherwise noted)**

PARAMETER	TEST CONDITIONS	MIN	TYP	MAX	UNIT
$V_{CE(sus)}$ Collector-emitter sustaining voltage	$I_C = 100 \text{ mA}$ $L = 25 \text{ mH}$ (see Note 2)	400			V
$I_{CES}$ Collector-emitter cut-off current	$V_{CE} = 850 \text{ V}$ $V_{BE} = 0$ $V_{CE} = 850 \text{ V}$ $V_{BE} = 0$ $T_C = 100^\circ\text{C}$			5 200	$\mu\text{A}$
$I_{CEO}$ Collector cut-off current	$V_{CE} = 400 \text{ V}$ $I_B = 0$			5	$\mu\text{A}$
$I_{EBO}$ Emitter cut-off current	$V_{EB} = 10 \text{ V}$ $I_C = 0$			1	mA
$h_{FE}$ Forward current transfer ratio	$V_{CE} = 5 \text{ V}$ $I_C = 0.5 \text{ A}$ (see Notes 3 and 4)	20		60	
$V_{CE(sat)}$ Collector-emitter saturation voltage	$I_B = 0.2 \text{ A}$ $I_C = 1 \text{ A}$ (see Notes 3 and 4) $I_B = 0.5 \text{ A}$ $I_C = 2.5 \text{ A}$ $I_B = 0.5 \text{ A}$ $I_C = 2.5 \text{ A}$ $T_C = 100^\circ\text{C}$			1.0 2.5 5.0	V
$V_{BE(sat)}$ Base-emitter saturation voltage	$I_B = 0.2 \text{ A}$ $I_C = 1 \text{ A}$ (see Notes 3 and 4) $I_B = 0.5 \text{ A}$ $I_C = 2.5 \text{ A}$ $I_B = 0.5 \text{ A}$ $I_C = 2.5 \text{ A}$ $T_C = 100^\circ\text{C}$			1.0 1.2 1.3	V
$f_t$ Current gain bandwidth product	$V_{CE} = 10 \text{ V}$ $I_C = 0.5 \text{ A}$ $f = 1 \text{ MHz}$		12		MHz
$C_{ob}$ Output capacitance	$V_{CB} = 20 \text{ V}$ $I_E = 0$ $f = 0.1 \text{ MHz}$		55		pF

- NOTES: 2. Inductive loop switching measurement.  
3. These parameters must be measured using pulse techniques,  $t_p = 300 \mu\text{s}$ , duty cycle  $\leq 2\%$ .  
4. These parameters must be measured using voltage-sensing contacts, separate from the current carrying contacts.

**thermal characteristics**

PARAMETER	MIN	TYP	MAX	UNIT
$R_{\theta JC}$ Junction to case thermal resistance			2.5	$^\circ\text{C/W}$

**inductive-load-switching characteristics at 25°C case temperature (unless otherwise noted)**

PARAMETER	TEST CONDITIONS †	MIN	TYP	MAX	UNIT
$t_{sv}$ Voltage storage time	$I_C = 2.5 \text{ A}$ $I_{B(on)} = 0.5 \text{ A}$ (see Figures 1 and 2) $V_{BE(off)} = -5 \text{ V}$			2	$\mu\text{s}$
$t_{rv}$ Voltage rise time				200	ns
$t_{fi}$ Current fall time				200	ns
$t_{ti}$ Current tail time				50	ns
$t_{xo}$ Cross over time				300	ns
$t_{sv}$ Voltage storage time	$I_C = 2.5 \text{ A}$ $I_{B(on)} = 0.5 \text{ A}$ (see Figures 1 and 2) $V_{BE(off)} = -5 \text{ V}$ $T_C = 100^\circ\text{C}$			2.5	$\mu\text{s}$
$t_{rv}$ Voltage rise time				400	ns
$t_{fi}$ Current fall time				250	ns
$t_{ti}$ Current tail time				50	ns
$t_{xo}$ Cross over time				500	ns

† Voltage and current values shown are nominal; exact values vary slightly with transistor parameters.

**PARAMETER MEASUREMENT INFORMATION**

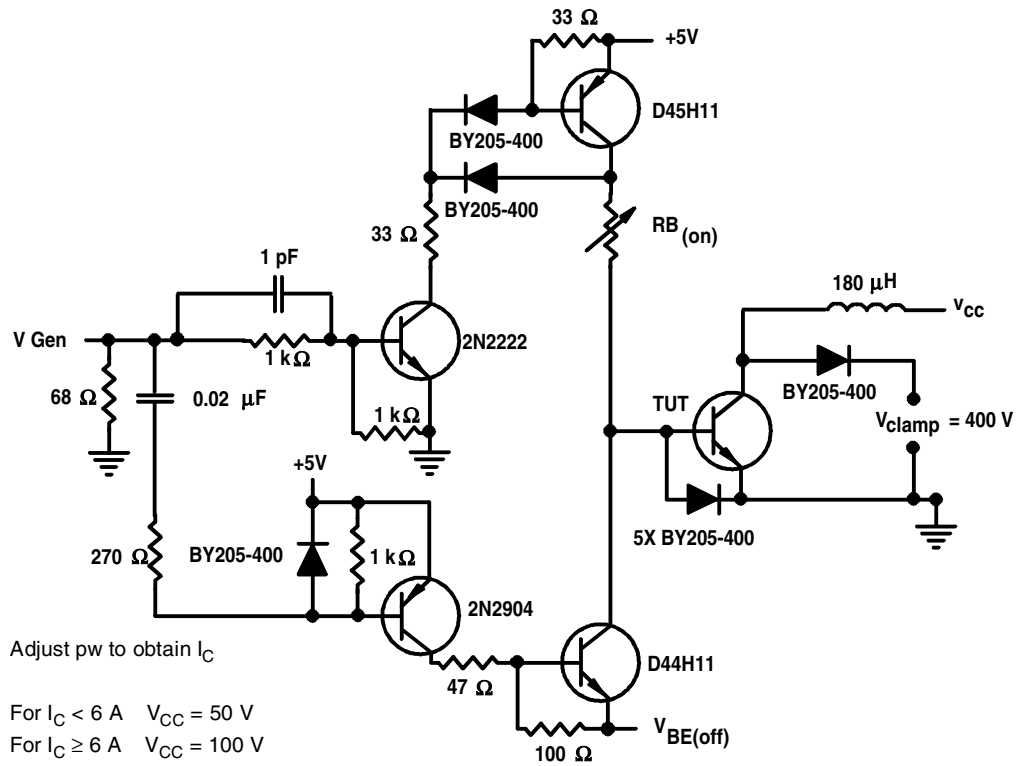

**Figure 1. Inductive-Load Switching Test Circuit**

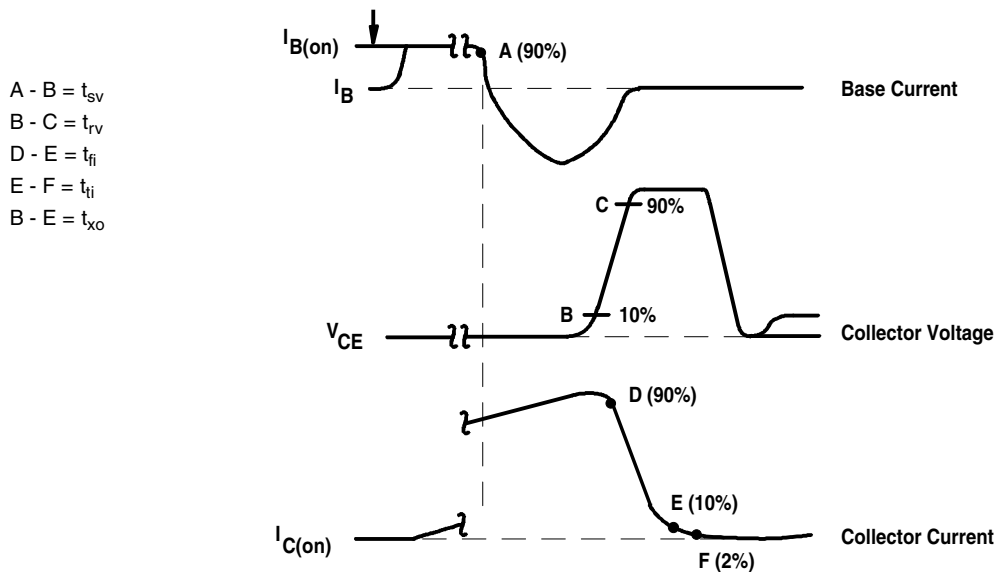

NOTES: A. Waveforms are monitored on an oscilloscope with the following characteristics:  $t_r < 15\text{ ns}$ ,  $R_{in} > 10\ \Omega$ ,  $C_{in} < 11.5\text{ pF}$ .  
 B. Resistors must be noninductive types.

**Figure 2. Inductive-Load Switching Waveforms**

**PRODUCT INFORMATION**

TYPICAL CHARACTERISTICS

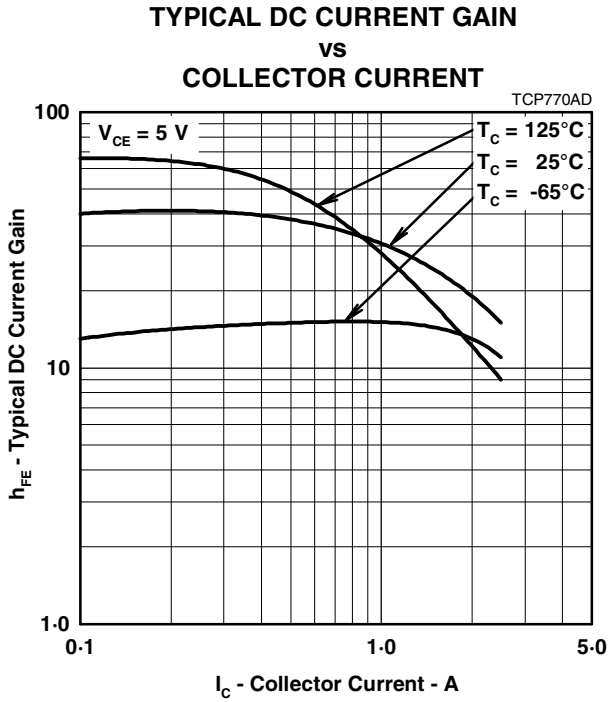

Figure 3.

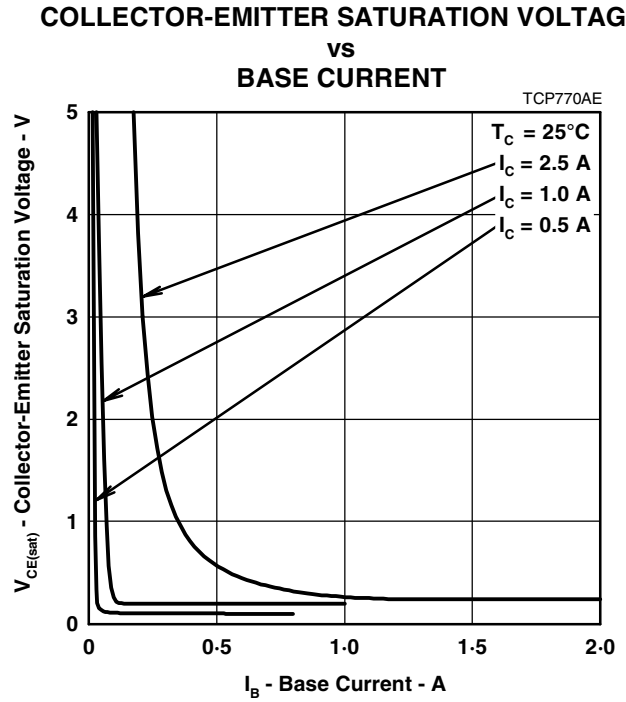

Figure 4.

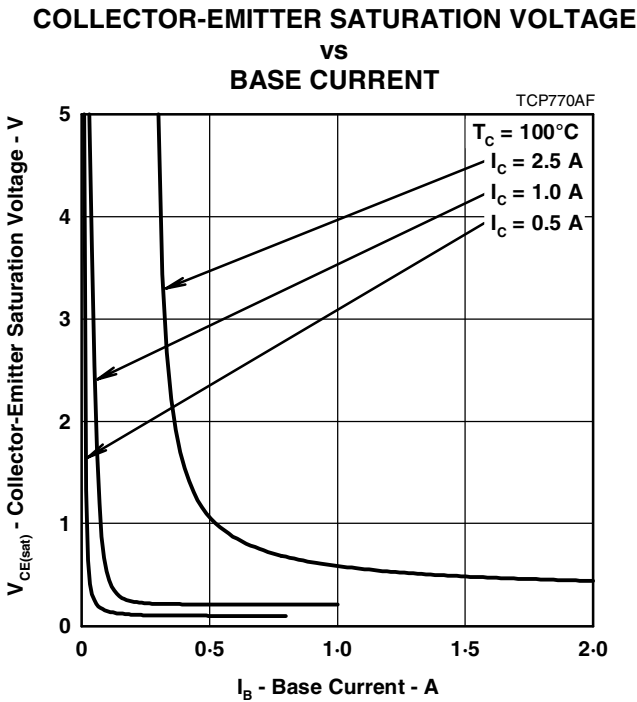

Figure 5.

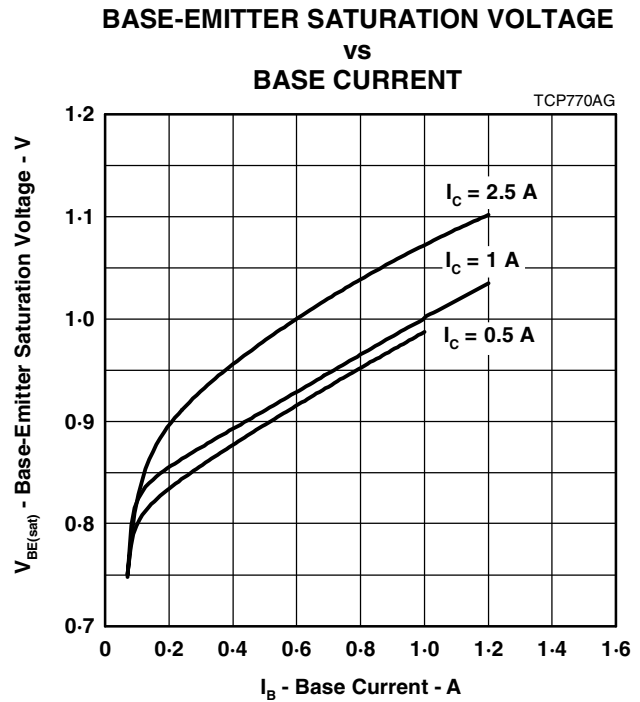
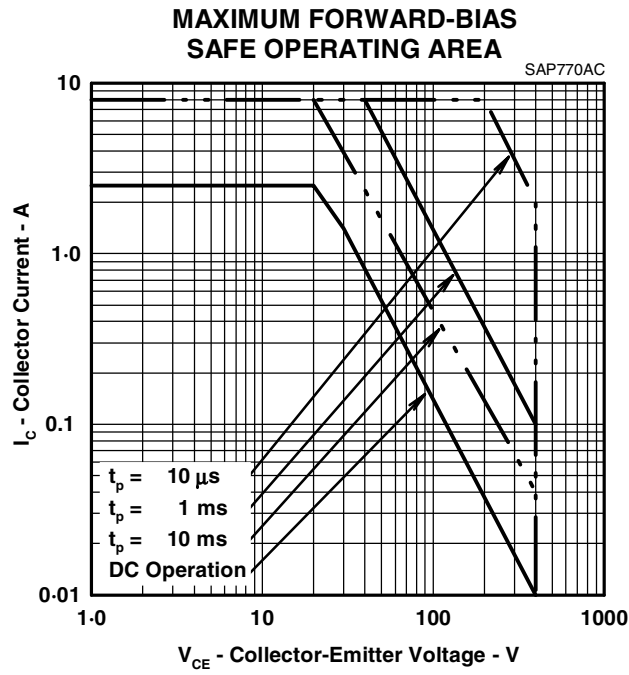

Figure 6.

**PRODUCT INFORMATION**

MARCH 1984 - REVISED SEPTEMBER 2002  
Specifications are subject to change without notice.

**MAXIMUM SAFE OPERATING REGIONS**



**PRODUCT INFORMATION**

MARCH 1984 - REVISED SEPTEMBER 2002  
Specifications are subject to change without notice.