

FEATURES

- CDMA/EVDO Compliant
- HELP™ technology
- High Efficiency (RC-1 waveform):
 - 36 % @ P_{OUT} = +28.0 dBm
 - 17 % @ P_{OUT} = +15.5 dBm
- Low Quiescent Current: 13 mA
- Low Leakage Current in Shutdown Mode: <6 μA
- Internal Voltage Regulator
- Integrated “daisy chainable” directional coupler with CPL_{IN} and CPL_{OUT} port.
- Internal DC Blocks on all RF ports
- Optimized for a 50 Ω System
- 1.8V Control Logic
- RoHS Compliant Package, 260 °C MSL-3

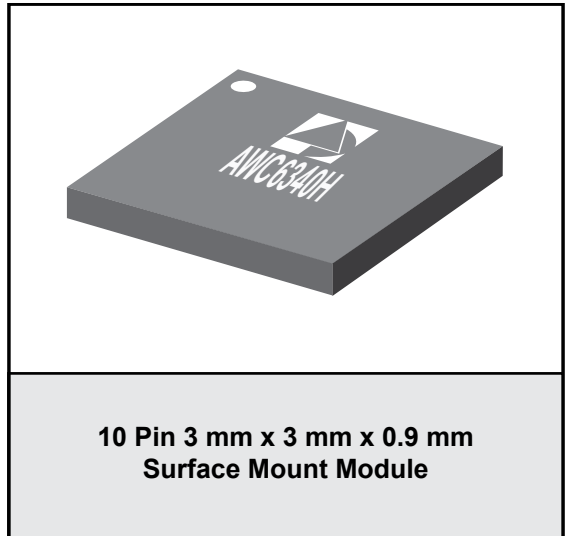

APPLICATIONS

- Band Class 0, 10 CDMA/EVDO Wireless Devices

PRODUCT DESCRIPTION

The AWC6340H is a HELP™ product for CDMA devices operating in Band Class 0 and 10. This PA incorporates ANADIGICS’ HELP™ technology to deliver exceptional efficiency at low power levels and low quiescent current without the need for external voltage regulators or converters. The device is manufactured using advanced InGaP HBT technology offering state-of-the-art reliability, temperature stability, and ruggedness. Two selectable bias modes that optimize efficiency for different output power levels and a shutdown mode with low leakage current increase handset talk and standby time. A “daisy chainable” directional coupler is integrated in the module thus eliminating the need of an external coupler. The self-contained 3 mm x 3 mm x 0.9 mm surface mount package incorporates matching networks optimized for output power, efficiency, and linearity in a 50 Ω system.

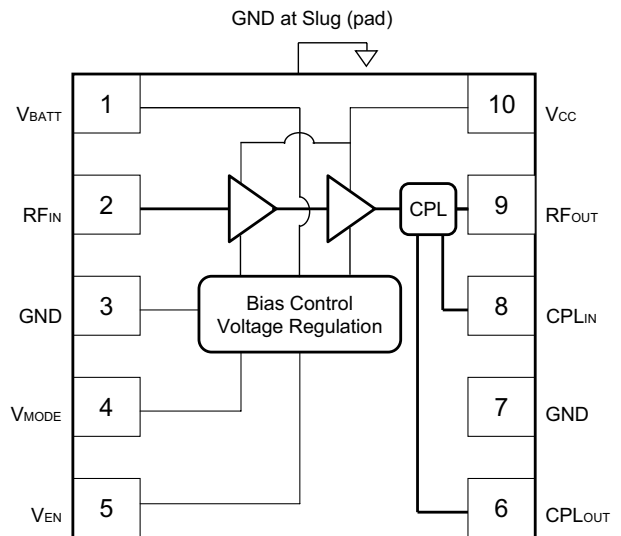

Figure 1: Block Diagram

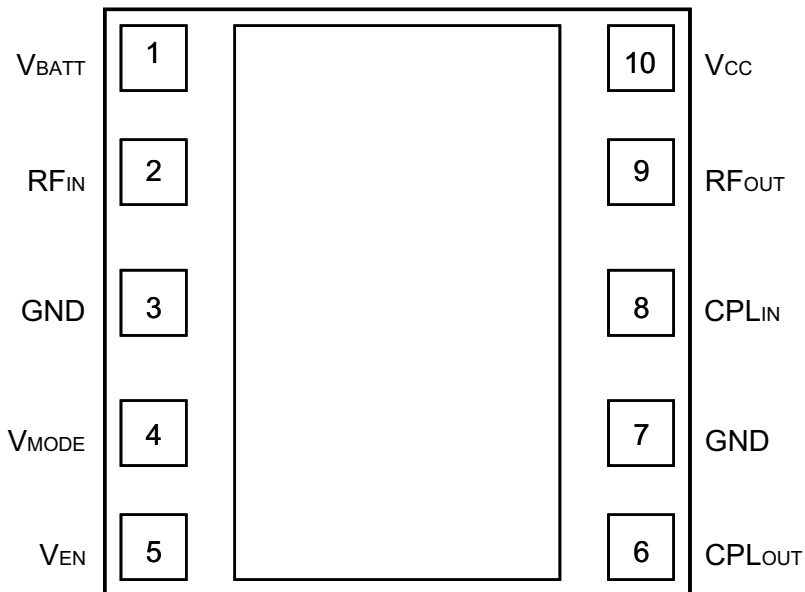

Figure 2: Pinout (X-ray Top View)

Table 1: Pin Description

PIN	NAME	DESCRIPTION
1	V _{BATT}	Battery Voltage
2	RF _{IN}	RF Input
3	GND	Ground
4	V _{MODE}	Mode Control Voltage
5	V _{EN}	PA Enable Voltage
6	CPL _{OUT}	Coupler Output
7	GND	Ground
8	CPL _{IN}	Coupler Input
9	RF _{OUT}	RF Output
10	V _{CC}	Supply Voltage

ELECTRICAL CHARACTERISTICS

Table 2: Absolute Minimum and Maximum Ratings

PARAMETER	MIN	MAX	UNIT
Supply Voltage (V_{CC})	0	+5	V
Battery Voltage (V_{BATT})	0	+6	V
Control Voltages (V_{MODE} , V_{EN})	0	+3.5	V
RF Input Power (P_{IN})	-	+10	dBm
Storage Temperature (T_{STG})	-40	+150	°C

Stresses in excess of the absolute ratings may cause permanent damage. Functional operation is not implied under these conditions. Exposure to absolute ratings for extended periods of time may adversely affect reliability.

Table 3: Operating Ranges

PARAMETER	MIN	TYP	MAX	UNIT	COMMENTS
Operating Frequency (f)	816	-	849	MHz	BC0, BC10
Supply Voltage (V_{CC})	+3.1	+3.4	+4.35	V	$P_{OUT} \leq +28$ dBm
Enable Voltage (V_{EN})	+1.35 0	+1.8 -	+3.1 +0.5	V	PA "on" PA "shut down"
Mode Control Voltage (V_{MODE})	+1.35 0	+1.8 -	+3.1 +0.5	V	Low Bias Mode High Bias Mode
CDMA Output Power					
HPM	27.5 ⁽¹⁾	28	-	dBm	BC0 CDMA 2000, RC1 BC10
HPM	26.9	27.7	-		
LPM	-	15.5	-		
Case Temperature (T_C)	-30	-	+90	°C	

The device may be operated safely over these conditions; however, parametric performance is guaranteed only over the conditions defined in the electrical specifications.

Note:

(1) For operation at 3.1 V, P_{OUT} is derated by 0.8 dB.

Table 4: Electrical Specifications - CDMA2000 Operation BC0 (RC-1 waveform)
(T_c = +25 °C, V_{BATT} = V_{CC} = +3.4 V, V_{ENABLE} = +1.8 V, 50 Ω system)

PARAMETER	MIN	TYP	MAX	UNIT	COMMENTS	
					P _{OUT}	V _{MODE}
Gain	25.5 13.5	28 16	31 20	dB	+28 dBm +15.5 dBm	0 V 1.8 V
Adjacent Channel Power at ±885 kHz offset ⁽¹⁾ Primary Channel BW = 1.23 MHz Adjacent Channel BW = 30 kHz	- -	-49 -54	-46 -46	dBc	+28 dBm +15.5 dBm	0 V 1.8 V
Adjacent Channel Power at ±1.98 MHz offset ⁽¹⁾ Primary Channel BW = 1.23 MHz Adjacent Channel BW = 30 kHz	- -	-59 -61	-56.5 -56.5	dBc	+28 dBm +15.5 dBm	0 V 1.8 V
Efficiency ⁽¹⁾	32 -	37 18	- -	%	+28 dBm +15.5 dBm	0 V 1.8 V
Quiescent Current (I _{cq}) Low Bias Mode	-	13	20	mA	through V _{CC} pin	1.8 V
Mode Control Current	-	0.06	0.15	mA	through V _{MODE} pin, V _{MODE} = 1.8 V	
Enable Current	-	0.06	0.15	mA	through V _{EN} pin, V _{MODE} = 1.8 V	
BATT Current	-	2.5	4.5	mA	through V _{BATT} pin, V _{MODE} = +1.8 V	
Leakage Current	-	6	15	μA	V _{BATT} = +4.35 V, V _{CC} = +4.35 V, V _{EN} = 0 V, V _{MODE} = 0 V	
Noise in Receive Band	-	-134	-	dBm/Hz		
Harmonic 2fo 3fo, 4fo	- -	-40 -50	- -	dBc	P _{OUT} ≤ +28 dBm	
Coupling Factor	-	20	-	dB		
Coupler IN_OUT Daisy Chain Insertion Loss	-	<0.25	-	dB	698 MHz to 2620 MHz Pin 8-6, Shutdown Mode	
Spurious Output Level (all spurious outputs)	-	-	-70	dBc	P _{OUT} ≤ +28 dBm In-band Load VSWR < 5:1 Out-of-band Load VSWR < 10:1 Applies over all operating conditions	
Load mismatch stress with no permanent degradation or failure	8:1	-	-	VSWR	Applies over all operating conditions	

Notes:

(1) ACLR and Efficiency measured at 836.5 MHz.

APPLICATION INFORMATION

To ensure proper performance, refer to all related Application Notes on the ANADIGICS web site: <http://www.anadigics.com>

The Bias Control table below lists the recommended modes of operation for various applications.

Shutdown Mode

The power amplifier may be placed in a shutdown mode by applying logic low levels (see Operating Ranges table) to the V_{EN} and V_{MODE} voltages.

Two operating modes are recommended to optimize current consumption. HighBias/High Power operating mode is for P_{out} levels >16 dBm. At about 16 dBm, the PA should be “Mode Switched” to Low Power Mode.

Bias Modes

The power amplifier may be placed in either Low or High Bias modes by applying the appropriate logic level (see Operating Ranges table) to the V_{MODE} pin.

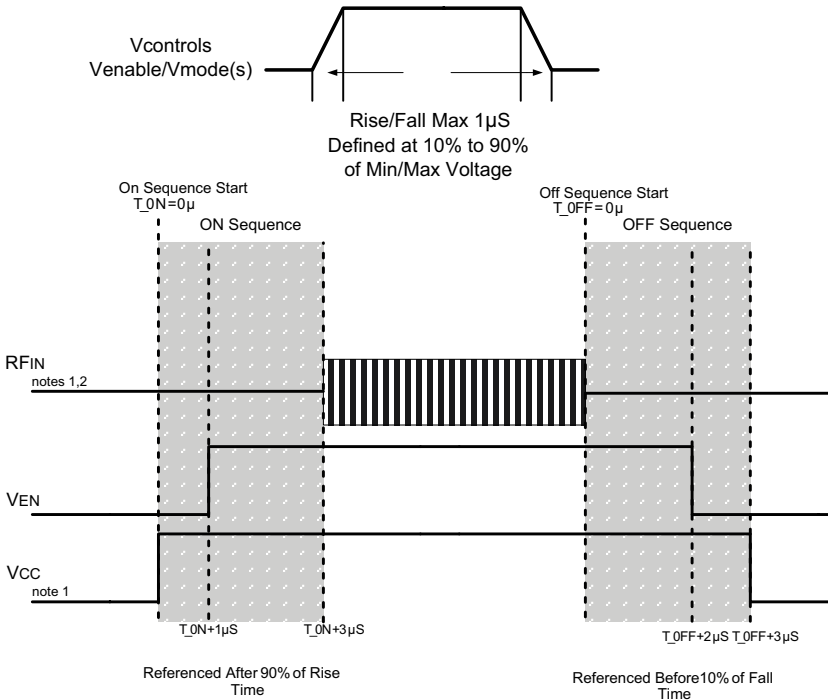

Figure 3: Recommended ON/OFF Timing Sequence

Notes:

- (1) Level might be changed after RF is ON.
- (2) RF OFF defined as $P_{IN} \leq -30$ dBm.
- (3) Switching simultaneously between V_{MODE} and V_{EN} is not recommended.

Table 5: Bias Control

APPLICATION	P_{OUT} LEVELS	BIAS MODE	V_{EN}	V_{MODE}	V_{CC}	V_{BATT}
Low power	$\leq +16$ dBm	Low	+1.8 V	+1.8 V	3.1 - 4.35 V	> 3.1 V
High power	> +16 dBm	High	+1.8 V	0 V	3.1 - 4.35 V	> 3.1 V
Shutdown	-	Shutdown	0 V	0 V	3.1 - 4.35 V	> 3.1 V

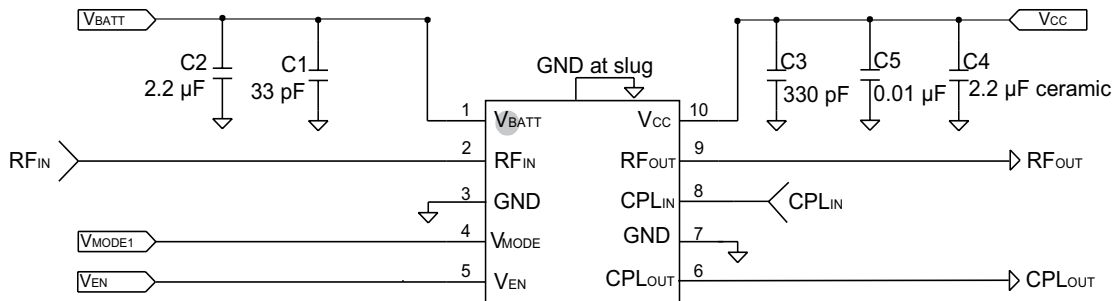
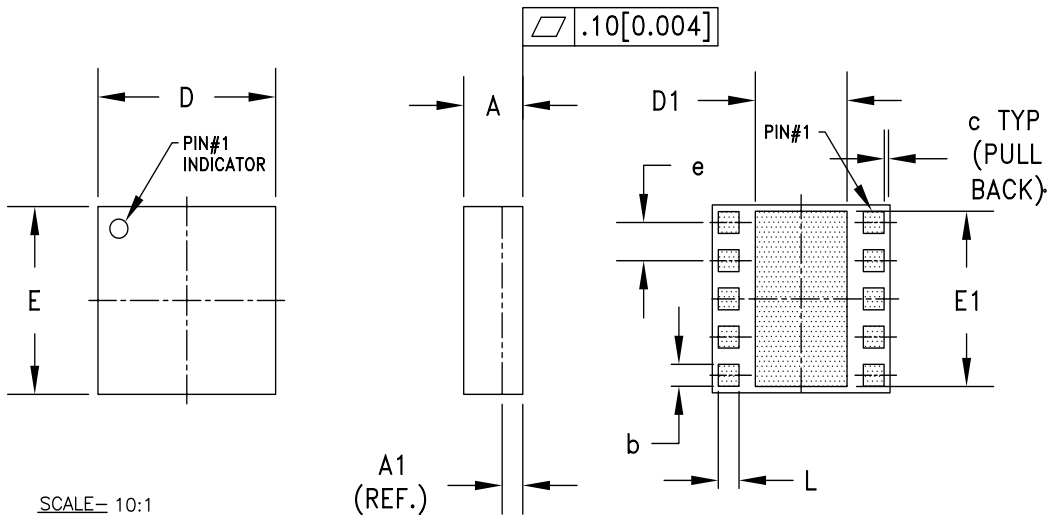

Figure 4: Evaluation Board Schematic

PACKAGE OUTLINE



SCALE= 10:1

SYMBOL	MILLIMETERS			INCHES			NOTE
	MIN.	NOM.	MAX.	MIN.	NOM.	MAX.	
A	0.88	0.94	1.00	0.035	0.037	0.039	-
A1	PLEASE REFER TO LAMINATE CONTROL DRAWING						-
b	0.32	0.35	0.40	0.013	0.014	0.016	3
c	-	0.10	-	-	0.004	-	-
D	2.88	3.00	3.12	0.113	0.118	0.123	-
D1	1.45	1.50	1.57	0.057	0.059	0.062	3
E	2.88	3.00	3.12	0.113	0.118	0.123	-
E1	2.70	2.75	2.85	0.106	0.108	0.112	3
e	0.60			0.024			3
L	0.32	0.35	0.40	0.013	0.014	0.016	3

NOTES:

1. CONTROLLING DIMENSIONS: MILLIMETERS
2. UNLESS SPECIFIED TOLERANCE=±0.076[0.003].
3. PADS (INCLUDING CENTER) SHOWN UNIFORM SIZE FOR REFERENCE ONLY. ACTUAL PAD SIZE AND LOCATION WILL VARY WITHIN MIN. AND MAX. DIMENSIONS ACCORDING TO SPECIFIC LAMINATE DESIGN.
4. UNLESS SPECIFIED DIMENSIONS ARE SYMMETRICAL ABOUT CENTER LINES SHOWN.
5. LAMINATE CONTROL DRAWING SPECIFIED BY PART NUMBER.

Figure 5: Package Outline - 10 Pin 3 mm x 3 mm x 0.9 mm Surface Mount Module

TOP BRAND

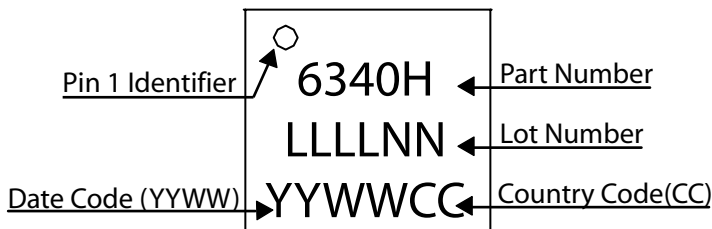
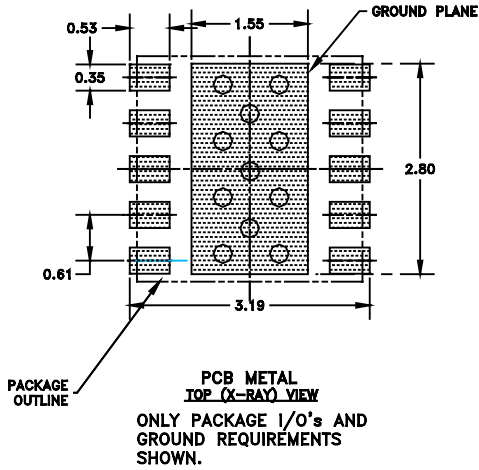

Figure 6: Branding Specification - M45 Package

PCB AND STENCIL DESIGN GUIDELINE



NOTES:

- (1) OUTLINE DRAWING REFERENCE: P8002478_E
- (2) UNLESS SPECIFIED DIMENSIONS ARE SYMMETRICAL ABOUT CENTER LINES SHOWN.
- (3) DIMENSIONS IN MILLIMETERS.
- (4) VIAS SHOWN IN PCB METAL VIEW ARE FOR REFERENCE ONLY. NUMBER & SIZE OF THERMAL VIAS REQUIRED DEPENDENT ON HEAT DISSIPATION REQUIREMENT AND THE PCB PROCESS CAPABILITY.
- (5) RECOMMENDED STENCIL THICKNESS: APPROX. 0.150mm (6 Mils)

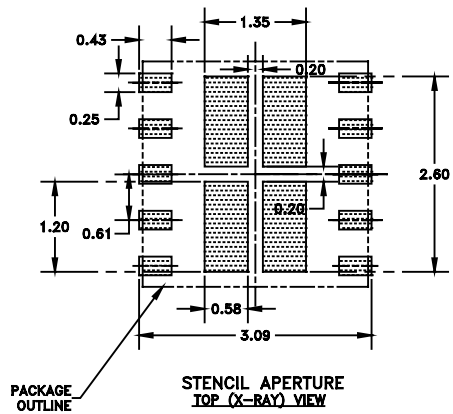
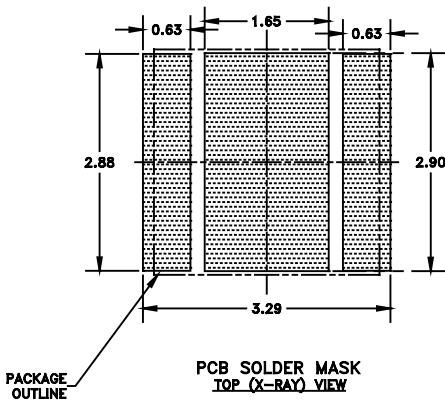

Figure 7: Recommended PCB Layout Information

ORDERING INFORMATION

ORDER NUMBER	TEMPERATURE RANGE	PACKAGE DESCRIPTION	COMPONENT PACKAGING
AWC6340HQ7	-30 °C to +90 °C	RoHS Compliant 10 Pin 3 mm x 3 mm x 0.9 mm Surface Mount Module	Tape and Reel, 2500 pieces per Reel
AWC6340HP9	-30 °C to +90 °C	RoHS Compliant 10 Pin 3 mm x 3 mm x 0.9 mm Surface Mount Module	Partial Tape and Reel



ANADIGICS

141 Mount Bethel Road
Warren, New Jersey 07059, U.S.A.
Tel: +1 (908) 668-5000
Fax: +1 (908) 668-5132

URL: <http://www.anadigics.com>

IMPORTANT NOTICE

ANADIGICS, Inc. reserves the right to make changes to its products or to discontinue any product at any time without notice. The product specifications contained in Advanced Product Information sheets and Preliminary Data Sheets are subject to change prior to a product's formal introduction. Information in Data Sheets have been carefully checked and are assumed to be reliable; however, ANADIGICS assumes no responsibilities for inaccuracies. ANADIGICS strongly urges customers to verify that the information they are using is current before placing orders.

WARNING

ANADIGICS products are not intended for use in life support appliances, devices or systems. Use of an ANADIGICS product in any such application without written consent is prohibited.