

# AN7356NSC

Recording and playback equalizer amp. IC for Hi-Fi cassette deck

## ■ Overview

The AN7356NSC is an audio signal processing IC for analog cassette deck. All the recording and playback processing can be realized with one chip.

## ■ Features

- Control various adjustment circuit by serial data
- Playback system
  - Built-in variable volume circuit ( $\pm 6$  dB) for playback gain adjustment
  - Built-in various equalizer switching circuit
  - Built-in series mute circuit
- Recording system
  - Built-in equalizer (freq. characteristics, gain) circuit of middle and high frequencies
  - Built-in volume circuit (+20 dB) for overall gain adjustment
  - With low frequency band boost pins
  - Built-in drive circuit for current output
- With parallel data output

## ■ Applications

- Cassette deck (Hi-Fi)

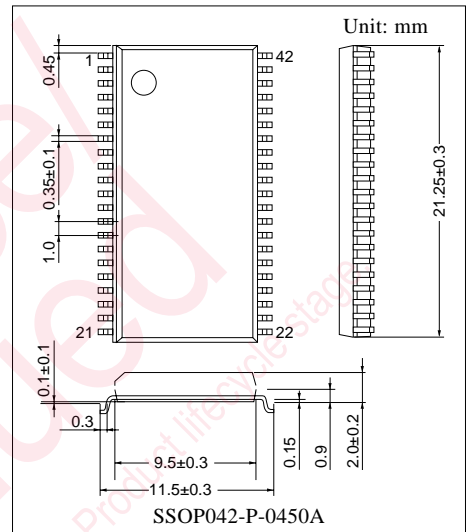

■ Block Diagram

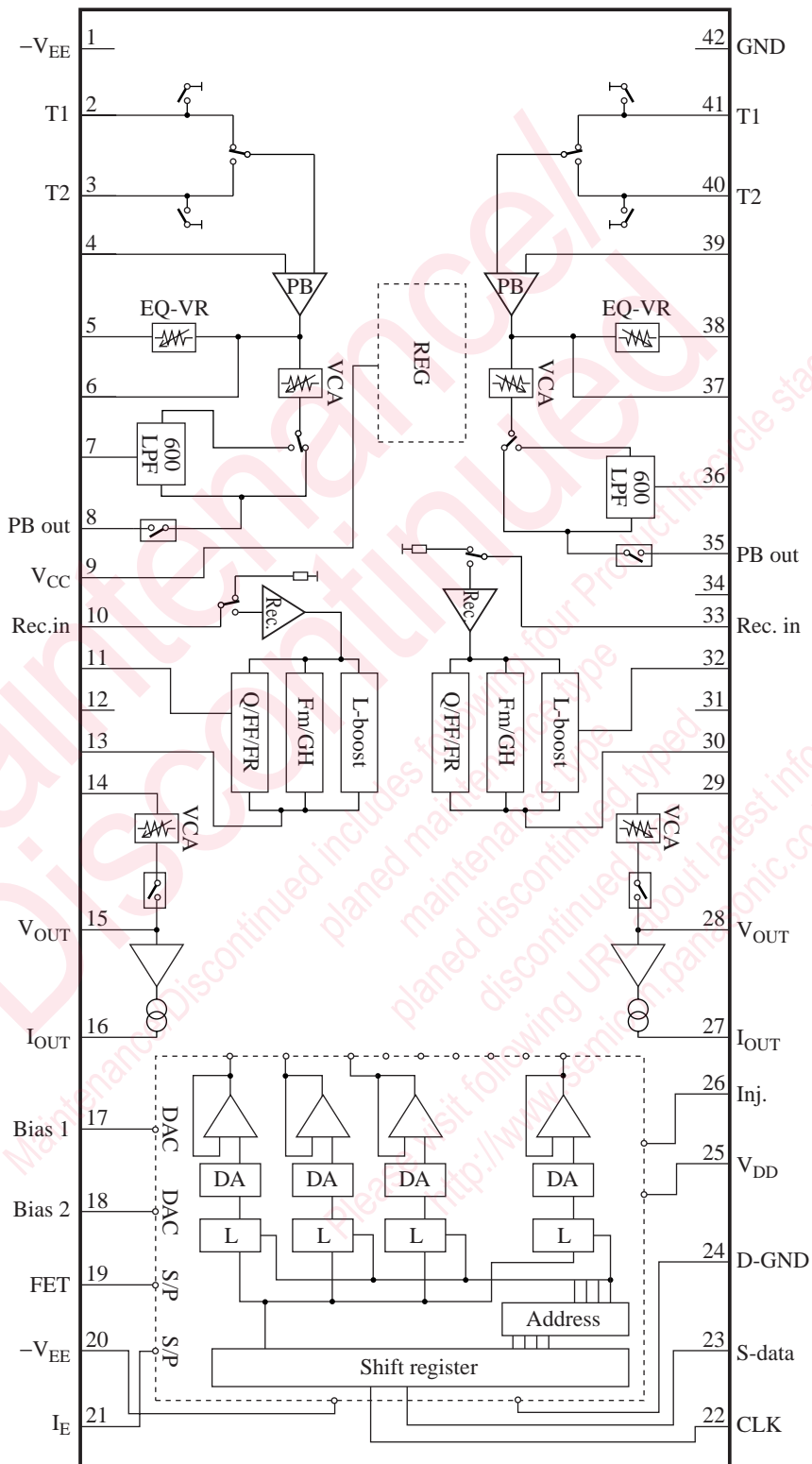

### ■ Pin Descriptions

Pin No.	Description	Pin No.	Description
1	Negative supply pin	22	Clock input
2	Playback amp. TAPE1 input	23	Serial data input
3	Playback amp. TAPE2 input	24	GND pin
4	Playback amp. negative feedback input	25	Positive supply pin
5	Playback amp. equalizer pin	26	Injector current pin
6	Playback amp. negative feedback output	27	Recording amp. current output
7	LPF pin	28	Recording amp. voltage output
8	Playback amp. output	29	Recording volume amp. input
9	Positive supply pin	30	Recording equalizer amp. output
10	Recording amp. non-inverting input	31	
11	Low frequency band boost pin	32	Low frequency band boost pin
12	DAC output pin(Addr.: 02)	33	Recording amp. non-inverting input
13	Recording equalizer amp. output	34	DAC calibration pin
14	Recording volume amp. input	35	Playback amp. output
15	Recording amp. voltage output	36	LPF pin
16	Recording amp. current output	37	Playback amp. negative feedback output
17	DAC output pin(Addr.: 0A)	38	Playback amp. equalizer pin
18	DAC output pin (Addr.: 09)	39	Playback amp. negative feedback input
19	FET drive current output	40	Playback amp. TAPE2 input
20	Negative supply pin	41	Playback amp. TAPE1 input
21	Erase current output	42	GND pin

### ■ Absolute Maximum Ratings

Parameter	Symbol	Rating	Unit
Supply voltage	$V_{CC}$	$\pm 7.7$	V
	$V_{DD}$	+7.7	
Supply current	$I_{CC}$	—	mA
Power dissipation *2	$P_D$	443	mW
Operating ambient temperature *1	$T_{opr}$	-25 to +75	°C
Storage temperature *1	$T_{stg}$	-55 to +150	°C

Note) \*1 : All items are at  $T_a = 25^\circ\text{C}$ , except for the operating ambient temperature and storage temperature.

\*2 : Power dissipation of the IC single unit at  $T_a = 75^\circ\text{C}$ . Use the IC under the conditions of not exceeding the allowable power dissipation curve.

### ■ Recommended Operating Range

Parameter	Symbol	Range	Unit
Supply voltage	$V_{CC}$	$\pm 4.5$ to $\pm 6.5$ (typ.) to $\pm 7.2$	V
	$V_{DD}$	4.5 to 5.0 to 5.5	

■ Electrical Characteristics at  $V_{CC} = \pm 6.5 \text{ V}$ ,  $T_a = 25^\circ\text{C}$

Parameter	Symbol	Conditions	Min	Typ	Max	Unit	Note	
Playback system		$V_{IN} = -56 \text{ dBV}$ , $f = 1 \text{ kHz}$ , $30 \text{ kHz LPF}$ on						
Reference output level (0 dB)	$V_1$	—	-3.4	-1.4	0.6	dBV	Data(1)	
Reference output level (+6 dB)	$G_H$	Difference between 6 dB and 0 dB $G_H = \text{data (2)} - \text{data (1)}$	5.0	6.0	7.0	dB	Data(2)	
Reference output level (-6 dB)	$G_L$	Difference between -6 dB and 6 dB $G_L = \text{data (2)} - \text{data (3)}$	10	11.8	13.5	dB	Data(3)	
Level difference between tapes	$\Delta G_{T12}$	Operation: The above reference output level ( $V_1$ ) difference between tapes	—	0	1	dB		
Total harmonic distortion (T1, 0 dB)	$\text{THD}_1$	$V_{IN} = -64 \text{ dBV}$ , $30 \text{ kHz LPF}$ on	—	0.12	0.4	%		
Total harmonic distortion (T2, 0 dB)	$\text{THD}_2$	$V_{IN} = -64 \text{ dBV}$ , $30 \text{ kHz LPF}$ on	—	0.12	0.4	%		
Output noise voltage (T1, 0 dB)	$V_{NO1}$	IHF-A, $R_g = 2.2 \text{ k}\Omega$	—	-69	-56	dBV		
Output noise voltage (T2, 0 dB)	$V_{NO2}$	IHF-A, $R_g = 2.2 \text{ k}\Omega$	—	-69	-56	dBV		
Maximum output level (0 dB)	$V_{OMX}$	$\text{THD} = 3\%$	2.0	3.6	—	dBV		
Cross talk (ch. R → ch. L)	$\text{CT}_1$	$R_g (\text{CH2}) = 220 \Omega$	60	—	—	dB		
Cross talk (ch. L → ch. R)	$\text{CT}_2$	$R_g (\text{CH1}) = 220 \Omega$	60	—	—	dB		
Output offset voltage (0 dB)	$V_{OFF}$	$R_g = 220 \Omega$	-450	—	+130	mV		
Mute attenuation (T2)	$G_{M0}$	DAC5 = (08)	60	—	—	dB		
Mute attenuation (T1)	$G_{M1}$	T2 mode	60	—	—	dB		
Mute attenuation (T2)	$G_{M2}$	T1 mode	60	—	—	dB		
Pulse noise voltage	$\Delta V_P$	$R_g = 2.2 \text{ k}\Omega$	—	0	9	mV		
EQ-VR (120 $\mu$ )	$V_{EQ120}$	$f = 10 \text{ kHz}$	-7.3	-5.3	-3.3	dBV	Data(17)	
EQ-VR (70 $\mu$ )	$G_{EQ70}$	$f = 10 \text{ kHz}$ $G_{EQ70} = \text{data (18)} - \text{data (17)}$	-5.0	-4.0	-3.0	dB	Data(18)	
EQ-VR (50 $\mu$ )	$G_{EQ50}$	$f = 10 \text{ kHz}$ $G_{EQ50} = \text{data (19)} - \text{data (17)}$	-8.5	-7.5	-6.5	dB	Data(19)	
600 Hz LPF (50 $\mu$ )	$G_{LPF}$	$f = 10 \text{ kHz}$ $G_{LPF} = \text{data (23)} - \text{data (19)}$	—	-25	-20	dB	Data(23)	
T1/T2 switching shock noise	$\Delta V_{T12}$	Operation: The above output offset voltage ( $V_{OFF}$ ) difference between tapes	-55	0	55	mV		
Recording system								
Reference output (EQ output)	$V_{EQ}$	$f_{IN} = 400 \text{ Hz}$ , $V_{IN} = 6 \text{ dBV}$	-3	-0.5	2.0	dBV		
Middle and high frequency gain	High	$G_{HH}$ $V(400 \text{ Hz}) = 0 \text{ dB}$	$f_{IN} = 10 \text{ kHz}$ $V_{IN} = -12 \text{ dBV}$	3.0	5.0	7.0	dB	Data(32H)
	Low	$\Delta G_{HL}$ $\Delta GHL = \text{data (32H)} - \text{data (32L)}$		10	13	15		Data(32L)
High frequency peak gain	High	$G_{PH}$ $V(400 \text{ Hz}) = 0 \text{ dB}$	$f_{IN} = 25 \text{ kHz}$ $V_{IN} = -30 \text{ dBV}$	18	21	22	dB	Data(33H)
	Low	$\Delta G_{PL}$ $\Delta GHL = \text{data (33H)} - \text{data (33L)}$		18	12	24		Data(33L)

**■ Electrical Characteristics at  $V_{CC} = \pm 6.5$  V,  $T_a = 25^\circ\text{C}$  (continued)**

Parameter	Symbol	Conditions	Min	Typ	Max	Unit	Note		
Recording system (continued)									
High frequency peak bandwidth (10 kHz output)	Wide	$G_{QW}$	$V(25\text{ kHz}) = 0\text{ dB}$	$f_{(\text{peak})} = 25\text{ kHz}$	2.7	4.7	6.7	dB	Data(34W)
	NAR	$\Delta G_{QL}$	$\Delta GHL = \text{data (34W)}$ $-\text{Data (34N)}$	$f = 35\text{ kHz}$ $V_{IN} = -18\text{ dBV}$	14	16	18		Data(34N)
High frequency peak frequency DAC control	High	$D_{fPH}$	$f_{IN} = 44\text{ kHz}$	$V_{IN} = -30\text{ dBV}$	(2D)	(30)	(3B)	—	
	Low	$D_{fPL}$	$f_{IN} = 11\text{ kHz}$		(0D)	(10)	(13)		
Volume amp. gain (VOL output)	High	$G_{TH}$	—	$V_{IN} = -18\text{ dBV}$ $f_{IN} = 1\text{ kHz}$ (VR input)	17	19	21	dB	Data(36H)
	Low	$\Delta G_{TL}$	$\Delta GTL = \text{data (36H)}$ $-\text{data (36L)}$		16.3	18.3	20.3		Data(36L)
Total harmonic distortion	VOL	$THD_{RV}$	$V_{IN} = -14\text{ dBV}$ $R_{LV} = 10\text{ k}\Omega$	$f_{IN} = 1\text{ kHz}$	—	0.3	0.8	%	
	CURR	$THD_{RC}$	$V_{IN} = -20\text{ dBV}$ $R_{LV} = 1\text{ k}\Omega$		—	0.3	0.8		
Maximum output voltage	VOL	$V_{O-RV}$	$R_{LV} = 10\text{ k}\Omega$	$f_{IN} = 1\text{ kHz}$ $THD = 3\%$	2.2	3.2	—	V[rms]	
	CURR	$V_{O-RC}$	$R_{LV} = 1\text{ k}\Omega$		1.0	1.5	—		
Output noise voltage (curr. output)		$V_{N-RC}$	$R_g = 0\ \Omega$ , $R_{LV} = 1\text{ k}\Omega$ IHF-A		—	0.45	2	mV[rms]	
Input muting attenuation (EQ output)		$IM_{EQ}$	$f_{IN} = 1\text{ kHz}$ , $V_{IN} = -6\text{ dBV}$		40	—	—	dB	
Output offset voltage (EQ output)		$V_{OF-EQ}$	—		-500	—	+900	mV	
Output offset voltage (curr. output)		$V_{OF-RC}$	—		-25	—	+25	$\mu\text{A}$	
Output muting attenuation (VOL output)		$OM_{RV}$	$f_{IN} = 1\text{ kHz}$ , $V_{IN} = 0\text{ dBV}$ DAC (GTL) = (10)		60	—	—	dB	
Pulse noise voltage (curr. output)		$V_{PN}(RC)$	$R_g = 0\ \Omega$		-9	—	+9	mV[p-0]	
Logic system									
Bias output (low)		$V_{BL}$	DAC09 = (00) DAC0A = (00)		-2.5	-1.9	1.5	V	DC voltage Data(45)
Bias control width		$\Delta V_{BH}$	DAC09 = (FF), DAC0A = (FF) Data(46)–data(45)		4.2	4.7	5.2	V	DC voltage Data(46)
Current consumption									
Analog + $V_{CC}$		$I_{VCC}$	Without input		21	28	34	mA	DC
Digital + $V_{DD}$		$I_{VDD}$	Without input		0.7	1.5	2.3	mA	DC
- $V_{EE}$		$I_{VEE}$	Without input		-40	-36	-31	mA	DC

■ Terminal Equivalent Circuits

Pin No.	Equivalent circuit	Description	Standard waveform
1	—	Negative supply pin  Main circuit ( $-V_{EE}$ ) (analog system)	DC -6.5 V
2		Playback amp. T1 in (R-ch.)  Playback amp. Tape1 input	DC 0 V  
3		Playback amp. T2 in (R-ch.)  Playback amp. Tape2 input	
4		Playback amp. NF in (R-ch.)  Playback amp. negative feedback input	DC 0 V
5		NF switch (R-ch.)  Playback amp. equalizer switching	DC 0 V  

■ Terminal Equivalent Circuits (continued)

Pin No.	Equivalent circuit	Description	Standard waveform
6		<p>Playback amp. NF out (R-ch.)</p> <p>Playback amp. negative feedback output</p>	<p>DC 0 V</p>
7		<p>LPF-R</p> <p>600 Hz LPF</p>	<p>DC 0 V</p>
8		<p>Playback amp. out (R-ch.)</p> <p>Playback amp. output</p>	<p>DC 0 V</p>
9	<p>—</p>	<p>Positive supply pin</p> <p>Main circuit (+V<sub>CC</sub>) (analog system)</p>	<p>DC 6.5 V</p>

■ Terminal Equivalent Circuits (continued)

Pin No.	Equivalent circuit	Description	Standard waveform
10		Rec. in(R)  Rec. amp. (non-inverted) input	DC 0 V  
11		Boost (R)  Low frequency boost	DC 0 V  
12		DM  DAC output (Medium cut-off frequency control)	DC 0 V  
13		EQ out (R)  Rec. equalizer amp. output	DC 0 V  

■ Terminal Equivalent Circuits (continued)

Pin No.	Equivalent circuit	Description	Standard waveform
14		<p>VR in (R)</p> <p>Rec. volume amp. input</p>	<p>DC 0 V</p>
15		<p><math>V_{OUT(R)}</math></p> <p>Rec. amp. voltage output</p>	<p>DC 0 V</p>
16		<p><math>I_{OUT(R)}</math></p> <p>Rec. amp. current output</p>	
17		<p>Bias 1</p> <p>DAC output of address 0A</p>	<p>—</p>
18		<p>Bias 2</p> <p>DAC output of address 09</p>	

■ Terminal Equivalent Circuits (continued)

Pin No.	Equivalent circuit	Description	Standard waveform
19		FET FET drive current output	—
20	—	Supply pin Main circuit ( $-V_{EE}$ ) (digital system)	DC $-6.5$ V
21	Refer to pin 19	$I_E$ Erase current output	—
22		SCLK Clock input	DC 0 V
23		S-data Serial data input	
24	—	GND Main circuit (GND) (digital system)	DC 0 V
25	—	Supply pin Main circuit ( $+V_{DD}$ ) (digital system)	DC 5.0 V
26	—	Inj. $I^2L$ injector current pin Adjust the current by an external resistor	—

■ Terminal Equivalent Circuits (continued)

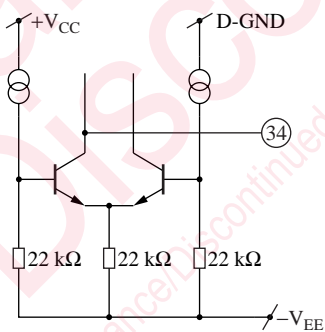
Pin No.	Equivalent circuit	Description	Standard waveform
27	Refer to pin 16	$I_{OUT(L)}$ Rec. amp. current output	Refer to pin 16
28	Refer to pin 15	$V_{OUT(L)}$ Rec. amp. voltage output	Refer to pin 15
29	Refer to pin 14	$V_R$ in (L) Rec. volume amp. input	Refer to pin 14
30	Refer to pin 13	EQ out (L) Rec. equalizer amp. output	Refer to pin 13
31	—	N.C.	—
32	Refer to pin 11	Boost (L) Low frequency boost	Refer to pin 11
33	Refer to pin 10	Rec in (L) Rec. amp. (non-inverting) input	Refer to pin 10
34		ID For DAC calibration	—
35	Refer to pin 8	Playback amp. out (L-ch.) Playback amp. output	Refer to pin 8
36	Refer to pin 7	LPF-L 600 Hz LPF	Refer to pin 7
37	Refer to pin 6	Playback amp. NF out (L-ch.) Playback amp. negative feedback output	Refer to pin 6

### ■ Terminal Equivalent Circuits (continued)

Pin No.	Equivalent circuit	Description	Standard waveform
38	Refer to pin 5	NF switch (L-ch.) Playback amp. equalizer switching	Refer to pin 5
39	Refer to pin 4	Playback amp. NF in (L-ch.) Playback amp. negative feedback input	Refer to pin 4
40	Refer to pin 3	Playback amp. T2 in (L-ch.) Playback amp. Tape2 input	Refer to pin 3
41	Refer to pin 2	Playback amp. T1 in (L-ch.) Playback amp. Tape1 input	Refer to pin 2
42	—	GND Main circuit (GND) (analog system)	DC 0 V

Note) Above are typical values and may change by applied condition and dispersion etc. ( $V_{CC} = \pm 6.5 V$ )

### ■ Technical Information

#### • Data specification description

##### 1. Data construction

bit No.	01	02	03	04	05	06	07	08	09	10	11	12	13	14	15	16	Control contents
Data construction	0	0	0	0	0	Data								0	0	1	Built-in switch over
		DAC address				DAC data								1	1		Built-in DAC

D/S: Data select

LD: Load

■ Technical Information (continued)

• Data specification description (continued)

2. Data communication system

2-wire system of Clock, Data

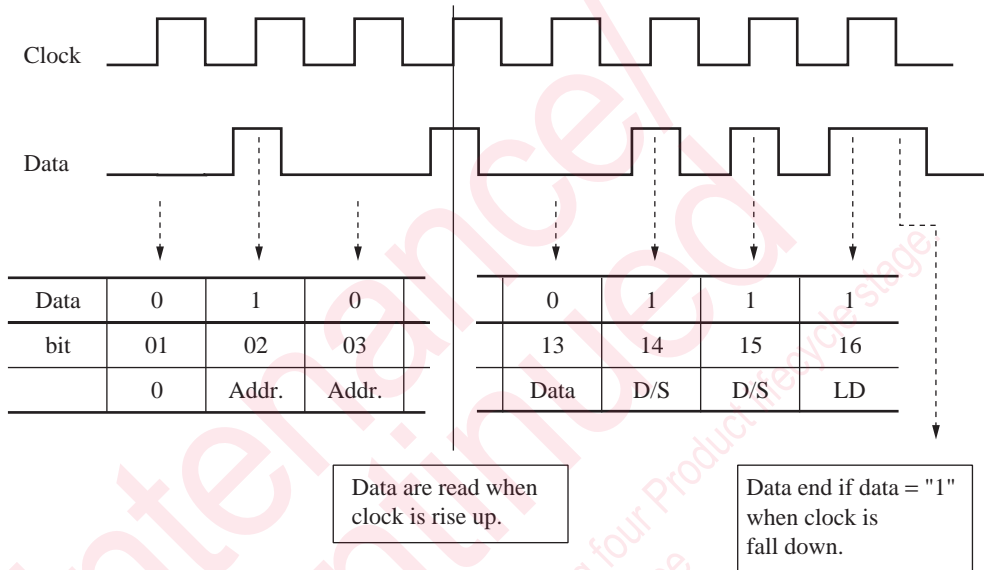

Transmit the empty data(0) of over the 5 clock between data when transmit data continuously.

3. Data timing, switching Characteristics

1) Data timing

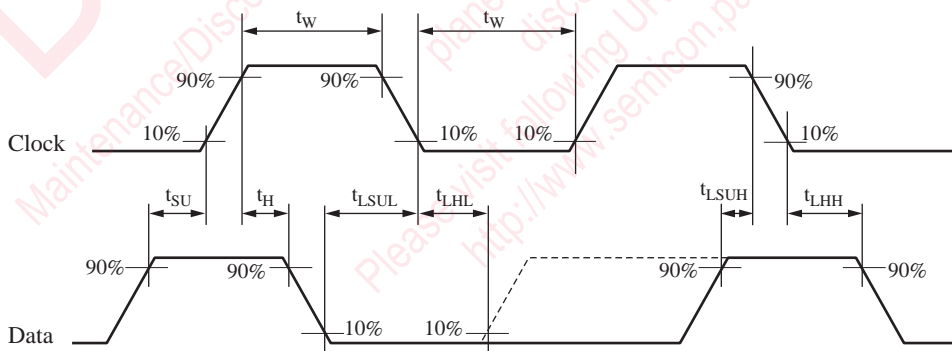

## ■ Technical Information (continued)

### • Data specification description (continued)

#### 3. Data timing, switching characteristics (continued)

##### 2) Switching characteristics

Parameter	Symbol	Rating			Unit	Condition
		Min	Typ	Max		
Minimum clock pulse width	$t_w$	5	—	—	$\mu\text{s}$	—
Data shift set-up time	$t_{\text{SU}}$	3	—	—	$\mu\text{s}$	—
Data shift hold time	$t_{\text{H}}$	3	—	—	$\mu\text{s}$	—
Data latch set-up time	$t_{\text{LSUH}}$	3	—	—	$\mu\text{s}$	—
Data latch hold time	$t_{\text{LHH}}$	3	—	—	$\mu\text{s}$	—
Data latch L set-up time	$t_{\text{LSUL}}$	3	—	—	$\mu\text{s}$	—
Data latch L hold time	$t_{\text{LHL}}$	3	—	—	$\mu\text{s}$	—

#### 4. Data format

##### 1) Built-in switch

bit No.	06	07	08	09	10	11	12	13	D/S
Item	120 $\mu$ /70 $\mu$	$\times 1/\times 2$	T1/T2	ARM	Rec. play	Stop	PB-adj.	$I_E$	0 0
0	70 $\mu$	$\times 2$	T2	On*	Play*	On*	Off	Off	
1	120 $\mu$	$\times 1$	T1	Off	Rec.	Off	On	On	

Note) \*: Initial setting is performed when supply turns on

##### 2) Built-in DAC

Addr.	06	07	08	09	10	11	12	13	D/S	
(00)	/		(00) to (20)* to (3F): FP (peak frequency characteristics)							1 1
(01)			(00) to (08)* to (10): Q (peak Q)							
(02)	/		(00) to (08)* to (10): FM (middle frequency characteristics)							
(03)			(00) to (20)* to (3F): GP (peak gain)							
(04)	/		(00) to (20)* to (3F): GM (middle frequency gain)							
(05)			(00)* to (20) to (3F): GPB-R(playback gain R-ch.)							
(06)	/		(00)* to (20) to (3F): GPB-L(playback gain L-ch.)							
(07)			(00)* to (80) to (FF): GT-R (recording gain R-ch.)							
(08)	(00)* to (80) to (FF): GT-L (recording gain L-ch.)									
(09)	(00)* to (80) to (FF): Bias-2 (bias)									
(0A)	(00)* to (80) to (FF): Bias-1 (bias)									
(MSB)			(LSB)							

Note) 1. \*: Initial setting is performed when supply turns on

2. Inside ( ) are indicated hexadecimal number

■ Technical Information (continued)

• Data specification description (continued)

5. Built-in switch mode table

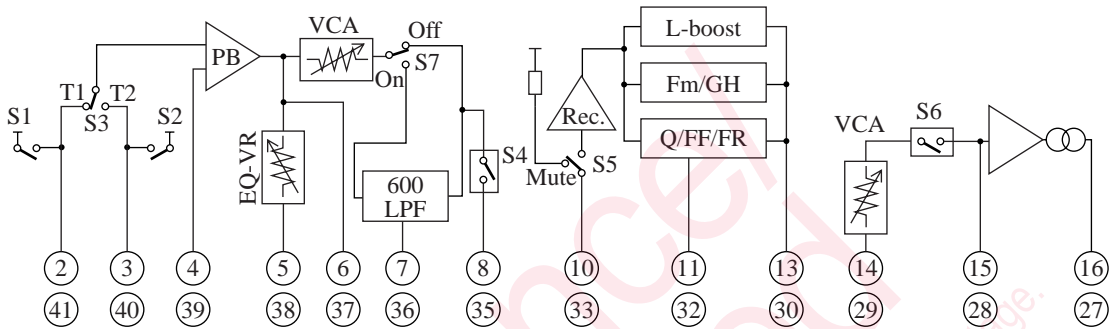

11	10	09	08	Input		Output	S1	S2	S3	S4	S5
STOP	R/P	ARM	T1/T2	PB	Rec.	PB	T1 input	T2 input	T1/T2	PB	Rec. input
				T1	T2		Mute	Mute	change-over	output	Mute
Off: 1	Rec.: 1	Off: 1	T1: 1				Mute: 1	Mute: 1	*T2: 1	Mute: 0	Off: 0
		On: 0	T1: 1			●					Mute: 1
	Play: 0	Off: 1	T1: 1	●	●	●	Off: 0	Mute: 1	T1: 0	On: 1	Off: 0
		On: 0	T1: 1	●	●	●	Off: 0	Mute: 1	T1: 0		Mute: 1
On: 0	Rec.: 1	Off: 1	T1: 1				Mute: 1	Mute: 1	*T2: 1	Mute: 0	Off: 0
		On: 0	T1: 1								Mute: 1
	Play: 0	Off: 1	T1: 1								Off: 0
		On: 0	T1: 1		●						Mute: 1

Note) \*: Initial setting when supply on

①

DAC	S4
GPB-R	PB output
(10) to (3F)	On
(00) to (08)	Mute

Note) Inside ( ) indicates hexadecimal number

②

DAC	S6	P19
GTL	Rec output	FET
(30) to (FF)	On	Drive
(00) to (10)	Mute	Off

Note) Inside ( ) indicates hexadecimal number

③ LPF switch of playback system

12	S7
PB adj.	LPF
On	On
1	1
Off	Off
0	0

④ Erase current

13	P21
I <sub>E</sub>	I <sub>E</sub> drive
On	On
1	
Off	Off
0	

⑤ Equalizer volume switch-over of playback system

07	06	EQ		
×1/×2	120/70	50 μ	70 μ	120 μ
×1	120 μ: 1	0	0	1
1	70 μ: 0			
×2	120 μ: 1	0	1	0
0	70 μ: 0	1	0	0



## Request for your special attention and precautions in using the technical information and semiconductors described in this book

- (1) If any of the products or technical information described in this book is to be exported or provided to non-residents, the laws and regulations of the exporting country, especially, those with regard to security export control, must be observed.
- (2) The technical information described in this book is intended only to show the main characteristics and application circuit examples of the products, and no license is granted under any intellectual property right or other right owned by our company or any other company. Therefore, no responsibility is assumed by our company as to the infringement upon any such right owned by any other company which may arise as a result of the use of technical information described in this book.
- (3) The products described in this book are intended to be used for standard applications or general electronic equipment (such as office equipment, communications equipment, measuring instruments and household appliances).  
Consult our sales staff in advance for information on the following applications:
  - Special applications (such as for airplanes, aerospace, automobiles, traffic control equipment, combustion equipment, life support systems and safety devices) in which exceptional quality and reliability are required, or if the failure or malfunction of the products may directly jeopardize life or harm the human body.
  - Any applications other than the standard applications intended.
- (4) The products and product specifications described in this book are subject to change without notice for modification and/or improvement. At the final stage of your design, purchasing, or use of the products, therefore, ask for the most up-to-date Product Standards in advance to make sure that the latest specifications satisfy your requirements.
- (5) When designing your equipment, comply with the range of absolute maximum rating and the guaranteed operating conditions (operating power supply voltage and operating environment etc.). Especially, please be careful not to exceed the range of absolute maximum rating on the transient state, such as power-on, power-off and mode-switching. Otherwise, we will not be liable for any defect which may arise later in your equipment.
  - Even when the products are used within the guaranteed values, take into the consideration of incidence of break down and failure mode, possible to occur to semiconductor products. Measures on the systems such as redundant design, arresting the spread of fire or preventing glitch are recommended in order to prevent physical injury, fire, social damages, for example, by using the products.
- (6) Comply with the instructions for use in order to prevent breakdown and characteristics change due to external factors (ESD, EOS, thermal stress and mechanical stress) at the time of handling, mounting or at customer's process. When using products for which damp-proof packing is required, satisfy the conditions, such as shelf life and the elapsed time since first opening the packages.
- (7) This book may be not reprinted or reproduced whether wholly or partially, without the prior written permission of Matsushita Electric Industrial Co., Ltd.