

## 74AC/ACT11471

### Octal Transceiver/Register with Dual Enable; 3-State; INV

Objective Specification

#### ACL Products

#### FEATURES

- Combines '245 and '374 type functions in one chip
- 8-bit octal transceiver with D-type flip-flops
- 3-State buffers
- Output capability:  $\pm 24$  mA
- CMOS (AC) and TTL (ACT) voltage level inputs
- 50 $\Omega$  incident wave switching
- Center-pin  $V_{CC}$  and ground configuration to minimize high-speed switching noise
- $I_{CC}$  category: MSI

#### DESCRIPTION

The 74AC/ACT11471 high-performance CMOS devices combine very high speed and high output drive comparable to the most advanced TTL families.

The 74AC/ACT11471 Octal Transceiver/Register contains two sets of D-type flip-flops for temporary storage of data flowing in either direction. Dual Enable ( $\overline{E}_{AB}$ ,  $\overline{E}_{BA}$ ) and Output Enable ( $\overline{OE}_{AB}$ ,  $\overline{OE}_{BA}$ ) inputs are provided for each register to permit independent control of inputting and outputting in either direction of data flow.

#### GENERAL INFORMATION

SYMBOL	PARAMETER	CONDITIONS $T_A = 25^\circ\text{C}; \text{GND} = 0\text{V};$ $V_{CC} = 5.0\text{V}$	TYPICAL		UNIT
			AC	ACT	
$t_{PLH}/t_{PHL}$	Propagation delay $CP_{XX}$ to $\overline{A}_n$ or $\overline{B}_n$	$C_L = 50\text{pF}$	5.2	6.7	ns
$C_{PD}$	Power dissipation capacitance per register <sup>1</sup>	$f = 1\text{MHz};$ $C_L = 50\text{pF}$	Enabled 155	Disabled 160	pF
$C_{IN}$	Input capacitance	$V_i = 0\text{V}$ or $V_{CC}$	4.5	4.5	
$C_{IO}$	I/O capacitance	$V_{IO} = 0\text{V}$ or $V_{CC}$ ; Disabled	12.0	12.0	pF
$I_{LATCH}$	Latch-up current	Per Jeduc JC40.2 Standard 17	500	500	mA
$f_{MAX}$	Maximum clock frequency	$C_L = 50\text{pF}$	125	125	MHz

Note:

1.  $C_{PD}$  is used to determine the dynamic power dissipation ( $P_D$  in  $\mu\text{W}$ ):

$$P_D = C_{PD} \times V_{CC}^2 \times f_i + \sum (C_L \times V_{CC}^2 \times f_o)$$

$f_i$  = input frequency in MHz,  $C_L$  = output load capacitance in pF,

$f_o$  = output frequency in MHz,  $V_{CC}$  = supply voltage in V,

$\sum (C_L \times V_{CC}^2 \times f_o)$  = sum of outputs

#### ORDERING INFORMATION

PACKAGES	TEMPERATURE RANGE	ORDER CODE
28-pin plastic DIP (300mil-wide)	-40°C to +85°C	74AC11471N 74ACT11471N
28-pin plastic SO (300mil-wide)	-40°C to +85°C	74AC11471D 74ACT11471D

#### PIN CONFIGURATION

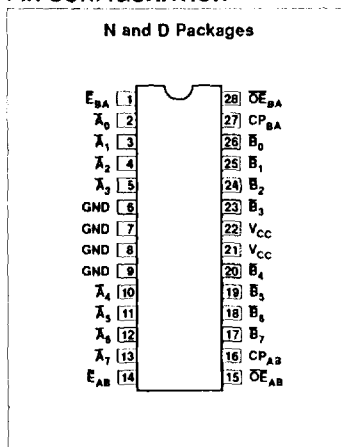

#### LOGIC SYMBOL

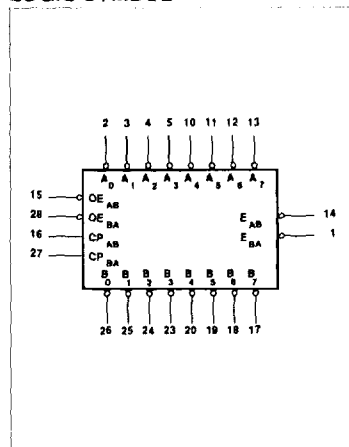

#### LOGIC SYMBOL (IEEE/IEC)

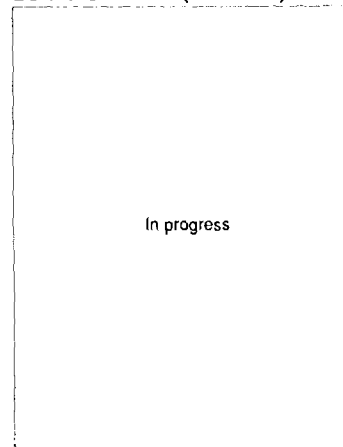

# Octal Transceiver/Register with Dual Enable; 3-State; INV

74AC/ACT11471

## PIN DESCRIPTION

PIN NUMBER	SYMBOL	NAME AND FUNCTION
16	$CP_{AB}$	A-to-B clock input (active Low)
27	$CP_{BA}$	B-to-A clock input (active Low)
15	$\overline{OE}_{AB}$	A-to-B output enable input (active Low)
28	$\overline{OE}_{BA}$	B-to-A output enable input (active Low)
14	$\overline{E}_{AB}$	A-to-B enable input (active Low)
1	$\overline{E}_{BA}$	B-to-A enable input (active Low)
2, 3, 4, 5, 10, 11, 12, 13	$\overline{A}_0 - \overline{A}_7$	Data inputs/outputs (A side)
26, 25, 24, 23, 20, 19, 18, 17	$\overline{B}_0 - \overline{B}_7$	Data inputs/outputs (B side)
6, 7, 8, 9	GND	Ground (0V)
21, 22	$V_{CC}$	Positive supply voltage

## FUNCTION TABLE

INPUTS				OUTPUTS	STATUS
$\overline{OE}_{xx}$	$\overline{E}_{xx}$	$CP_{xx}$	Data		
H	X	X	X	Z	Outputs disabled
X	H	X	X	Z	Outputs and clock disabled
L	L	↑	l h	H L	Load register
X	↑	L	l h	Z	Load register and disable outputs

- H = High voltage level  
 h = High state present one setup time before the Low-to-High transition  
 L = Low voltage level  
 l = Low state present one setup time before the Low-to-High transition  
 ↑ = Low-to-High transition  
 X = Don't care  
 Z = High-impedance state

Octal Transceiver/Register with  
Dual Enable; 3-State; INV

74AC/ACT11471

## RECOMMENDED OPERATING CONDITIONS

SYMBOL	PARAMETER	74AC11471			74ACT11471			UNIT
		Min	Nom	Max	Min	Nom	Max	
$V_{CC}$	DC supply voltage	3.0 <sup>1</sup>	5.0	5.5	4.5	5.0	5.5	V
$V_I$	Input voltage	0		$V_{CC}$	0		$V_{CC}$	V
$V_O$	Output voltage	0		$V_{CC}$	0		$V_{CC}$	V
$\Delta t/\Delta v$	Input transition rise or fall rate	0		10	0		10	ns/V
$T_A$	Operating free-air temperature	-40		+85	-40		+85	°C

## NOTE:

1. No electrical or switching characteristics are specified at  $V_{CC} < 3V$ . Operation between 2V and 3V is not recommended, but within that range, a device output will maintain a previously established logic state.

ABSOLUTE MAXIMUM RATINGS<sup>1</sup>

SYMBOL	PARAMETER	TEST CONDITIONS	RATING	UNIT
$V_{CC}$	DC supply voltage		-0.5 to +7.0	V
$I_{IK}$ or $V_I$	DC input diode current <sup>2</sup>	$V_I < 0$	-20	mA
		$V_I > V_{CC}$	20	
	DC input voltage		-0.5 to $V_{CC} + 0.5$	V
$I_{OK}$ or $V_O$	DC output diode current <sup>2</sup>	$V_O < 0$	-50	mA
		$V_O > V_{CC}$	50	
	DC output voltage		-0.5 to $V_{CC} + 0.5$	V
$I_O$	DC output source or sink current per output pin	$V_O = 0$ to $V_{CC}$	±50	mA
$I_{CC}$ or $I_{GND}$	DC $V_{CC}$ current		±200	mA
	DC ground current		±200	
$T_{STG}$	Storage temperature		-65 to 150	°C
$P_{TOT}$	Power dissipation per package Plastic DIP	Above 70°C: derate linearly by 8mW/K	500	mW
	Power dissipation per package Plastic surface mount (SO)	Above 70°C: derate linearly by 6mW/K	400	mW

## NOTES:

1. Stresses beyond those listed may cause permanent damage to the device. These are stress ratings only and functional operation of the device at these or any other conditions beyond those indicated under "recommended operating conditions" is not implied. Exposure to absolute-maximum-rated conditions for extended periods may affect device reliability.
2. The input and output voltage ratings may be exceeded if the input and output current ratings are observed.

Octal Transceiver/Register with  
Dual Enable; 3-State; INV

74AC/ACT11471

DC ELECTRICAL CHARACTERISTICS

SYMBOL	PARAMETER	TEST CONDITIONS	V <sub>CC</sub>	74AC11471				74ACT11471				UNIT			
				T <sub>A</sub> = +25°C		T <sub>A</sub> = -40°C to +85°C		T <sub>A</sub> = +25°C		T <sub>A</sub> = -40°C to +85°C					
				Min	Max	Min	Max	Min	Max	Min	Max				
V <sub>IH</sub>	High-level input voltage		3.0	2.10		2.10						V			
			4.5	3.15		3.15		2.0		2.0					
			5.5	3.85		3.85		2.0		2.0					
V <sub>IL</sub>	Low-level input voltage		3.0		0.90		0.90					V			
			4.5		1.35		1.35		0.8		0.8				
			5.5		1.65		1.65		0.8		0.8				
V <sub>OH</sub>	High-level output voltage	V <sub>I</sub> = V <sub>IL</sub> or V <sub>IH</sub>			I <sub>OH</sub> = -50μA	3.0	2.9		2.9				V		
						4.5	4.4		4.4		4.4			4.4	
						5.5	5.4		5.4		5.4			5.4	
						I <sub>OH</sub> = -4mA	3.0	2.58		2.48					
							4.5	3.94		3.8		3.94			3.8
							5.5	4.94		4.8		4.94			4.8
							I <sub>OH</sub> = -24mA	3.0							
4.5															
V <sub>OL</sub>	Low-level output voltage	V <sub>I</sub> = V <sub>IL</sub> or V <sub>IH</sub>			I <sub>OL</sub> = 50μA	3.0			0.1				V		
						4.5			0.1		0.1			0.1	
						5.5			0.1		0.1			0.1	
						I <sub>OL</sub> = 12mA	3.0			0.36		0.44			
							4.5			0.36		0.44			0.36
I <sub>OL</sub> = 24mA	3.0														
	4.5														
	5.5														
	I <sub>OL</sub> = 75mA <sup>1</sup>	3.0													
4.5															
I <sub>I</sub>	Input leakage current	V <sub>I</sub> = V <sub>CC</sub> or GND				5.5			±0.1		±1.0		μA		
I <sub>OZ</sub>	3-State output off-state current	V <sub>I</sub> = V <sub>I</sub> or V <sub>IH</sub> , V <sub>O</sub> = V <sub>CC</sub> or GND				5.5			±0.5		±5.0		μA		
I <sub>CC</sub>	Quiescent supply current	V <sub>I</sub> = V <sub>CC</sub> or GND, I <sub>O</sub> = 0				5.5			8.0		80		μA		
ΔI <sub>CC</sub>	Supply current, TTL inputs High <sup>2</sup>	One input at 3.4V, other inputs at V <sub>CC</sub> or GND				5.5					0.9		mA		

NOTES:

- Not more than one output should be tested at a time, and the duration of the test should not exceed 10ms.
- This is the increase in supply current for each input that is at one of the specified TTL voltage levels rather than 0V or V<sub>CC</sub>.