

32-Bit Bus Switch with GTL Termination for Slotted CPU Applications

Features

- R_{ON} is 1000 Ω typical connected to 1.5V VBIAS
- Low Power.....50 μ W
- Switching Speed.....7.5ns max.
- Channel On Capacitance: 8pF
- V_{CC} Operating Range: +5V \pm 5%
- ESD > 2000V.....Human Body Model
- Packages available: 56-pin TSSOP

\overline{ENX}	Switch
L	On
H	Off

Notes:

When Enabled:

Ports Ax connect to VBIAS..A
Ports Ay connect to VBIAS..B

Where:

X = 0-3, 8-11, 16-19, 24-27
Y = 4-7, 12-15, 20-23, 28-31

Logic Block Diagram

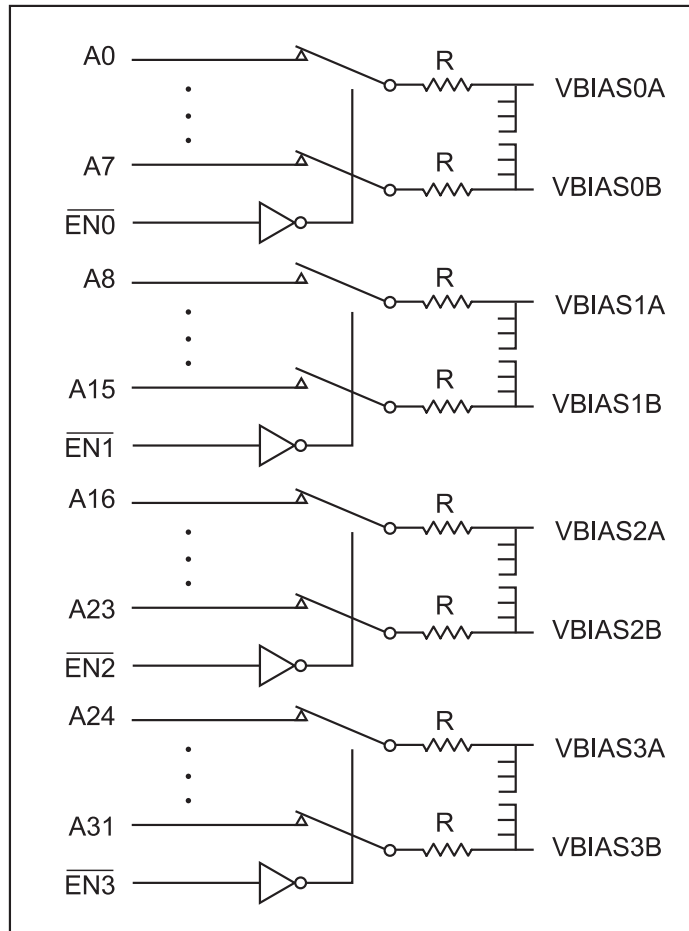

Product Description

Pericom's PI5C32202 is a 32-bit bus switch. Industry leading advantages include very low power, and low I/O capacitance. When the bus switch is enabled ($\overline{ENx} = 0$), it is terminated internally through a series resistor to an external VBIAS. The ON-resistance of the switch along with the series resistor provides a 100 Ω nominal termination to VBIAS.

Applications

Provides GTL termination for busses for three to four processor Pentium II system with an empty Slot II.

Product Pin Configuration

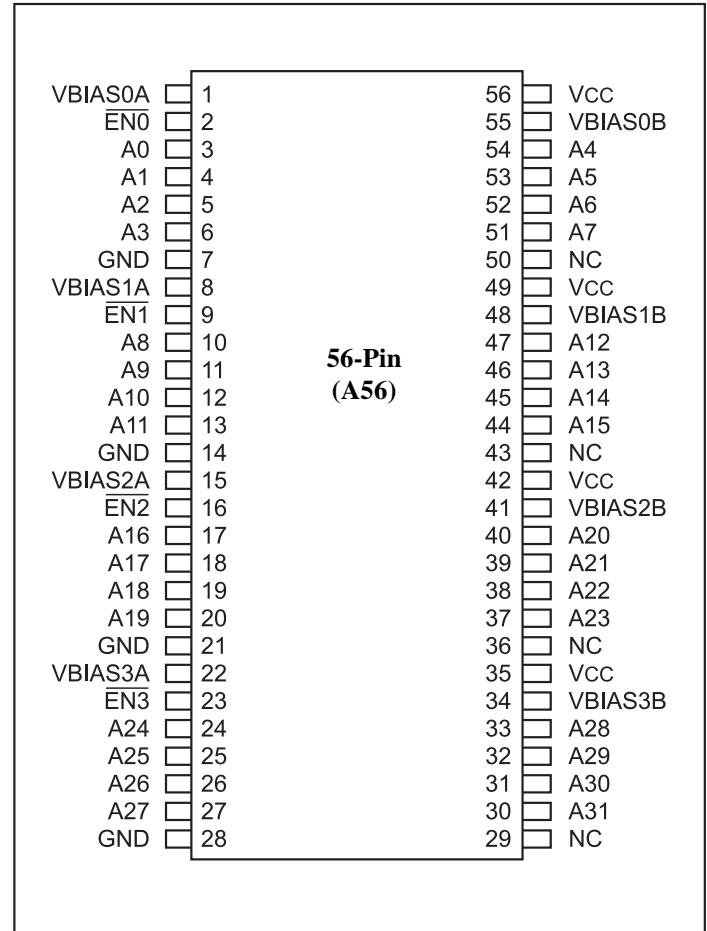



Maximum Ratings

(Above which the useful life may be impaired. For user guidelines, not tested).

Storage Temperature	-65°C to +150°C
Ambient Temperature with Power Applied	-40°C to +85°C
Supply Voltage to Ground Potentials (Inputs & V _{CC} Only)	-0.5V to +7.0V
DC Input Voltage	-0.5V to +7.0V

Note:

Stresses greater than those listed under MAXIMUM RATINGS may cause permanent damage to the device. This is a stress rating only and functional operation of the device at these or any conditions above those indicated in the operational sections of this specification is not implied. Exposure to absolute maximum rating conditions for extended periods of time may affect reliability.

DC Electrical Characteristics (V_{CC} = 5V ± 5%, T_A = 0°C to +85°C)

Parameter	Description	Test Conditions	Min.	Typ.	Max.	Units
V _{IH}	TTL Input HIGH Voltage	Enable	2.0	—	—	V
V _{IL}	TTL Input LOW Voltage		0.5	—	0.8	
I _{IH}	TTL Input HIGH Current		—	—	1	μA
I _{IL}	TTL Input LOW Current		—	—	1	
R _{ON}	Switch On Resistance	V _{CC} = Min., V _{IN} = 0.0V, VBIAS = 1.5V	80	100	120	Ω
C _{IN}	Input Capacitance	V _{IN} = 0V	—	4	—	pF
C _{ON}	Input Capacitance, Switch On		—	8	—	
I _{CC}	Power Supply Quiescent		—	—	10	μA

AC Electrical Characteristics (V_{CC} = 5V ± 5%, T_A = 0°C to +85°C)

Parameter	Description	Test Conditions	Min.	Max.	Units
t _{PE}	Bus Enable	C _L = 20pF, R _L = 500Ω	1	5	ns
t _{PD}	Bus Disable				

Ordering Information

Part	Pin-Package	Width
PI5C32202	56-TSSOP (A56)	240-mil