

NATIONAL HYBRID INC. RONKONKOMA, N.Y. 11779

Miniature, Hermetically Sealed Optocoupler NHI 6037

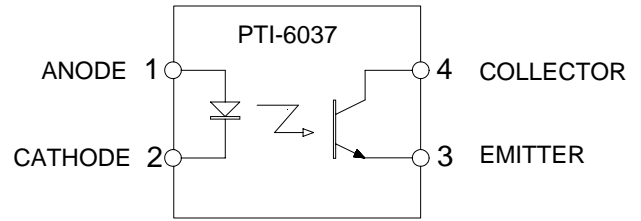

Features;

- -55°C to +125°C Operation
- Output Voltage to 30V
- Input Current from < 2mA
- Low Output Saturation Typ < 0.3V
- Withstanding Voltage > 1500Vdc
- Functionally Compatible with 4N37

Terminal Number	Terminal Function
1	ANODE
2	CATHODE
3	EMITTER
4	COLLECTOR

Absolute Maximum Ratings;

Supply Voltage (Vcc)	-0.5 to 30Vdc
Continuous Input Current	60mA
Peak Input Current If (10uS,300Hz)	3A
Reverse Input Voltage Vr	5 Vdc
Led Power Dissipation (At Tc=25°C).....	100mW
Output Current	100mA
Output Voltage	-0.5 to 30Vdc
Output Power Dissipation	300mW
Storage Temperature	-65°C to 150°C
Lead Solder Temperature	260°C for 10 sec.
Junction Temperature	175°C

Recommended Operating Conditions;

Output Voltage Range	to 30Vdc
Input Current	0.5 mA to 15mA
Ambient Operating Temperature Range	-55°C to 125°C

Electrical Performance Characteristics;

(At $T_a = 25^\circ\text{C}$ unless otherwise specified)

TEST	SYM-BOL	CONDITIONS	LIMITS		UNITS
			MIN	MAX	
Current Transfer Ratio	Ctr	$V_{ce} = 10\text{V}$, $I_f = 10\text{mA}$ (at $T_a = 25^\circ\text{C}$) _1	100		%
		$V_{ce} = 10\text{V}$, $I_f = 10\text{mA}$ (at $T_a = -55^\circ\text{C}$) _1	50		
		$V_{ce} = 10\text{V}$, $I_f = 10\text{mA}$ (at $T_a = 125^\circ\text{C}$) _1	50		
Collector - Emitter breakdown Voltage	V_{ceo}	$I_c = 100\mu\text{A}$	30	60	Vdc
Emitter - Collector Breakdown Voltage	V_{eco}	$I_e = 10\mu\text{A}$	5.0	7.5	Vdc
Output Saturation Voltage	$V_{ce}(\text{sat})$	$I_f = 10\text{mA}$, $I_c = 1.0\text{mA}$	0.3		Vdc
High Level Output Current (dark current)	I_{ceo}	$V_{cc} = 30\text{V}$, $I_f = 0\mu\text{A}$ (at $T_a = 125^\circ\text{C}$)		500	μA_{dc}
Input Forward Voltage	V_f	$I_f = 10\text{mA}$		1.7	Vdc
Input Reverse Breakdown Voltage	V_{br}	$I_r = 10\mu\text{A}$	5.0	30	Vdc

Switching Characteristics:

(at $T_a = 25^\circ\text{C}$) unless otherwise specified)

Non-saturated Turn on time	T_{on}	$I_c = 2\text{mA}$, $R_I = 100\text{ohm}$, $V_{cc} = 5\text{V}$		7.0	μS
Non-saturated Turn off time	T_{off}	$I_c = 2\text{mA}$, $R_I = 100\text{ohm}$, $V_{cc} = 5\text{V}$		7.0	μS
Saturated Turn-on time	T_{on}	$I_f = 16\text{mA}$, $R_I = 2.0\text{K}$, $V_{cc} = 5\text{V}$		5.0	μS
Saturated Turn-off time	T_{off}	$I_f = 16\text{mA}$, $R_I = 2.0\text{K}$, $V_{cc} = 5\text{V}$		40.0	μS

Isolation Characteristics:

(at Ta = 25°C unless otherwise specified)

TEST	SYM-BOL	CONDITIONS	LIMITS		UNITS
			MIN	MAX	
Capacitance, input to output	Cio	f = 1Mhz, Ta = 25°C _3_4		4	pF
Common Mode Transient Immunity, high output	Cmh	Vcm = 25v (peak) Vcc = 5.0v, RI = 2.0K If = 0mA, _4_5_6	500		V/μs
Common Mode Transient Immunity, lo output	Cml	Vcm = 25v (peak) Vcc = 5.0v, RI = 2.0K If = 0mA, _4_5_6	500		V/μs
Input to Output Insulation Leakage Current	lio	Vio = 1500Vdc, Relative Humidity = 5%, T = 5 Seconds, Ta = 25°C _2_4	1.0		μAdc

Notes;

- _1 Ctr is defined as the ratio of the Output Collector current (Io) to the LED Forward Current (If), times 100%.
- _2 Device is considered a two terminal device. Pins 1 and 2 are shorted together and pins 4, and 5 are shorted together.
- _3 Measured between the LED cathode and pins 4 and 5 (shorted together).
- _4 Parameters shall be tested as part of the device's initial characterization . Parameters are guaranteed to the limits specified for all lots not specifically tested.
- _5 Cmh is the maximum common mode transient to assure that the output will remain in a high logic state (Vo > 2.0V).
- _6 In applications where dV/dt may exceed 50,000 V/μs a series resistor must be included in the Vcc line to limit destructively high surge currents. The recommended value, at If = 0.5mA, is 3.3K
- _7 Cml is the maximum common mode transient to assure that the output will remain in a low logic state (Vo < 0.8V).

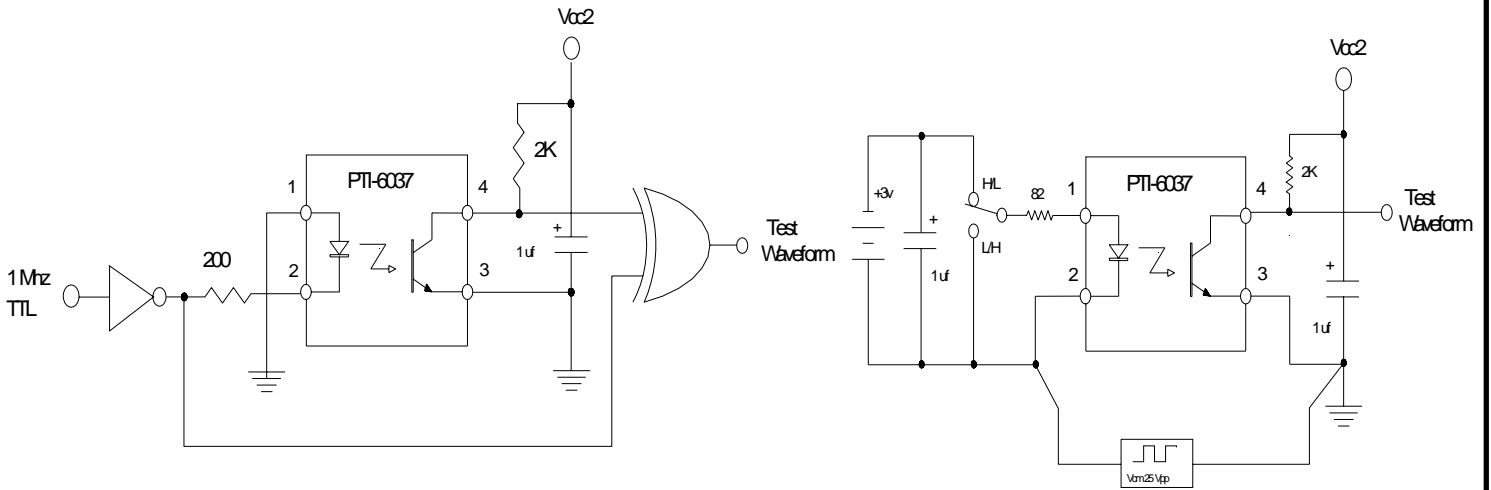

Fig 1 Switching Time Test Circuit

Fig 2 Common Mode Test circuit

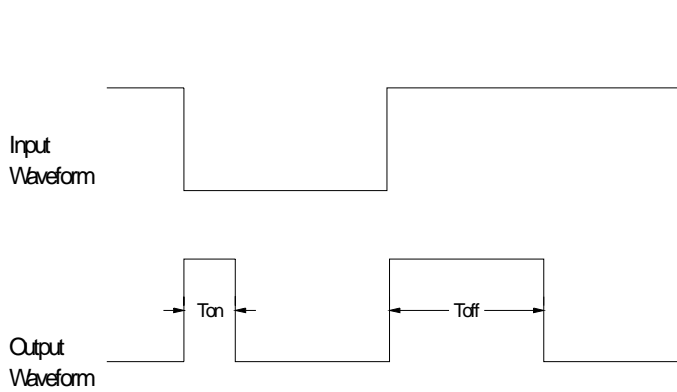

Fig 3 Switching Time Test Waveform

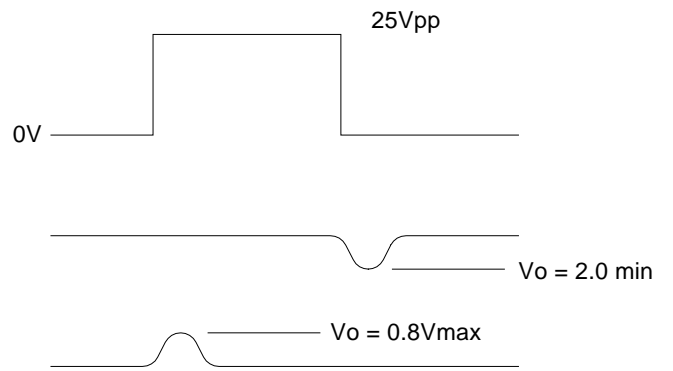
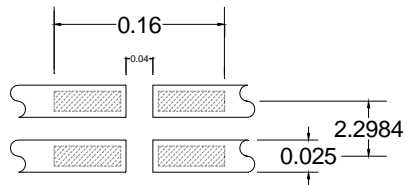
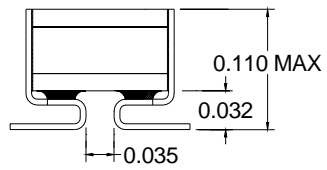
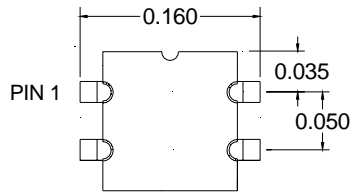

Fig 4 Common Mode Test Waveform

GULLWING

OPTION (-X)



TYPICAL P.C. PATTERN

LEADLESS

OPTION (-Z)

