



PTC thermistors for telecom

SMDs

Series/Type: B59***
Date: March 2007



Applications

- Overcurrent protection for telecom applications
- Suitable for line card applications e.g. POTS, access networks, customer premises equipment (CPE) or intergated voice data (IVD)

Features

- Compliant with ITU-T standards
 - basic level lightning surges (10/700 μ s)
 - basic level power induction (600 V, 1 A, 0.2 s)
 - power contact criteria A/B (230 V, 15 min.)
- Suitable for continuous connection to mains voltages of 110/230 VAC in tripped (high ohmic) condition
- UL approval for gamma I version to UL 1434 (file number E69802)
- Matching available with narrow resistance tolerance
- Marked with type designation and date code
- RoHS-compatible

Options

- Alternative tolerances and resistances on request

Delivery mode

- Type G10**: blister tape, 330-mm reel with 16-mm (Gamma I) or 24-mm tape (Gamma L), taping to IEC 60286-3
- Type R212: bulk

General technical data

Max. operating voltage		V_{\max}	245	VAC
Operating temperature range	(V = 0)	T_{op}	-20/+125	°C
Operating temperature range	(V = 230 V)	T_{op}	0/+70	°C

Electrical specifications and ordering codes

Type	R_R Ω	ΔR_R %	$R_{25,match}$ Ω	I_R @ 25 °C mA	I_R @ 70 °C mA	I_S @ 25 °C mA	I_{Smax} @ 230 VAC A	Ordering code
Gamma I								
G1081	9	±20	0.5	180	120	400	1.0	B59081G1120A161
G1085	10	±20	1.0	180	120	400	1.0	B59085G1120A161
G1083	16	±20	0.5	150	100	300	1.5	B59083G1120A161
G1080	25	±20	1.0	130	85	270	2.8	B59080G1120B262
G1086	29	±20	1.0	125	80	260	2.8	B59086G1120B262
G1084	50	±15	1.0	90	60	190	2.5	B59084G1120A161
Gamma L								
G1040	25	±20	1.0	120	80	250	4.0	B59040G1120B161
G1012	35	+15/-20	1.0	100	65	250	4.6	B59012G1120A161
Square disk								
R212	12	±15	no	120	50	300	1.5	B59212R0080B140

Switching times and ordering codes

Type	t_S (typ) @ I_{Smax} , 230 VAC s	t_S (typ) @ 1 A, 230 VAC s	t_S (typ) @ 500 mA, 230 VAC s	Ordering code
Gamma I				
G1080	0.2	1.5	6.5	B59080G1120B262
G1081	4.4	4.4	23.0	B59081G1120A161
G1083	1.0	2.4	11.0	B59083G1120A161
G1084	0.13	0.8	3.1	B59084G1120A161
G1085	3.9	3.9	19.0	B59085G1120A161
G1086	0.18	1.3	5.5	B59086G1120B262
Gamma L				
G1012	0.05	0.8	3.5	B59012G1120A161
G1040	0.08	1.1	5.0	B59040G1120B161
Square disk				
R212	0.7	--	--	B59212R0080B140

Dimensional drawings for Gamma I

Dimensions in mm

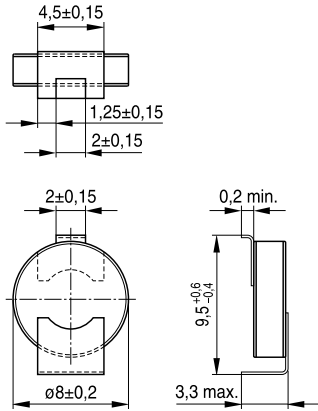

TPT0656-U

Solder pad

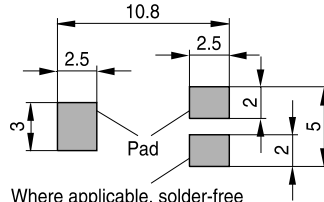

Where applicable, solder-free area (for glue application)

TPT0776-F-E

Dimensional drawings for Gamma L

Dimensions in mm

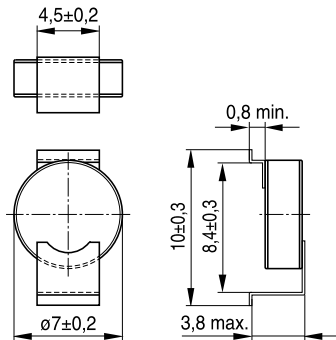

TPT0775-7

Solder pad

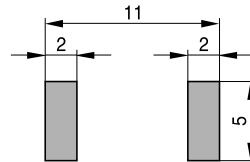

TPT0777-N

SMD

Dimensional drawings for square disk

Dimensions in mm

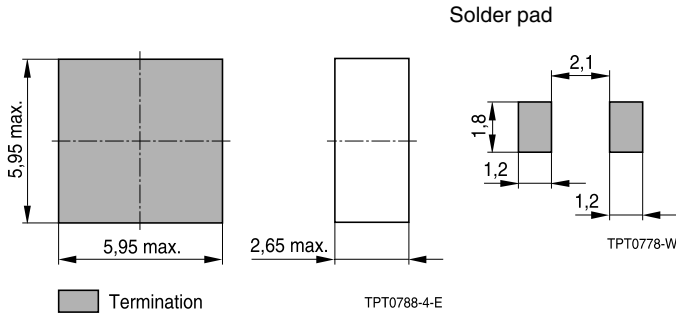

Packaging

Type	Packaging
Gamma I	
G1080	16-mm tape
G1081	16-mm tape
G1083	16-mm tape
G1084	16-mm tape
G1085	16-mm tape
G1086	16-mm tape
Gamma L	
G1012	24-mm tape
G1040	24-mm tape
Square disk	
R212	Bulk



Cautions and warnings

General

- EPCOS thermistors are designed for specific applications and should not be used for purposes not identified in our specifications, application notes and data books unless otherwise agreed with EPCOS during the design-in-phase.
- Ensure suitability of thermistor through reliability testing during the design-in phase. The thermistors should be evaluated taking into consideration worst-case conditions.

Storage

- Store thermistors only in original packaging. Do not open the package before storage.
- Storage conditions in original packaging: storage temperature $-25\text{ }^{\circ}\text{C} \dots +45\text{ }^{\circ}\text{C}$, relative humidity $\leq 75\%$ annual mean, maximum 95%, dew precipitation is inadmissible.
- Avoid contamination of thermistors surface during storage, handling and processing.
- Avoid storage of thermistor in harmful environment with effect on function on long-term operation (examples given under operation precautions).
- Use thermistor within 6 months after delivery.

Handling

- PTCs must not be dropped. Chip-offs must not be caused during handling of PTCs.
- Components must not be touched with bare hands. Gloves are recommended.
- Avoid contamination of thermistor surface during handling.

Soldering (where applicable)

- Use rosin-type flux or non-activated flux.
- Insufficient preheating may cause ceramic cracks.
- Rapid cooling by dipping in solvent is not recommended.
- Complete removal of flux is recommended.
- Standard PTC heaters are not suitable for soldering.

Mounting

- Electrode must not be scratched before/during/after the mounting process.
- Contacts and housing used for assembly with thermistor have to be clean before mounting. Especially grease or oil must be removed.
- When PTC thermistors are encapsulated with sealing material, the precautions given in chapter "Mounting instructions", "Sealing and potting" must be observed.
- When the thermistor is mounted, there must not be any foreign body between the electrode of the thermistor and the clamping contact.
- The minimum force of the clamping contacts pressing against the PTC must be 10 N.
- During operation, the thermistor's surface temperature can be very high. Ensure that adjacent components are placed at a sufficient distance from the thermistor to allow for proper cooling at the thermistors.
- Ensure that adjacent materials are designed for operation at temperatures comparable to the surface temperature of thermistor. Be sure that surrounding parts and materials can withstand this temperature.
- Avoid contamination of thermistor surface during processing.

SMD

Operation

- Use thermistors only within the specified temperature operating range.
- Use thermistors only within the specified voltage and current ranges.
- Environmental conditions must not harm the thermistors. Use thermistors only in normal atmospheric conditions. Avoid use in deoxidizing gases (chlorine gas, hydrogen sulfide gas, ammonia gas, sulfuric acid gas etc), corrosive agents, humid or salty conditions. Contact with any liquids and solvents should be prevented.
- Be sure to provide an appropriate fail-safe function to prevent secondary product damage caused by abnormal function (e.g. use VDR for limitation of overvoltage condition).

Important notes

The following applies to all products named in this publication:

1. Some parts of this publication contain **statements about the suitability of our products for certain areas of application**. These statements are based on our knowledge of typical requirements that are often placed on our products in the areas of application concerned. We nevertheless expressly point out **that such statements cannot be regarded as binding statements about the suitability of our products for a particular customer application**. As a rule, EPCOS is either unfamiliar with individual customer applications or less familiar with them than the customers themselves. For these reasons, it is always ultimately incumbent on the customer to check and decide whether an EPCOS product with the properties described in the product specification is suitable for use in a particular customer application.
2. We also point out that **in individual cases, a malfunction of passive electronic components or failure before the end of their usual service life cannot be completely ruled out in the current state of the art, even if they are operated as specified**. In customer applications requiring a very high level of operational safety and especially in customer applications in which the malfunction or failure of a passive electronic component could endanger human life or health (e.g. in accident prevention or life-saving systems), it must therefore be ensured by means of suitable design of the customer application or other action taken by the customer (e.g. installation of protective circuitry or redundancy) that no injury or damage is sustained by third parties in the event of malfunction or failure of a passive electronic component.
3. **The warnings, cautions and product-specific notes must be observed**.
4. In order to satisfy certain technical requirements, **some of the products described in this publication may contain substances subject to restrictions in certain jurisdictions (e.g. because they are classed as “hazardous”)**. Useful information on this will be found in our Material Data Sheets on the Internet (www.epcos.com/material). Should you have any more detailed questions, please contact our sales offices.
5. We constantly strive to improve our products. Consequently, **the products described in this publication may change from time to time**. The same is true of the corresponding product specifications. Please check therefore to what extent product descriptions and specifications contained in this publication are still applicable before or when you place an order. We also **reserve the right to discontinue production and delivery of products**. Consequently, we cannot guarantee that all products named in this publication will always be available.
6. Unless otherwise agreed in individual contracts, **all orders are subject to the current version of the “General Terms of Delivery for Products and Services in the Electrical Industry” published by the German Electrical and Electronics Industry Association (ZVEI)**.
7. The trade names EPCOS, EPCOS-JONES, BAOKE, Alu-X, CeraDiode, CSSP, MLSC, MotorCap, PhaseCap, PhaseMod, SIFERRIT, SIFI, SIKOREL, SilverCap, SIMID, SIOV, SIP5D, SIP5K, WindCap are **trademarks registered or pending** in Europe and in other countries. Further information will be found on the Internet at www.epcos.com/trademarks.