

# VSC7384



## Stansted™ – 12-port Gigabit Ethernet Switch-on-a-Chip



### 12-PORT TRI-SPEED DESKTOP SWITCH:

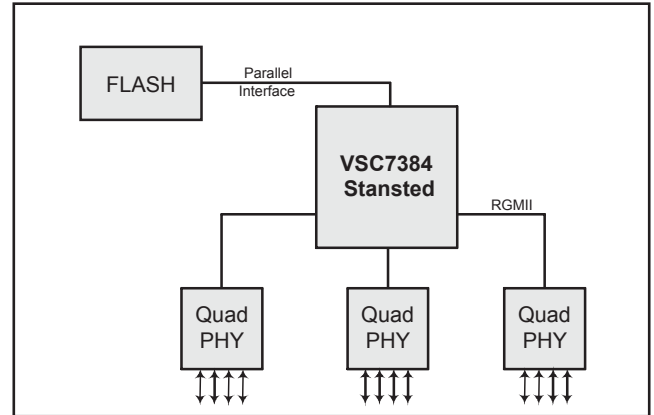

#### FEATURES:

- ▶ 12 Gigabit Ethernet Ports with Non-blocking Wire-speed Performance
- ▶ Tri-speed (10/100/1000 Mbit/s) Operation via RGMII Interfaces
- ▶ 208 KB On-chip Frame Buffer
- ▶ 8/16-bit CPU Interface, and 4-wire Serial CPU Interface
- ▶ On-Chip 8051 CPU
- ▶ Jumbo Frame Support
- ▶ Programmable Classifier for QoS (Layer 2-4), Including **IEEE Std 802.1p™**
- ▶ 8K MAC Addresses and 4K VLANs (**IEEE Std 802.1Q™**)
- ▶ Full Duplex Flow Control (**IEEE Std 802.3x™**) and Half Duplex Back Pressure
- ▶ Multicast and Broadcast Storm Control
- ▶ Flexible Link Aggregation Compliant to **IEEE Std 802.3ad™**
- ▶ Multiple protocol Support **IEEE Std 802.1D™, IEEE Std 802.1W™, IEEE Std 802.1s™, IEEE Std 802.1X™**

#### BENEFITS:

- ▶ Ensures Maximum Data Throughput on Even Highly Loaded Networks
- ▶ Simplifies PCB Layout Significantly by Utilizing Reduced Mode Interface Standards for all Speeds
- ▶ Eliminates the Need for External Buffer Memory While Maintaining High Peak Load Performance
- ▶ Enables Advanced Switch Management Using Run-time Protocols, in Addition to Low Cost Unmanaged and Web Managed Operation
- ▶ Enables Ultra Low-cost Web Managed Switch Systems
- ▶ Connects Effortlessly to Networks, Hosts, and Controllers that Utilize up to 12K Sized Jumbo Frames
- ▶ Optimizes Network Performance to Support any Digital Stream, from Internet Browsing to VoIP and Video
- ▶ Stores a Large Amount of Stations at Wire Speed in the On-chip MAC Table, Ensuring Optimal Network Performance
- ▶ Ensures Loss-less Data Transmission While Supporting Existing Legacy Ethernet Equipment
- ▶ Eliminates Unwanted Flooding of Ports and Thereby Increases Overall Network Performance
- ▶ Provides High Bandwidth Uplinking Abilities
- ▶ Supports Complex Network Topologies with Fast Failure Recovery, and Access Control

#### APPLICATIONS:

- ▶ 12-port Web Managed Tri-speed Desktop Switch
- ▶ 12-port Unmanaged Tri-speed Desktop Switch
- ▶ 12-port Smart Managed Tri-speed Desktop Switch
- ▶ Control Plane Controller

Enterprise

Access

Metro

Core

## Stansted™ – 12-port Gigabit Ethernet Switch-on-a-Chip

### GENERAL DESCRIPTION:



*Stansted™ is a highly integrated, single-chip Ethernet switch with 12 non-blocking ports. As part of Vitesse's London™ Family Of Switches, Stansted delivers high performance with easy migration paths, and comprehensive System Solutions that enable ultra-short time-to-market and market leading system cost.*

### A Vitesse Switch Family Member

Stansted is a part of the Vitesse London™ Family Of Switches. With its 12 tri-speed ports, it is specifically targeted at small-medium business applications. In addition, Stansted enables Web Management at unprecedented low cost by sporting a fully integrated on-chip 8051 micro controller. Additionally, the on-chip 8051 is perfectly suited for unmanaged systems as well.

Being a member of the switch family provides a number of unique advantages when designing with the chip, including nearly 100% software compatibility between members. Thus, software written for Stansted can easily be used with other switch configurations in the family, and vice-versa.

Additionally, building a product family is easy when designing with Vitesse switches. Upgrading designs to other port counts, or migrating to other configurations or future technology is achievable with minimum effort and time.

### The Vitesse London Family Of Switches

Stansted, as part of the Vitesse London Family Of Switches, shares the unique traits of the family.

The highly integrated switches require no external memory at all, and the use of Reduced Mode interfaces (RGMII) simplifies PCB layout to reduce time and cost. Further trimming down system cost is the persistently low power dissipation of the family.

The switches provide for high performance designs with their non-blocking, wire-speed performance, which includes wire-speed MAC address learning.

### SPECIFICATIONS:

- ▶ 25 MHz LVTTTL Reference Clock
- ▶ 1.8 V Core Power Supply
- ▶ 2.5 and 3.3 V Interface Power Supply
- ▶ 448-pin TEPBGA-2 Package

For more information on Vitesse Products visit the Vitesse web site at [www.vitesse.com](http://www.vitesse.com) or contact Vitesse Sales at (800) VITESSE or [sales@vitesse.com](mailto:sales@vitesse.com)

Designing both unmanaged and managed solutions is straightforward. The chips offer both serial and parallel CPU interfaces, and support a host of management protocols such as GxRP, SNMP, and three flavors of Spanning Tree: Standard STP, Multiple STP, and Rapid STP.

Gaining control with networks operated by the Vitesse switches is simple; advanced Layer 2-4 classification, plus shaping and policing functionality, along with port authentication support, provide flexible QoS operation. This is backed up by link aggregation and VLAN support, enabling advanced techniques such as "802.1Q-in-802.1Q" to be deployed. Additionally, OAM is supported for designing switch products for Ethernet in the MAN.

Designing with Vitesse London Family Of Switches means designing with the whole Vitesse Solution:

The outstanding Vitesse web managed switch software system that runs on a standard 8051 controller, is provided. This is in addition to the unmanaged and smart managed software systems for 8051, which are also included. For homegrown software development our full platform and OS independent switch API is supplied.

Accompanying the software systems are the Vitesse Switch Reference Systems. These are production-ready hardware designs that also serve as evaluation platforms for our switches.

The Vitesse Solution is supplied with a comprehensive collateral package, which includes software source code, full documentation, and an in-depth qualification report for easy pre-evaluation.

### BLOCK DIAGRAM:

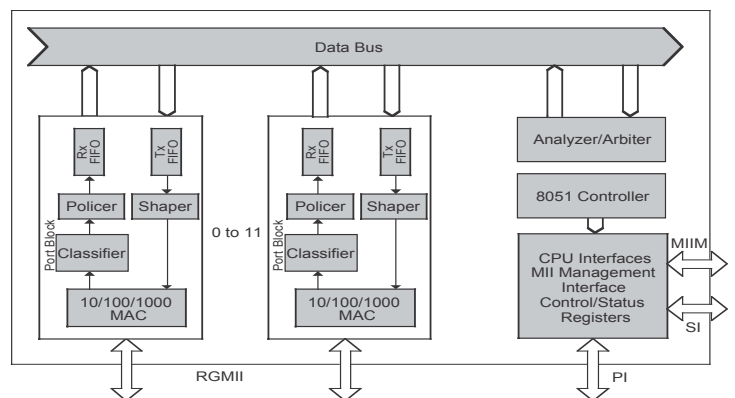

# VITESSE

741 Calle Plano  
Camarillo, CA 93012, USA  
Tel: +1 805.388.3700  
Fax: +1 805.987.5896  
[www.vitesse.com](http://www.vitesse.com)