

One-Chip AM/FM Receiver IC for Digital Tuning

Description

The U2514B is an integrated bipolar radio circuit suitable for digital tuning systems. It contains an FM front end with pre-amplifier and FM-stereo decoder as well as a complete AM receiver and demodulator. Stop-signal

generation is implemented for FM and AM mode. This circuit is designed for use in small radios, power packs and multimedia applications

Features

- FM wideband AGC
- LO-buffer for digital tuning
- Integrated stop-signal generation for AM and FM
- Adjustable stop-signal sensitivity
- Automatic stereo-mono blend
- High cut
- Mute function
- Pilot canceller
- Supply voltage range 3 to 12 V

Block Diagram

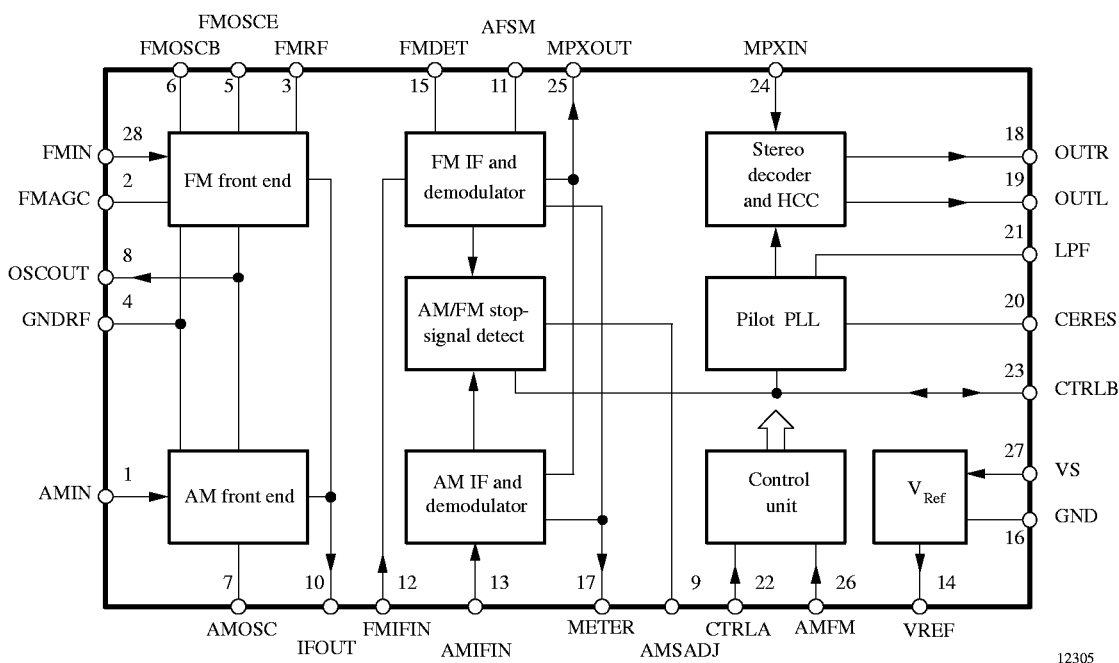

Figure 1. Block diagram

Ordering Information

Extended Type Number	Package	Remarks
U2514B-M	DIP28	Tube
U2514B-MFN	SSO28	Tube
U2514B-MFNG3	SSO28	Taped and reeled according to ICE-286-3

Pin Description

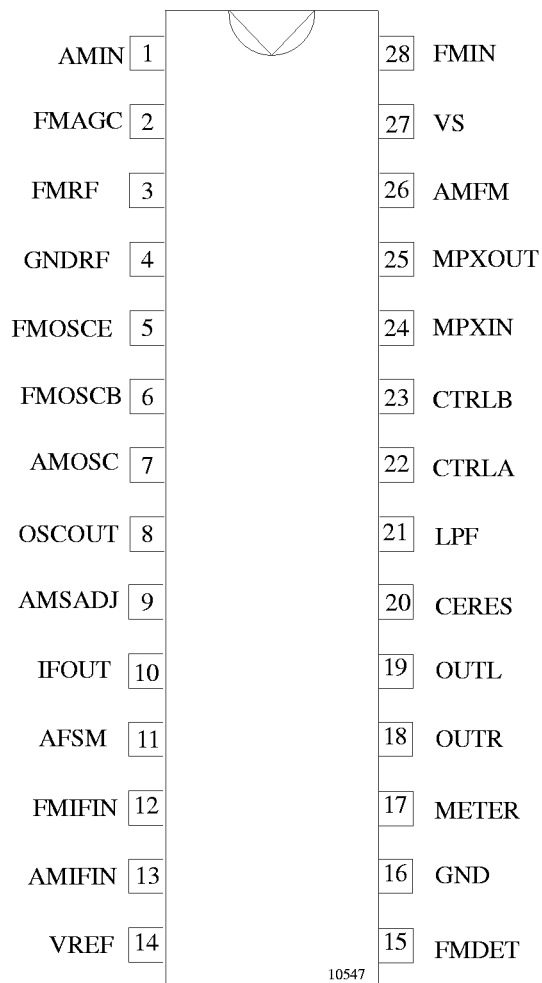

Figure 2. Pinning

Pin	Symbol	Function
1	AMIN	AM antenna input
2	FMAGC	FM AGC time constant
3	FMRF	FM RF tank
4	GNDRF	Ground RF
5	FMOSCE	FM oscillator emitter
6	FMOSCB	FM oscillator basis
7	AMOSC	AM oscillator
8	OSCOUT	Buffered AM/FM oscillator output
9	AMSADJ	Current input for AM stop-signal adjustment
10	IFOUT	AM/FM IF output
11	AFSM	AF smoothing voltage
12	FMIFIN	FM IF amplifier input
13	AMIFIN	AM IF amplifier input
14	VREF	Reference voltage
15	FMDET	FM discriminator output
16	GND	Ground
17	METER	Field-strength output
18	OUTR	AF output right
19	OUTL	AF output left
20	CERES	Resonator 456 kHz
21	LPF	Lowpass filter for pilot-PLL
22	CTRLA	Control input for mute, search mode and search sensitivity
23	CTRLB	Control input for forced mono, control output for stop function and stereo information
24	MPXIN	Stereo decoder MPX input
25	MPXOUT	AM/FM MPX output
26	AMFM	AM/FM switch and pilot canceller time constant
27	VS	Supply voltage
28	FMIN	FM antenna input

Pin Description with Typical DC Values

Pin	Symbol	Function	AM	FM
1	AMIN	AM antenna input	V_{Ref}	High impedance
2	FMAGC	FM AGC time constant	V_{Ref}	$V_{Ref} - 80 \text{ mV}$
3	FMRF	FM RF tank	High impedance	$V_S / 0$ to 1 mA
4	GNDRF	Ground RF	GND	GND
5	FMOSCE	FM oscillator emitter	$V_{Ref} - 2 V_{BE} / 0 \text{ A}$	0.95 V
6	FMOSCB	FM oscillator basis	$V_{Ref} - V_{BE} / 0 \text{ A}$	1.7 V
7	AMOSC	AM oscillator	$V_{Ref} / \text{in } 0.3 \text{ mA}$	High impedance
8	OSCOU	Buffered AM/FM oscillator output	$V_{Ref} / \text{in } 0.3 \text{ mA}$	$V_{Ref} / \text{in } 0.7 \text{ mA}$
9	AMSADJ	Current input for AM stop-signal adjustment	AMsearch = V_{BE} AM = 0.1 V	0.1 V
10	IFOUT	AM/FM IF output	$V_S / \text{in } 50 \text{ A}$	$V_S / \text{in } 0.4 \text{ mA}$
11	AFSM	AF smoothing	0.8 to 1.2 V	1.2 V
12	FMIFIN	FM IF amplifier input	V_{BE} to GND / 0 A	V_{BE} to GND
13	AMIFIN	AM IF amplifier input	3.3 k to V_{Ref}	3.3 k to V_{Ref}
14	VREF	Reference voltage output	$V_{Ref} = 2.4 \text{ V}$	$V_{Ref} = 2.4 \text{ V}$
15	FMDDET	FM discriminator	$V_{Ref} / 1 \text{ A}$	$V_{Ref} / 0 \text{ A}$
16	GND	Ground	GND	GND
17	METER	Field-strength output	0 to 2.3 V	0 to 2 V
18	OUTR	AF output right	0 to 2.3 V / 0.15 mA	0 to 2.3 V / 0.15 mA
19	OUTL	AF output left	0 to 2.3 V / 0.15 mA	0 to 2.3 V / 0.15 mA
20	CERES	Ceramic resonator 456 kHz for AM search and for pilot-PLL in FM mode	0.1 to 2.3 V	0.1 to 2.3 V
21	LPF	Lowpass filter for pilot-PLL AM	0.2 V	
		Lowpass filter for pilot-PLL AM search and FM	0.5 to 2 V	0.5 to 2 V
22	CTRLA	Control input for mute, search mode and search sensitivity	0 to V_{Ref}	0 to V_{Ref}
23	CTRLB	Control input for forced mono , Control output for stop function, mono / stereo information	0.1 V to V_S 30 k	0.1 V to V_S 30 k
24	MPXIN	Stereo decoder MPX input	0.8 V	0.8 V
25	MPXOUT	AM/FM MPX output	0.8 to 1.2 V	1.2 V
26	AMFM	AM/FM switch and pilot canceller time constant	GND	1.54 V
27	VS	Supply-voltage input	3 to 12 V / in 5 mA	3 to 12 V / in 9 mA
28	FMIN	FM antenna input	$V_{Ref} - V_{BE} / 0 \text{ A}$	1.5 V

Pin Description

FMIN, FMAGC, FMRF

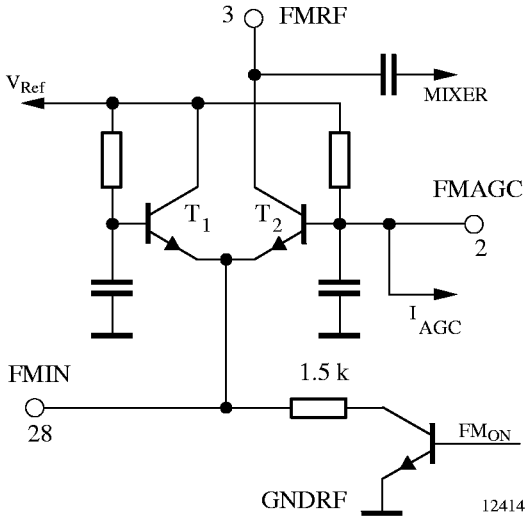

Figure 3.

The FM preamplifier input FMIN (Pin 28) consists of a transistor-grounded base circuit (T_2) which provides excellent noise performance and large signal behavior. It is recommended to connect a source impedance of 100 in order to achieve optimal performance. The dc current through the amplifying transistor is reduced by the internal AGC. This means in the case of large input signals, the input ac current is bypassed via the wideband AGC transistor (T_1). A capacitor is connected between FMAGC (Pin 2) and GNDRF (Pin 4). It shortens the transistor base to GNDRF (Pin 4) and smoothes the AGC voltage. A tuned RF circuit is connected between FMRF (Pin 3) and VS (Pin 27). The amplified RF signal is fed internally to the mixer input.

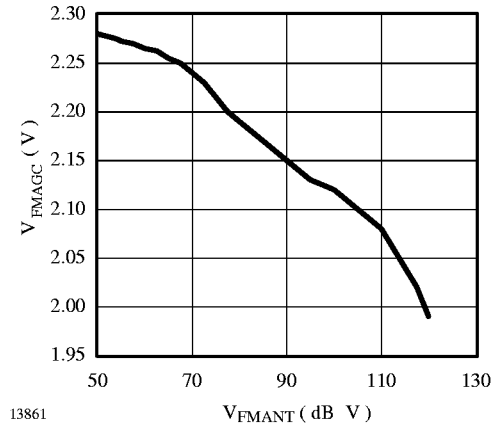

Figure 4. FM AGC characteristic

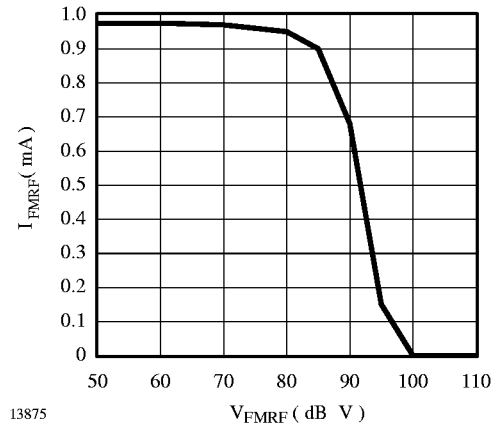

Figure 5. FM AGC characteristic

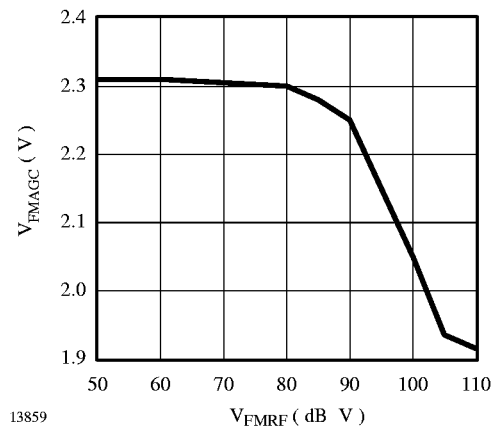

Figure 6. FM AGC characteristic

FMOSCE, FMOSCB

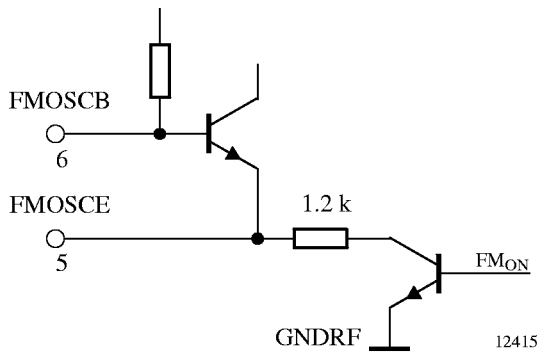

Figure 7.

The FM local oscillator consists of a transistor in grounded-collector configuration. The negative resistance at the base of the transistor is generated by an external capacitor connected between emitter FMOSCE (Pin 5) and GNDRF (Pin 4). Another external capacitor is connected between base FMOSCB (Pin 6) and emitter FMOSCE (Pin 5) which increases the resistance at the emitter and leads to a higher oscillator swing. The negative resistance at FMOSCB (Pin 6) is approximately 250 Ω . Therefore, the resonant LO tank resistance of approximately 5 k Ω (depends on the Q-factor of the coil) is transformed to this magnitude via a capacitor.

OSCOUT

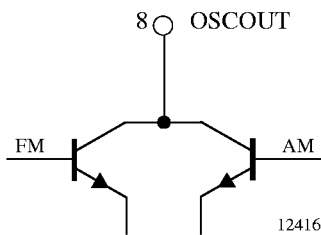

Figure 8.

A resistor is connected between OSCOUT (Pin 8) and VREF (Pin 14). It determines the amplitude of the oscillator voltage which is fed to the PLL circuit. The TEMIC PLL family U428xBM is recommended as members of this family offer high signal-to-noise ratio and low current consumption.

AMIN

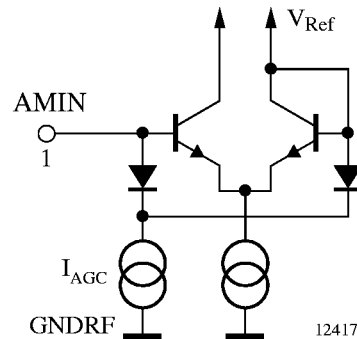

Figure 9.

The AM antenna coil is connected between AMIN (Pin 1) and VREF (Pin 14). In order to ensure that the AGC operates correctly, a coil impedance of approximately 25 k Ω is necessary.

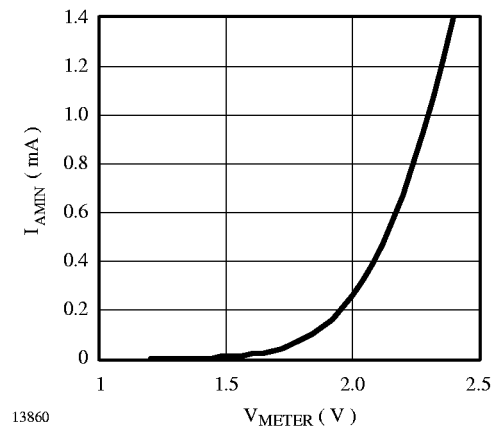

Figure 10. AM AGC characteristic

AMOSC

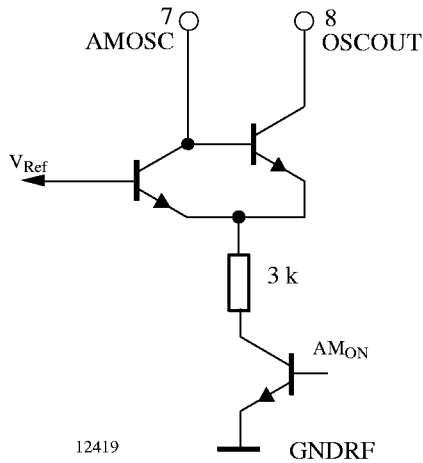

Figure 11.

The AM oscillator has to be loaded by an external tank referred to VREF (Pin 14).

IFOUT

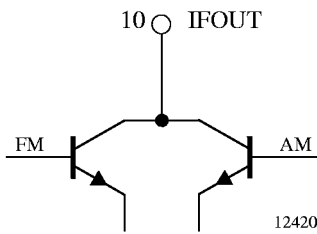

Figure 12.

The IF output (IFOUT, Pin 10) of both the FM and the AM mixer has to be loaded into external IF-tank circuits referred to VREF (Pin 14). The Q-factor of IF coils must not be lower than 50.

AMSADJ

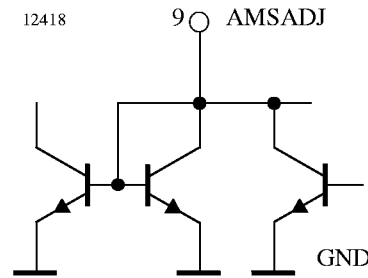

Figure 13.

The ceramic resonator of the stereo decoder PLL circuit is used as a stop-signal detector for AM signals. For this purpose, the parallel resonance frequency of the resonator, which is unloaded about 456 kHz, is reduced by an internal load capacitor to 455 kHz. Therefore, **the AM IF must be 455 kHz**. The internal loading capacitor is defined by the current through AMSADJ (Pin 9) to GND. An external resistor is connected between AMSADJ (Pin 9) and VREF. It permits the alignment of the stop-signal center frequency. The width of the stop window is typically 1.2 kHz. If AM search mode is not activated, the pin is internally pulled to ground.

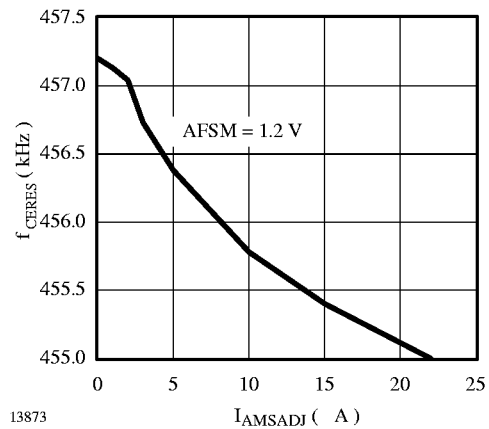

Figure 14. Pulling characteristic

AMIFIN

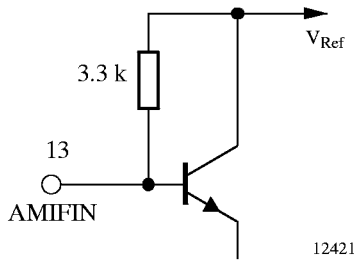

Figure 15.

The input impedance of the AM IF amplifier is 3.3 k according to the required impedance of most ceramic filters. The input refers to VREF (Pin 14).

FMDET

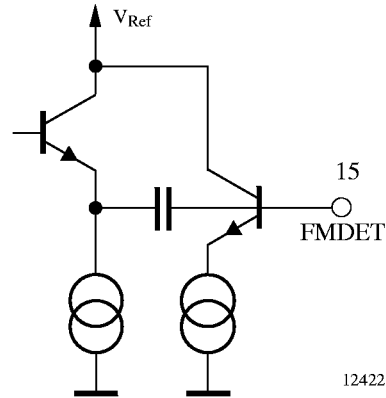

Figure 17.

An LC tank is connected between FMDET and VREF. The discriminator coil has to be adjusted so that the voltage at AFSM is 1.2 V at 10.7 MHz to ensure that the FM stop signal is generated correctly

FMIFIN

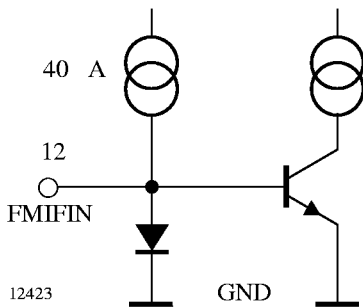

Figure 16.

The input impedance of the FM IF amplifier is 330 according to the required impedance of most FM ceramic filters. The input refers to GND (Pin 16).

AFSM

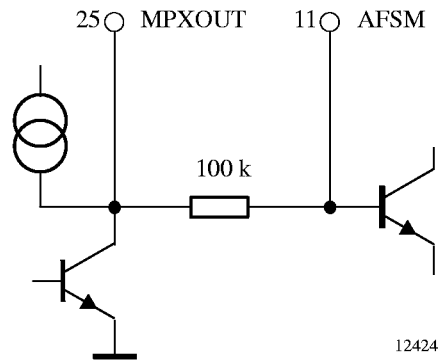

Figure 18.

A capacitor is connected between AFSM (Pin 11) and GND for smoothing the FM AF. As the deviation of the FM signal (75 kHz) might be greater than the stop-signal window (42 kHz), the FM-AF smoothing is necessary in order to generate a modulation-independent stop signal. In AM search mode, the external capacitor smoothes the FM demodulated AM IF signal.

METER

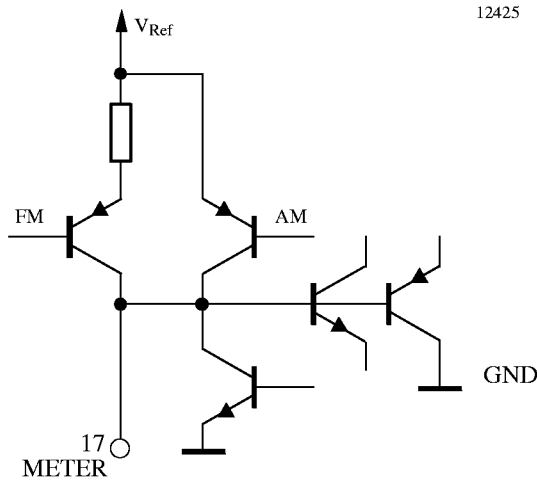

Figure 19.

This pin is driven by a current corresponding to the level of the FM- or AM IF signal. The required external load consists of a resistor (150 k Ω) in parallel with an external capacitor (e.g., 10 nF necessary to achieve a good THD in AM mode). The voltage at this pin controls the high cut and mono/ stereo blend function in reception mode. These functions can be affected by the designer by choosing different values of the load resistor.

CTRLA

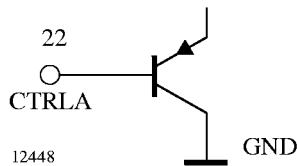

Figure 20.

Reception mode, search mode, and mute function as well as search sensitivity can be selected by applying a control voltage at CTRLA (Pin 22). If the control voltage is higher than 0.8 V, the receiver circuit is in reception mode, otherwise it is in search mode. When reducing the control voltage to a value between 1.3 and 0.8 V, the AF level output at OUTR, OUTL (Pins 18 and 19) is reduced (mute function). In search mode (0.7 to 0 V), the voltage value determines the degree of the search sensitivity.

CTRLB

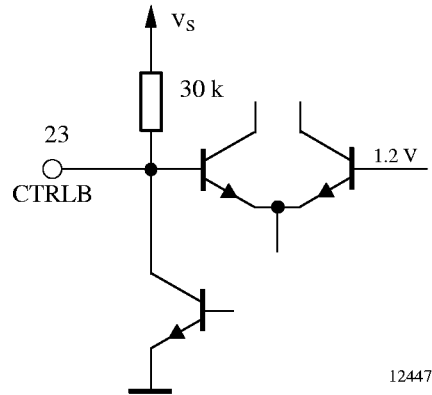

Figure 21.

The signal at the output CTRLB (Pin 23) indicates stereo or mono reception: stereo reception if the voltage is higher than 1.2 V, otherwise mono. Furthermore, it is possible to force the receiver circuit to mono by applying an external control voltage < 0.8 V at CTRLB. If search mode is selected, the low active stop signal appears at CTRLB. If the output CTRLB is connected directly to the I/O-port of the microcontroller, the high level of CTRLB has to be adapted by connecting a resistor between CTRLB and GND.

VREF

An internal voltage regulator generates a stable reference voltage of 2.4 V which is needed for all function blocks of the IC. An external capacitor has to be connected to GND in order to achieve stability and noise suppression.

AMFM

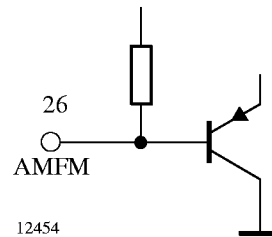

Figure 22.

By applying GND ($V_{AMFM} < 1.1$ V) at AMFM (Pin 26), the receiver circuit is switched to AM mode. If Pin AMFM is open, FM mode is selected. This switching function can easily be performed by a microcontroller with "open-drain" I/O-ports. A capacitor has to be connected between AMFM and GND for FM mode operation. It serves for smoothing the control voltage of the pilot canceller.

CERES

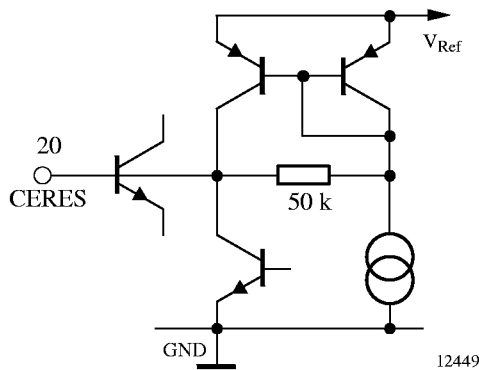

Figure 23.

A ceramic resonator of 456 kHz parallel resonance frequency (at 30 pF chip-internal load capacitance) is connected between CERES (Pin 20) and GND (necessary for the pilot regeneration). It should be mounted very close to Pin 20 in order to avoid spurious radiation. In AM ($V_{AMFM} < 1.1 \text{ V}$) search ($V_{CTRLA} < 0.8 \text{ V}$) mode, the resonator is used for stop-signal generation. The parallel resonance frequency is then reduced to 455 kHz by adjusting the current into AMSADJ (Pin 9).

LPF

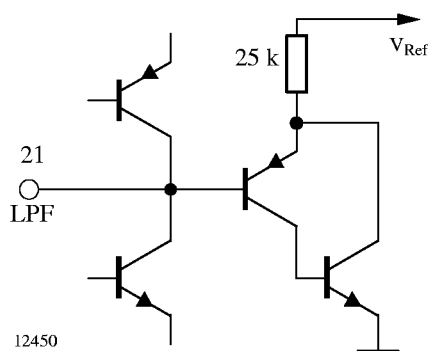

Figure 24.

A PLL circuit is used for the pilot regeneration of the stereo decoder. Therefore, a loop filter consisting of an RC network is connected between LPF (Pin 21) and GND.

MPXIN

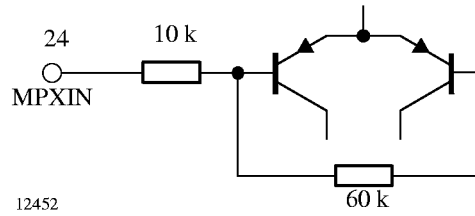

Figure 25.

The MPX signal is applied to MPXIN (Pin 24) and is fed to the stereo decoder. The input resistance into Pin 24 is approximately 10 kΩ. It is recommended to align the channel separation by an RC network between MPXIN and MPXOUT (Pin 25) due to the tolerances in group delay of the IF filter.

MPXOUT

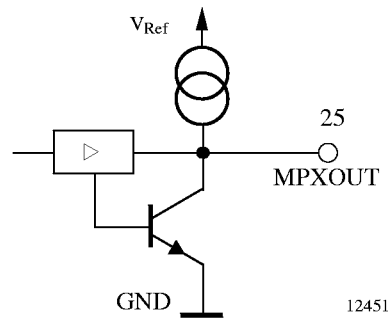

Figure 26.

In order to drive both the compensation network to MPXIN (Pin 24) and an optional RDS decoder, the MPXOUT (Pin 25) has a low output impedance. The DC level is 1.2 V in FM mode (depending on the discriminator coil alignment) and 0.8 to 1.2 V in AM mode (depending on the signal level).

OUTR/OUTL

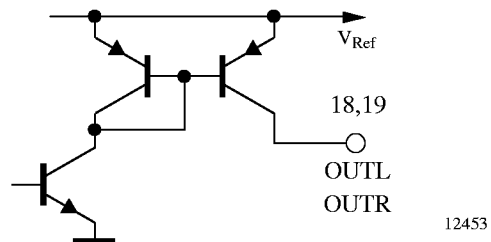

Figure 27.

The open-collector output of OUTR/OUTL (Pins 18 and 19) requires an external resistor of about 5.1 kΩ to ground. The deemphasis may be achieved by an additional parallel capacitor.

Functional Description

FM

The antenna signal is fed via a tuned RF circuit to the integrated pre-stage which consists of a transistor-grounded base circuit. To protect the pre-stage against overload, an automatic gain control (AGC) is included on the chip.

A tuned RF circuit on the collector is necessary for amplifying and filtering the FM signal which is fed internally to the mixer. It consists of a double-balanced Gilbert Cell.

The LO signal is generated by an integrated oscillator. The buffered LO signal is used to drive a PLL. The IF signal (10.7 MHz) is coupled out at the mixer's output and fed via a ceramic filter to the demodulator. The demodulated AF signal is available at MPXOUT.

AM

The antenna signal is fed directly to the mixer. The antenna impedance must be higher than 25 k to ensure correct operation of the level control in case of large signals. The LO signal is generated by an integrated oscillator. The buffered LO signal is used to drive the PLL. If AM search mode is required, the IF must be 455 kHz. The IF output signal is fed via a ceramic filter to the demodulator. The demodulated AF signal is available at MPXOUT.

CTRLA

By applying a control voltage at pin CTRLA, the mode of the receiver can be selected.

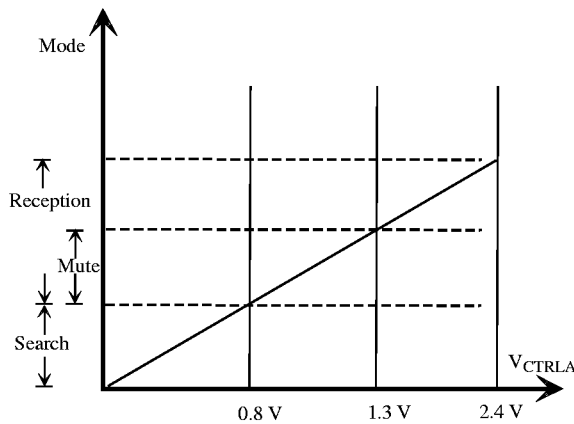

Figure 28.

Search Mode

The search mode is selected by applying a control voltage less than 0.8 V at pin CTRLA.

The search sensitivity can be chosen by varying the control voltage in the range of 0.1 to 0.8 V. If the control voltage is 0.1 V, the highest sensitivity is achieved.

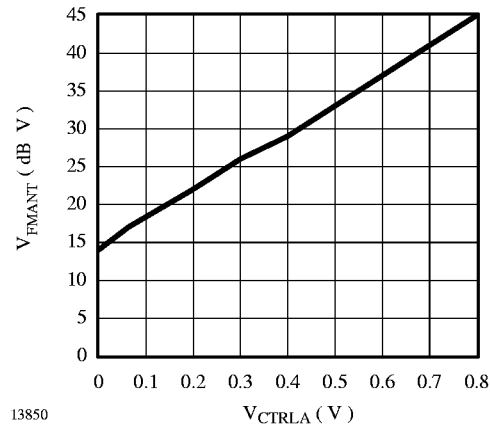

Figure 29. Adjustable FM stop-signal sensitivity

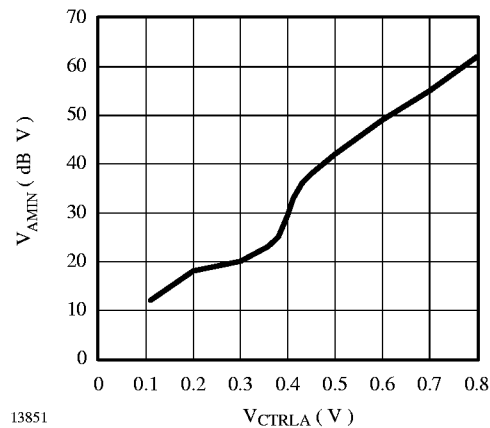

Figure 30. Adjustable AM stop-signal sensitivity

Reception Mode

In reception mode, muting is possible by varying the control voltage in the range of 1.4 to 0.8 V. If the control voltage is 0.8 V, the highest mute depth is achieved.

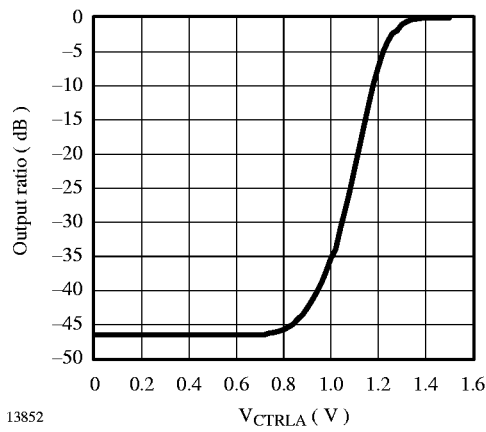

Figure 31. Mute function

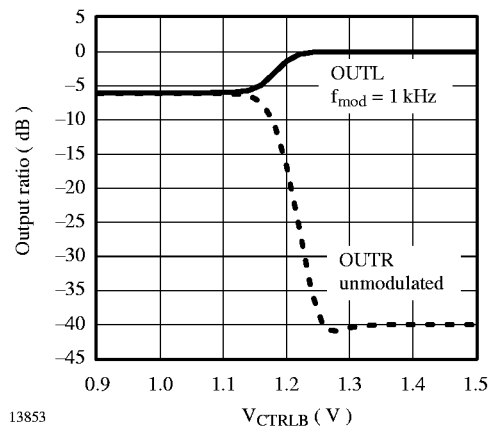

Figure 33. Forced mono function

CTRLB

The output CTRLB indicates whether the receiver is operating in mono or stereo mode.

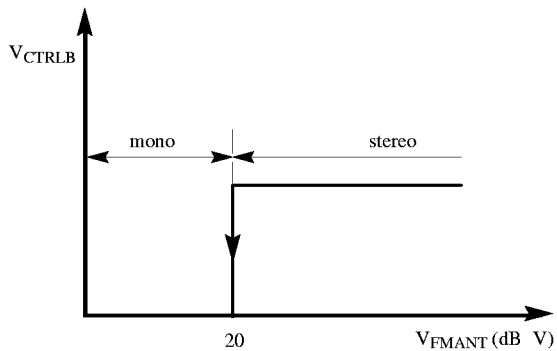

Figure 32.

If a control voltage less than 1.1 V is applied at CTRLB, the receiver is forced to mono.

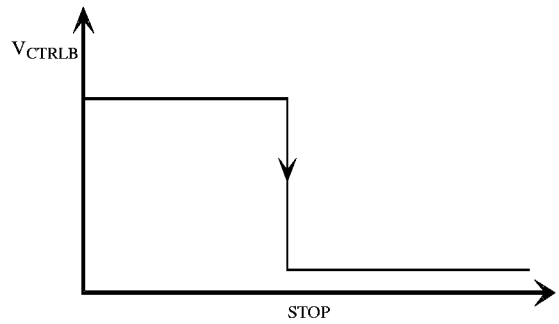

Figure 34.

In search mode ($V_{CTRLA} < 0.8$ V), the internally generated stop signal is available at CTRLB as low active signal.

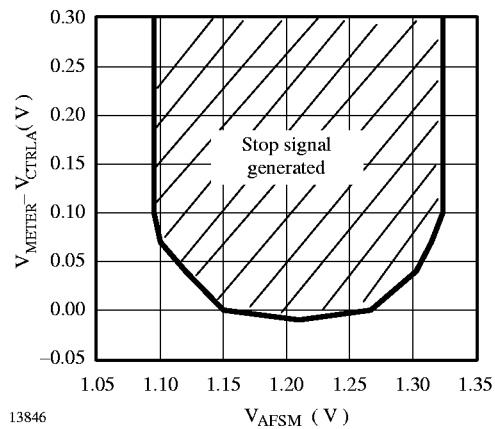
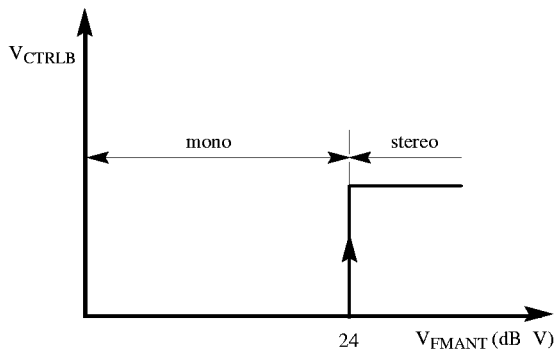

Figure 35. Stop signal in AM search mode

Stop Signal Conditions

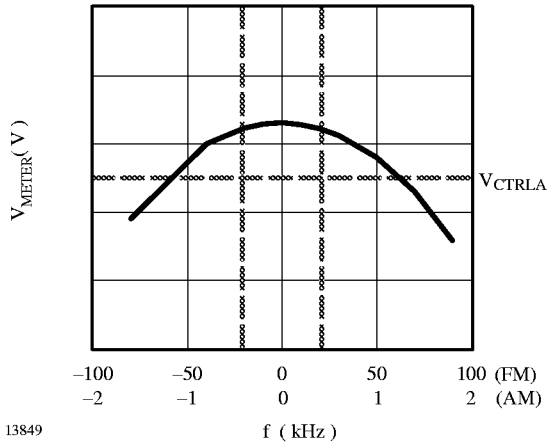

Figure 36. Field-strength tuning characteristic

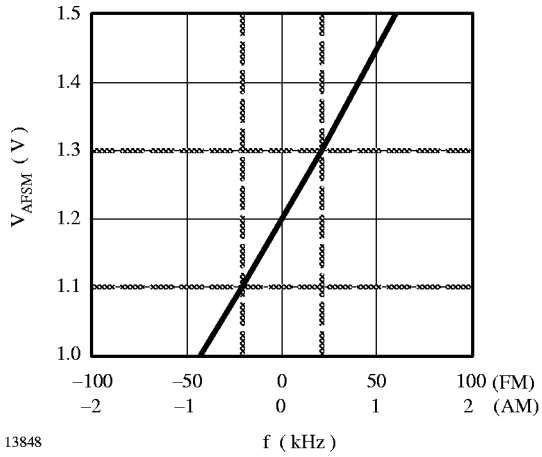

Figure 37. Smoothed S-curve

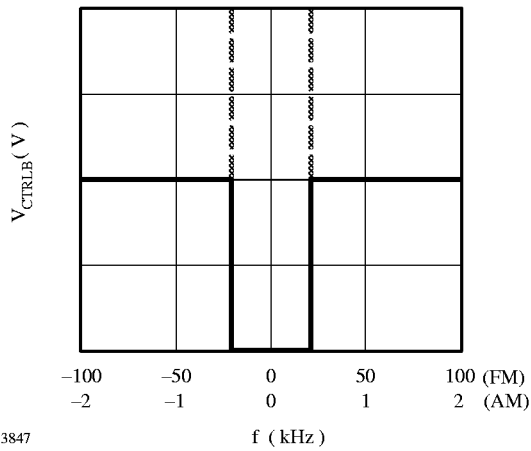

Figure 38. Stop signal

If both conditions

for AM: $V_{METER} > V_{CTRLA}$

for FM: $V_{METER} > \frac{90 \text{ k}}{R8 \text{ at Pin 17}} V_{CTRLA}$

and

$1.1 \text{ V} < V_{AFSM} < 1.3 \text{ V}$

for AM: current adjust into AMSADJ for $f_{CERES} = 455 \text{ kHz}$

for FM: detector coil adjust to $V_{AFSM} = 1.2 \text{ V}$ for 10.7 MHz

are fulfilled,

a stop signal is generated.

Typical Characteristics ($T_{amb} = 25^{\circ}\text{C}$, unless otherwise specified)

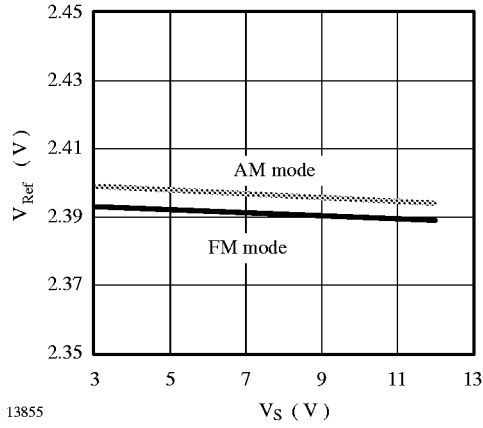

Figure 39. Supply-voltage characteristic of V_{Ref}

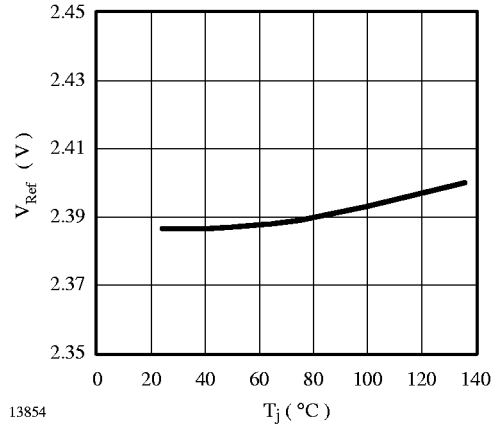

Figure 42. Temperature characteristic of V_{Ref}

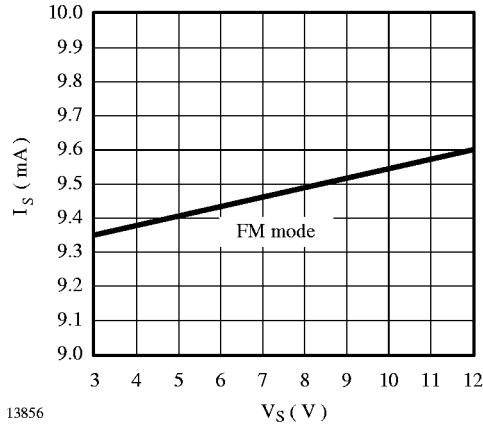

Figure 40. Supply-current characteristic

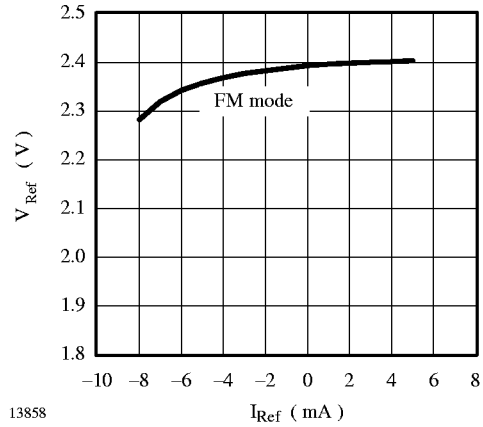

Figure 43. Load characteristic of V_{Ref}

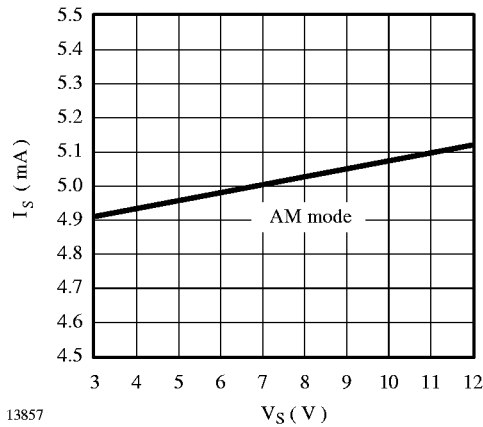

Figure 41. Supply-current characteristic

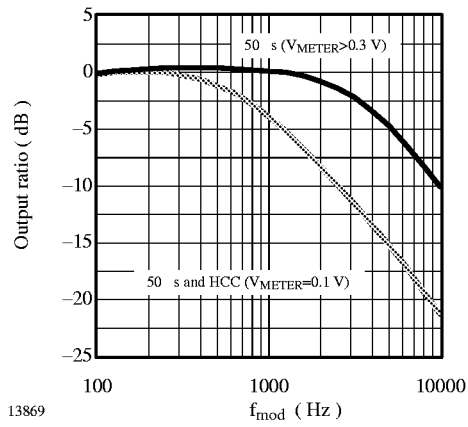
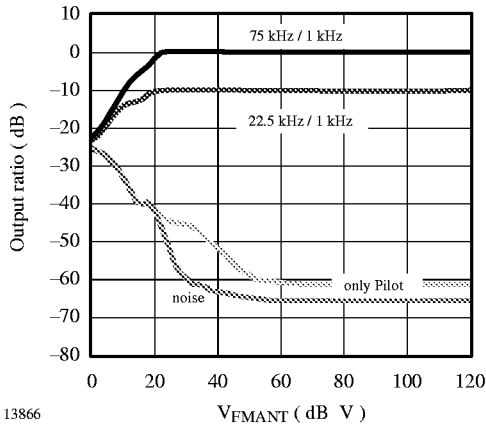
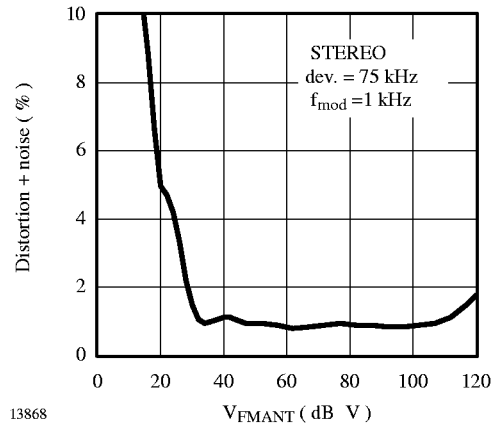

Figure 44. High-cut control (HCC)



13866

Figure 45. FM signal and noise characteristic



13868

Figure 48. FM signal and noise characteristic

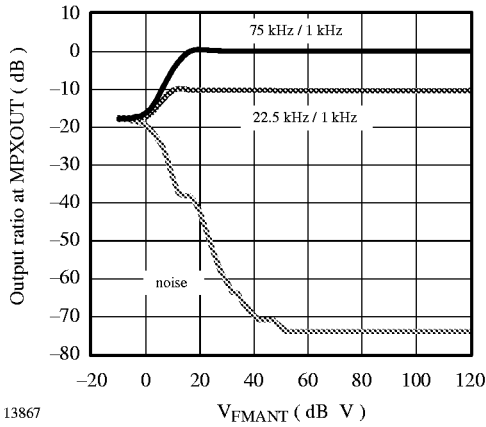

13867

Figure 46. FM signal and noise characteristic

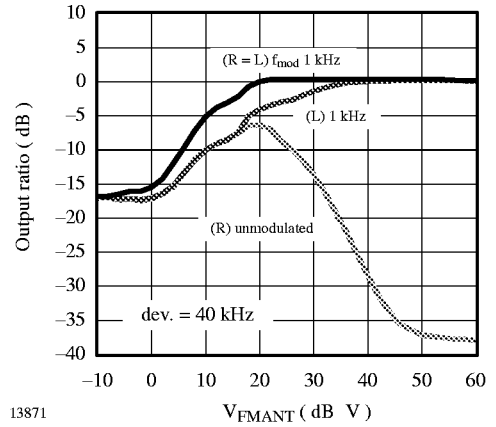

13871

Figure 49. Channel-separation characteristic

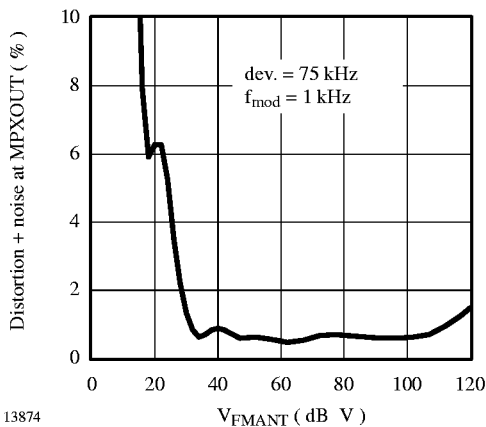

13874

Figure 47. FM distortion and noise characteristic at MPXOUT

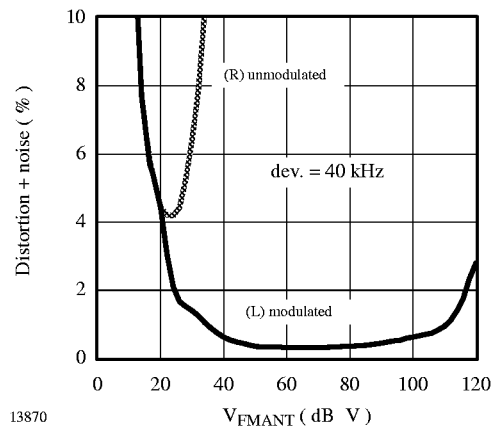

13870

Figure 50. Transition from mono to stereo

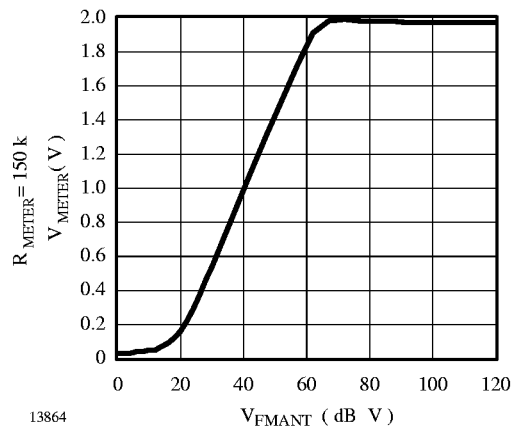

Figure 51. FM field-strength characteristic

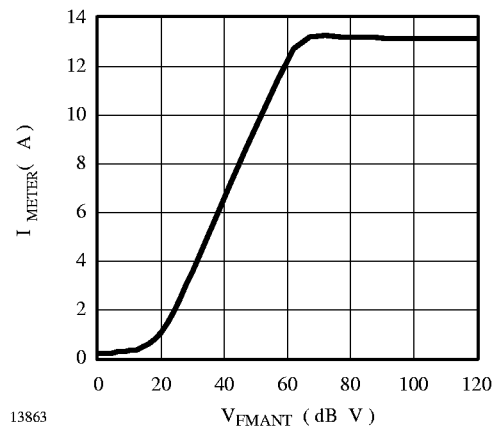

Figure 54. FM field-strength characteristic

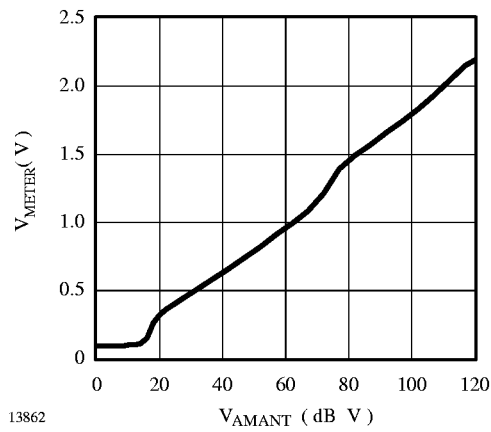

Figure 52. AM field-strength characteristic

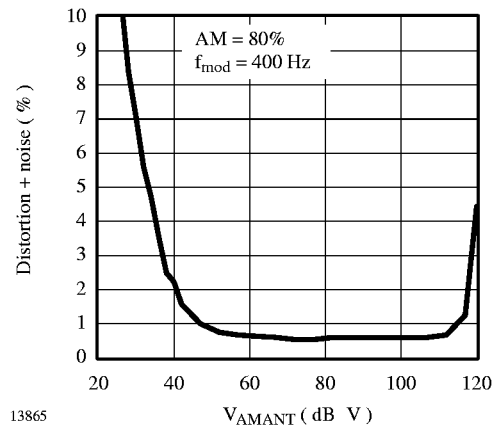

Figure 55. AM distortion and noise characteristic

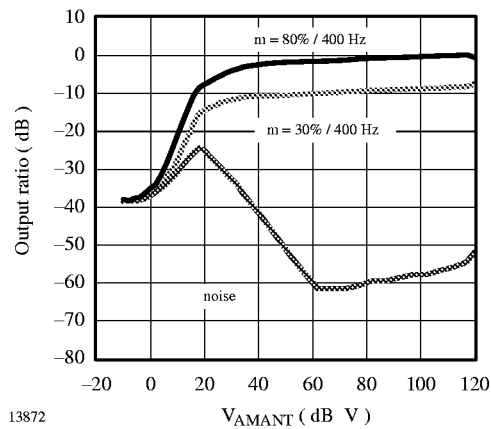

Figure 53. AM signal and noise characteristic

Absolute Maximum Ratings

Reference point Pin 16 and 4, unless otherwise specified

Parameters	Symbol	Value	Unit
Supply voltage	V_S		V
Power dissipation	P	750	mW
Junction temperature	T_j	125	°C
Storage temperature	T_{stg}	25 to 125	°C
Ambient temperature	T_{amb}	30 to 85	°C
Electrostatic handling	$\pm V_{ESD}$	2000	V

Thermal Resistance

Parameters	Symbol	Value	Unit
Junction ambient when soldered to PCB	R_{thJA}	125	K/W

Electrical Characteristics

$V_S = 6\text{ V}$, $T_{amb} = 25^\circ\text{C}$; reference point Pins 4 or 16, unless otherwise specified

Parameters	Test Conditions / Pins	Symbol	Min.	Typ.	Max.	Unit
DC supply						
Supply-voltage range	Pin 27	V_S	3.0		12.0	V
Supply current (AM)	Pin 27	I_S		5		mA
Supply current (FM)		I_S		9		mA
Reference output voltage	Pin 14	V_{Ref}	2.3	2.4	2.5	V
CTRLA Pin 22						
Input voltage		V_{CTRLA}				
Search mode			0		0.7	V
Reception mode			0.8		V_S	V
Mute function			0.8		1.4	V
CTRLB Pin 23						
Output voltage Mono	Reception mode	V_{CTRLB}	0		1.1	V
Stereo	$V_{CTRLA} > 0.8\text{ V}$		1.2		V_S	V
Stop signal Low	Search mode, $V_{CTRLA} < 0.8\text{ V}$	V_{CTRLB}	0		0.6	V
Stop window (AM)	$f_{center} = 455\text{ kHz}$ adjusted at AMSADJ	f		1.2		kHz
(FM)	$f_{center} = 10.7\text{ MHz}$, $V_{AFSM} = 1.2\text{ V}$	f		42		kHz
Input voltage forced mono		V_{CTRLB}	0		1.1	V
AMFM Pin 26						
Input voltage (AM)		V_{AMFM}	0		1.1	V
(FM)	open					
OSCOUT Pin 8						
Output voltage (AM)		V_{OSCOUT}		120		mV _{rms}
(FM)	$f_{LO} = 110\text{ MHz}$, unloaded			150		mV _{rms}
DC current (AM)		I_{OSCOUT}		0.3		mA
(FM)				0.7		mA

Parameters	Test Conditions / Pins	Symbol	Min.	Typ.	Max.	Unit
METER Pin 17 (see figures 51 and 52)						
Usable meter range (FM)				40		dB
(AM)				110		dB
MPXOUT Pin 25						
Output voltage (AM)	$f_{AMANT} = 1 \text{ MHz}$, $f_{mod} = 1 \text{ kHz}$, $m = 0.3$ $R_{AMANT} = 25 \text{ k}$, $V_{CTRLA} = 1.7 \text{ V}$, $V_{AMANT} = 20 \text{ dB V}$ $V_{AMANT} = 40 \text{ dB V}$ $V_{AMANT} = 100 \text{ dB V}$	V_{MPXOUT}		35 54 66		mV_{rms} mV_{rms} mV_{rms}
Total distortion	$V_{AMANT} = 100 \text{ dB V}$	d		0.7		%
Signal plus noise-to-noise	$V_{AMANT} = 40 \text{ dB V}$ $V_{AMANT} = 100 \text{ dB V}$	(S+N)/N		27 47		dB dB
Sensitivity (AM)	(S+N)/N = 26 dB	V_{AMANT}		38		dB V
Output voltage (FM)	$f_{FMANT} = 98 \text{ MHz}$, dev. = 75 kHz, $f_{mod} = 1 \text{ kHz}$	V_{MPXOUT}		220		mV_{rms}
Sensitivity (FM)	(S+N)/N = 26 dB	V_{FMANT}		12		dB V
MPXIN Pin 24						
Input resistance		R_{MPXIN}		10		k
OUTL, OUTR Pin 18/19						
AF output current	dev. = 75 kHz, $f_{mod} = 1 \text{ kHz}$, $V_{FMIN} = 60 \text{ dB V}$, $f_{FMIN} = 98 \text{ MHz}$	I_{OUT}		15		A
DC		I_{DC-OUT}		150		A
Muting attenuation		M		40		dB
Channel separation		CH		26		dB
Pilot-signal suppression		19kHz		28		dB
Ripple rejection	1 kHz / 100 mV_{rms}	Rip		50		dB
CERES Pin 20						
PLL oscillator frequency		f_{CERES}		456		kHz
FMRF Pin 3						
Impedance	$f = 98 \text{ MHz}$	C_p R_p		6.7 9.5		pF k
DC current	See figure 5	I_{FMRF}		1		mA
Voltage-gain preamplifier	$20 \log(V_{FMRF}/V_{FMANT})$	g_{Preamp}		16		dB
AGC threshold	3 dB compression	V_{FMRF}		66		dB V
IFOUT Pin 10						
DC current (AM)		I_{IFOUT}		50		A
(FM)				0.4		mA
Conversion gain	$20 \log(V_{IFOUT}/V_{FMIFIN})$	g_{IFOUT}		20		dB
FMIFIN Pin 12						
Input impedance		r_{FMIFIN}		330		
AMIFIN Pin 13						
Input resistor		R_{AMIFIN}		3		k

Block Diagrams for Interface between U2514B and the Microcontroller

a) with external PLL (e.g., U4285BM)

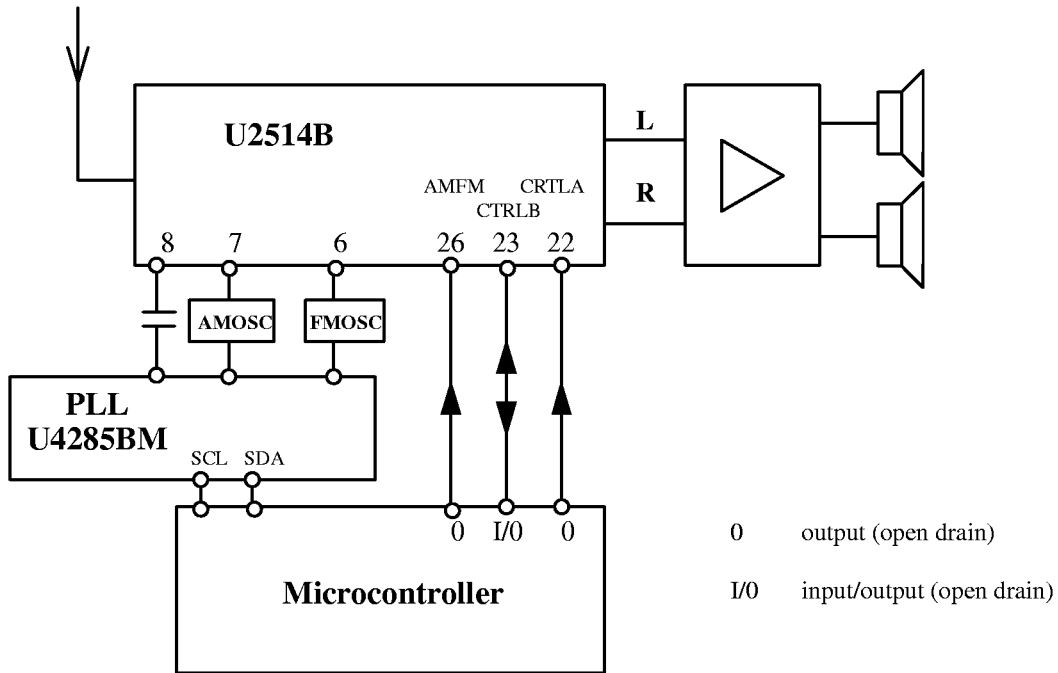

Figure 56.

b) microcontroller with built-in PLL

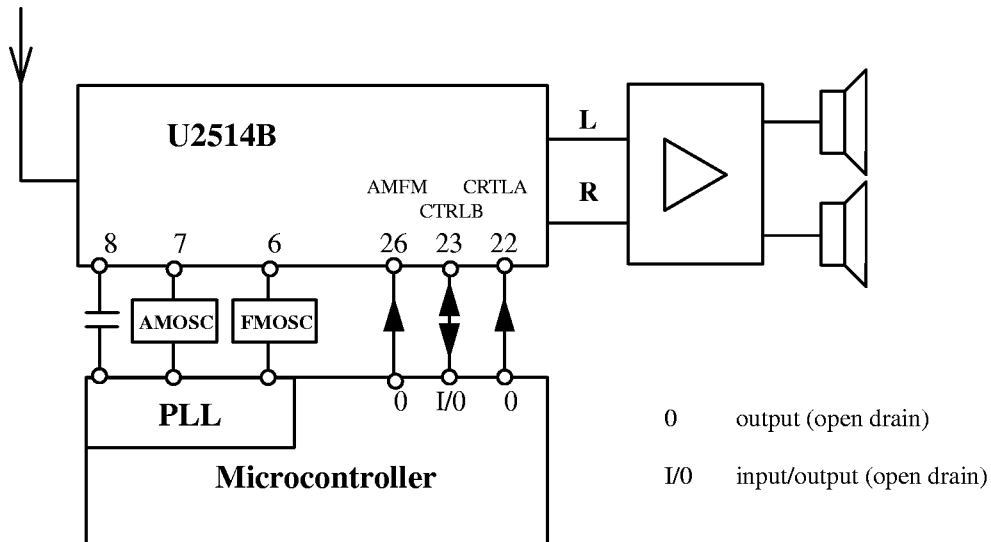
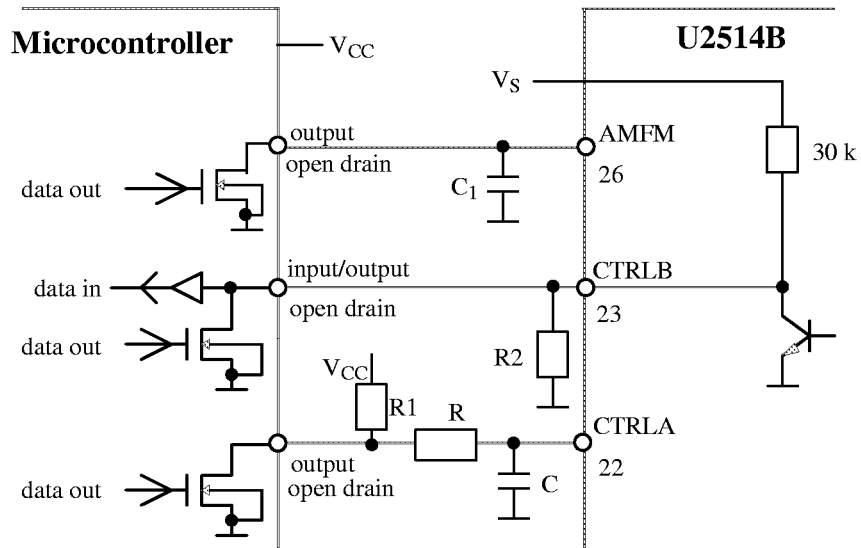

Figure 57.



I/O Ports of microcontroller

Figure 58.

The search-mode sensitivity is adjustable at CTRLA by applying a DC voltage. This voltage can be generated by PWM and smoothed by the RC combination corresponding to figure 58.

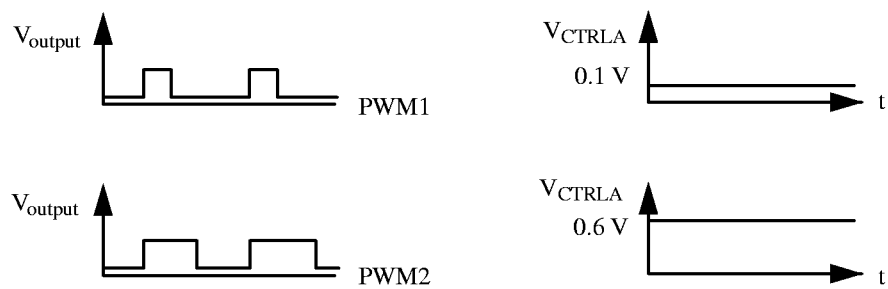

Figure 59.

Application Circuit with PLL

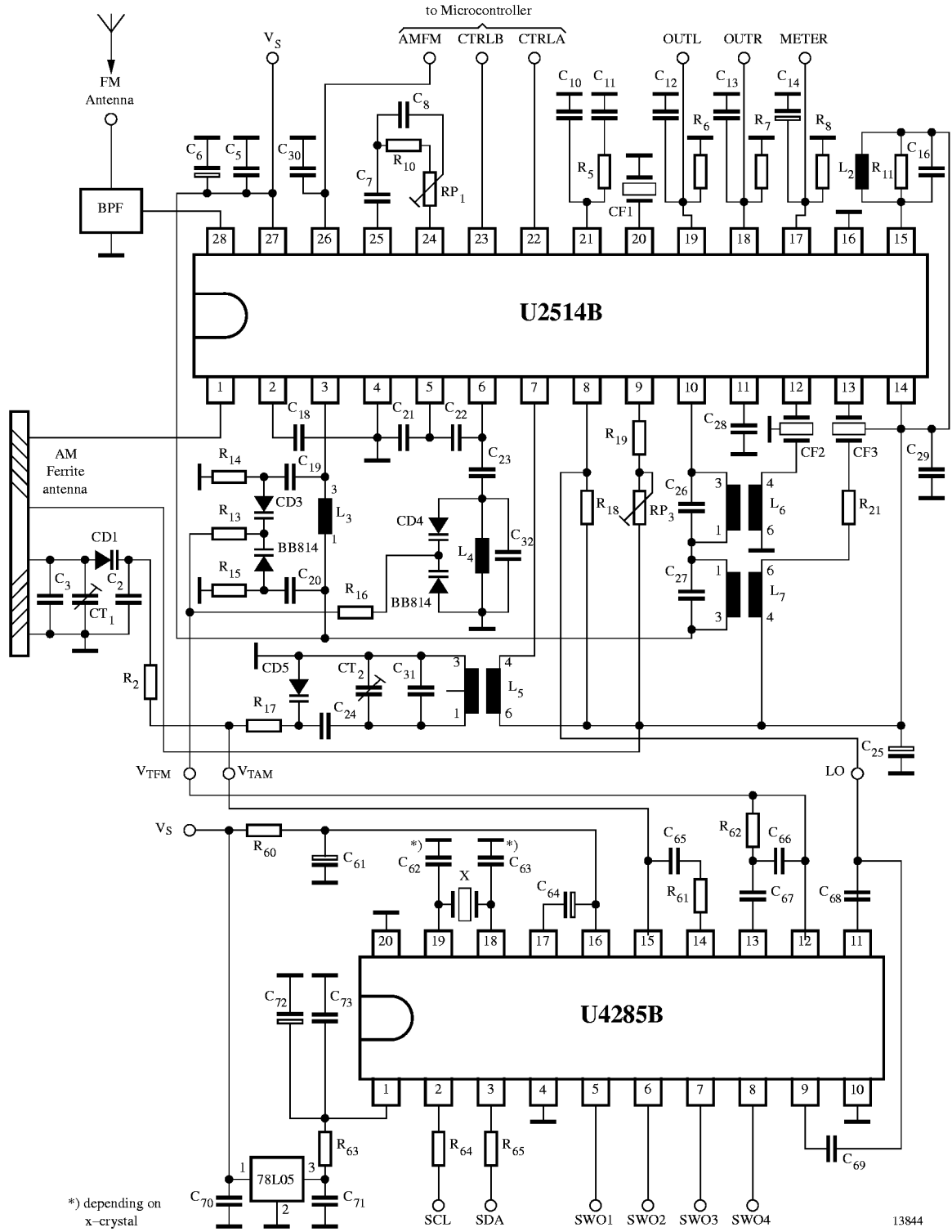

Figure 60.

Test Circuit

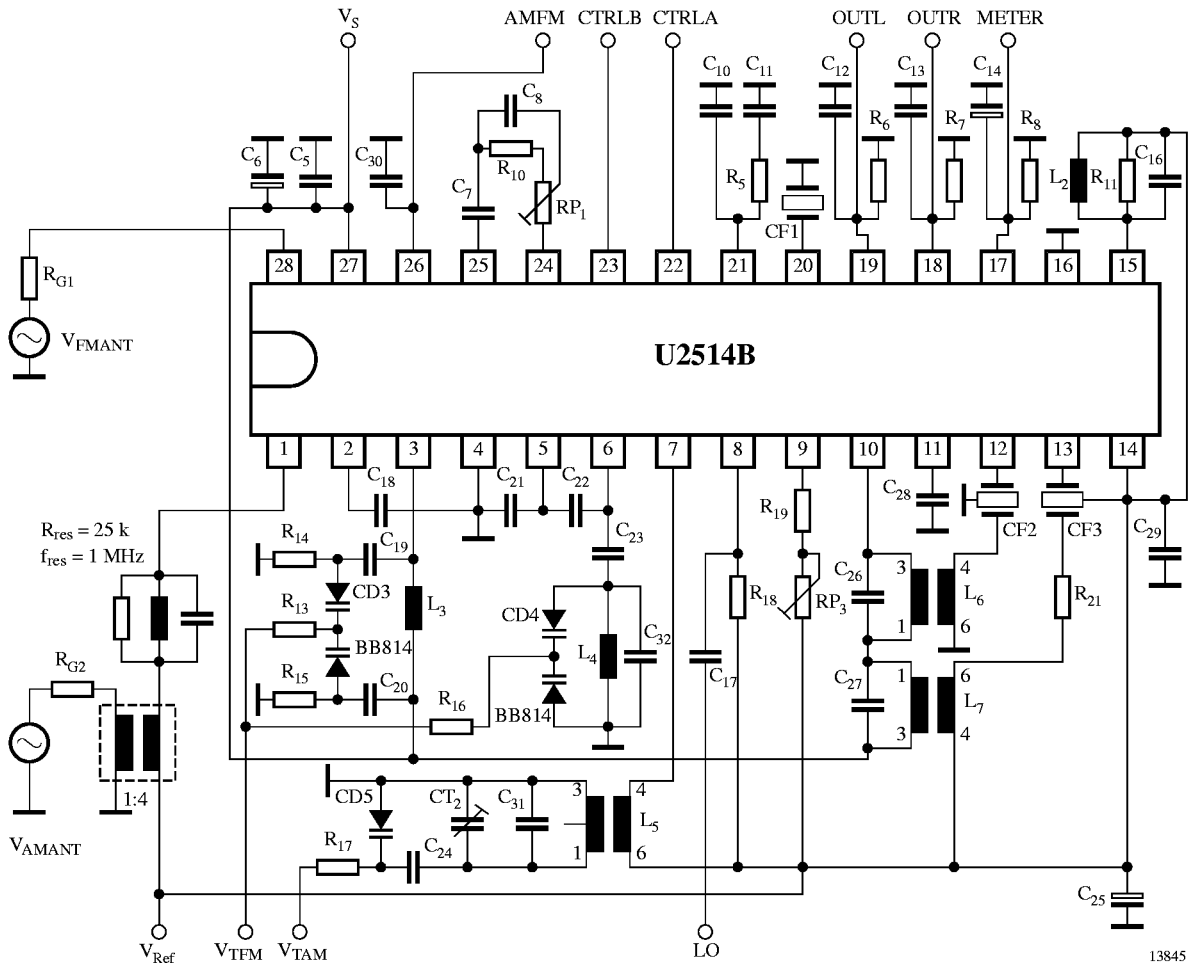

Figure 61.

Component List

	Figure 60	Figure 61
C ₁	–	–
C ₂	15 nF	–
C ₃	10 pF	–
C ₄	–	–
C ₅	100 nF	100 nF
C ₆	10 F	10 F
C ₇	470 nF	470 nF
C ₈	100 pF	100 pF
C ₁₀	6.8 nF	6.8 nF
C ₁₁	68 nF	68 nF
C ₁₂	10 nF	10 nF
C ₁₃	10 nF	10 nF
C ₁₄	10 F	10 F
C ₁₆	100 pF	100 pF
C ₁₇	–	2.2 nF
C ₁₈	100 nF	100 nF
C ₁₉	2.2 nF	2.2 nF
C ₂₀	2.2 nF	2.2 nF
C ₂₁	10 pF	10 pF
C ₂₂	22 pF	22 pF
C ₂₃	10 pF	10 pF
C ₂₄	390 pF	390 pF
C ₂₅	100 F	100 F
C ₂₆	100 pF	100 pF
C ₂₇	180 pF	180 pF
C ₂₈	100 nF	100 nF
C ₂₉	100 nF	100 nF
C ₃₀	100 nF	100 nF
C ₃₁	15 pF	15 pF
C ₃₂	3.9 pF	3.9 pF
C ₆₁	100 F	–
C ₆₂	depending on x-crystal	–
C ₆₃	depending on x-crystal	–
C ₆₄	100 F	–
C ₆₅	100 nF	–
C ₆₆	270 pF	–
C ₆₇	10 nF	–
C ₆₈	2.2 nF	–

	Figure 60	Figure 61
C ₆₉	100 pF	–
C ₇₀	100 nF	–
C ₇₁	100 nF	–
C ₇₂	100 F	–
C ₇₃	100 nF	–
CT1	15 pF	–
CT2	15 pF	15 pF
CD1	KV1591A-2	–
CD3	BB814	BB814
CD4	BB814	BB814
CD5	KV1591A-2	KV1591A
CD8	–	–
R ₁	–	–
R ₂	100 k	–
R ₅	330 k	330 k
R ₆	5.1 k	5.1 k
R ₇	5.1 k	5.1 k
R ₈	150 k	150 k
R ₁₀	33 k	33 k
R ₁₁	6.8 k	6.8 k
R ₁₃	56 k	56 k
R ₁₄	56 k	56 k
R ₁₅	10 k	10 k
R ₁₆	10 k	10 k
R ₁₇	100 k	100 k
R ₁₈	470	470
R ₁₉	10 k	10 k
R ₂₁	1.8 k	1.8 k
R ₆₀	220	–
R ₆₁	56 k	–
R ₆₂	5.6 k	–
R ₆₃	22	–
R ₆₄	12 k	–
R ₆₅	12 k	–
R _{G1}	–	75
R _{G2}	–	50
RP1	20 k	20 k
RP3	100 k	100 k
X	4 MHz	–

Recommended Coils and Filters for the U2514B Application

BPF	FM antenna:	SOSHIN GFMB3
L ₃	FM RF:	TOKO 7KL-TYPE 291ENS 2054 IB
L ₄	FM oscillator:	TOKO 7KL-TYPE 291ENS 2054 IB
L ₂ + C ₁₆	FM discriminator:	TOKO 7PH-TYPE A119ACS-19000Z
L ₆ + C ₂₆	FM IF:	TOKO 7PH-TYPE A119ACS-18999N
	CF1 ceramic resonator:	MURATA CSB 456 F10
CT ₂	FM ceramic IF filter:	10.7 MHz, Bw 180 kHz or 150 kHz
L ₅	AM oscillator:	TOKO 7P-TYPE A7BRS-12938X
L ₇ + C ₂₇	AM IF:	TOKO 7P-TYPE 7MC-312162NO
CT ₃	AM ceramic IF filter:	455 kHz
	AM capacitance diodes:	TOKO KV1591A-2
	AM bar antenna:	Lw1 = 220 H (59 turns, 10 0.04 mm flex wire) Rpw2 = 25 k (23 turns) if w1-circuit is in resonance at 1 MHz Ferrite material: diameter 10 mm, length 80 mm

The U2514B Meets all FCC Standards

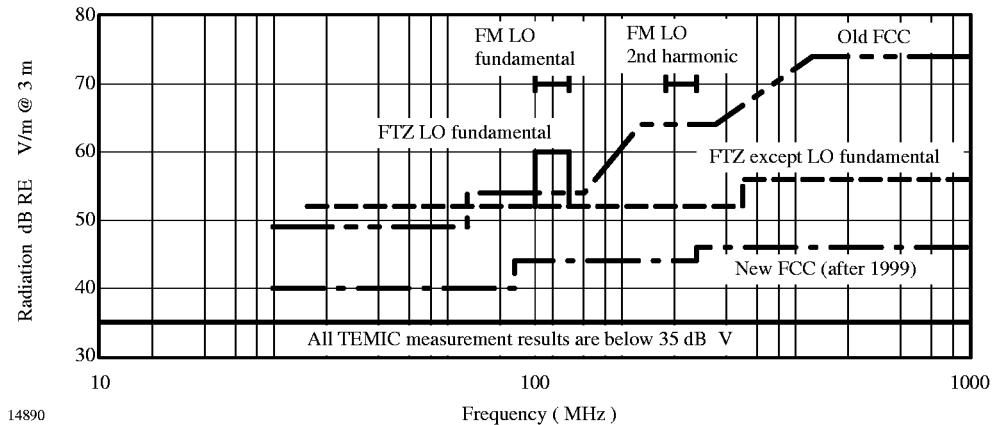
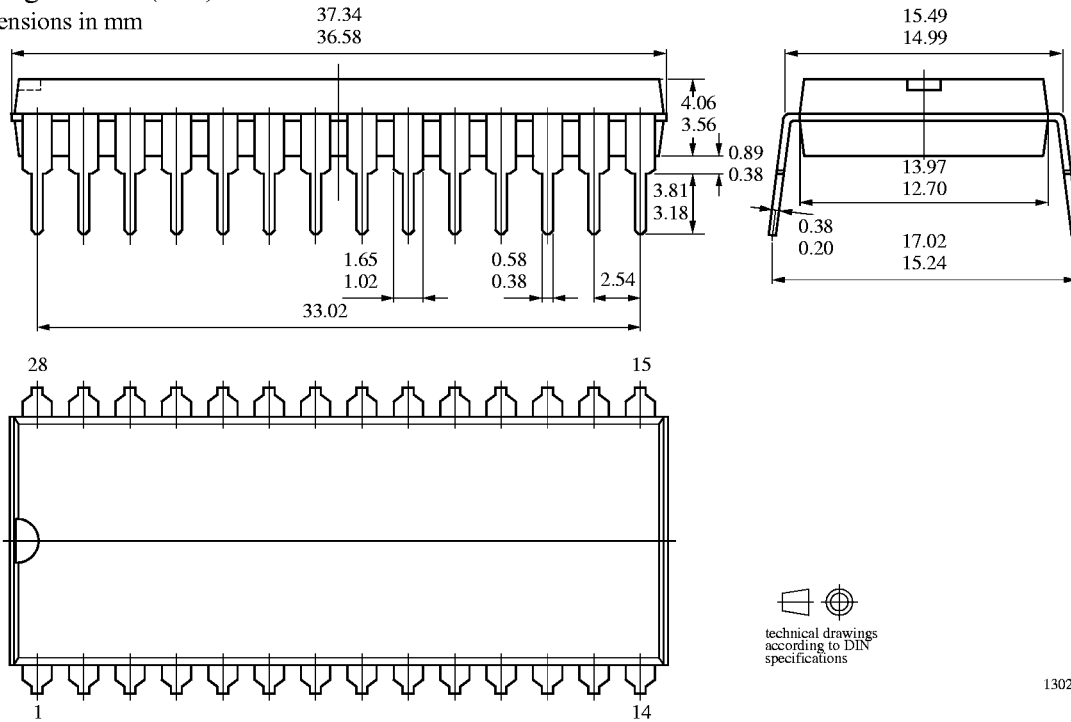

Figure 62. FCC measurements

Package Information

Package DIP28 (CEI)

Dimensions in mm



Package SSO28

Dimensions in mm

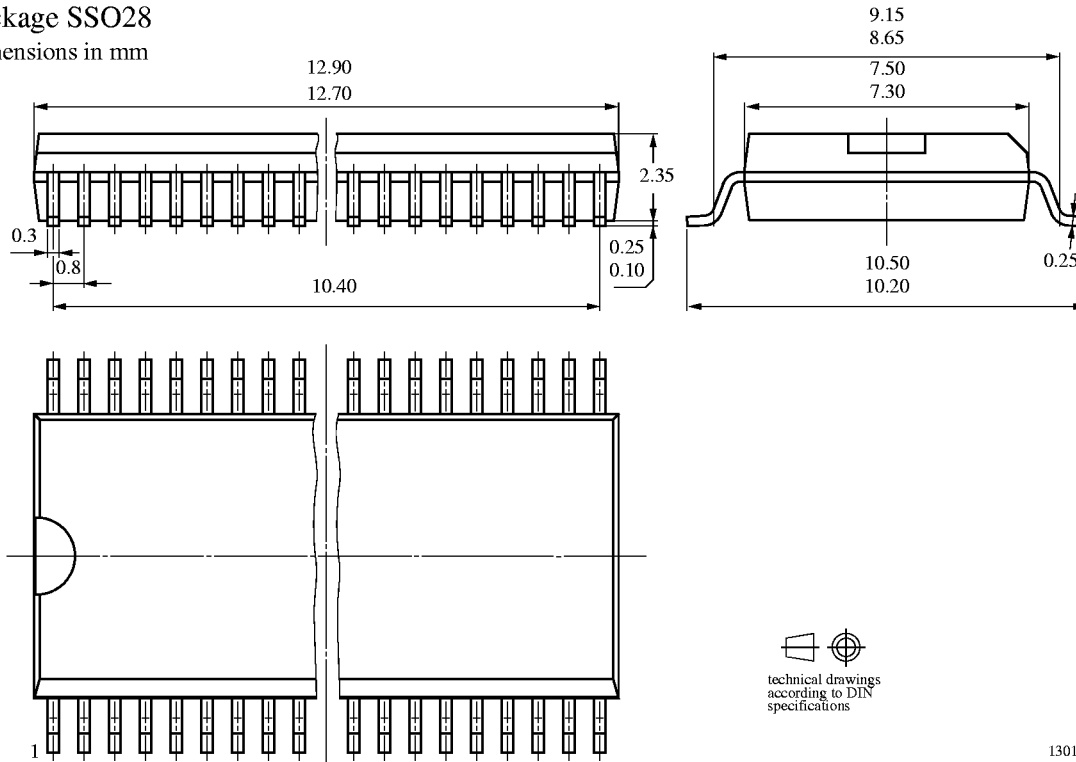

Ozone Depleting Substances Policy Statement

It is the policy of **TEMIC Semiconductor GmbH** to

1. Meet all present and future national and international statutory requirements.
2. Regularly and continuously improve the performance of our products, processes, distribution and operating systems with respect to their impact on the health and safety of our employees and the public, as well as their impact on the environment.

It is particular concern to control or eliminate releases of those substances into the atmosphere which are known as ozone depleting substances (ODSs).

The Montreal Protocol (1987) and its London Amendments (1990) intend to severely restrict the use of ODSs and forbid their use within the next ten years. Various national and international initiatives are pressing for an earlier ban on these substances.

TEMIC Semiconductor GmbH has been able to use its policy of continuous improvements to eliminate the use of ODSs listed in the following documents.

1. Annex A, B and list of transitional substances of the Montreal Protocol and the London Amendments respectively
2. Class I and II ozone depleting substances in the Clean Air Act Amendments of 1990 by the Environmental Protection Agency (EPA) in the USA
3. Council Decision 88/540/EEC and 91/690/EEC Annex A, B and C (transitional substances) respectively.

TEMIC Semiconductor GmbH can certify that our semiconductors are not manufactured with ozone depleting substances and do not contain such substances.

We reserve the right to make changes to improve technical design and may do so without further notice.

Parameters can vary in different applications. All operating parameters must be validated for each customer application by the customer. Should the buyer use TEMIC Semiconductors products for any unintended or unauthorized application, the buyer shall indemnify TEMIC Semiconductors against all claims, costs, damages, and expenses, arising out of, directly or indirectly, any claim of personal damage, injury or death associated with such unintended or unauthorized use.

TEMIC Semiconductor GmbH, P.O.B. 3535, D-74025 Heilbronn, Germany
Telephone: 49 (0)7131 67 2594, Fax number: 49 (0)7131 67 2423