



3.6 V GSM GaAs Integrated Power Amplifier

The MRFIC0919 is a single supply, RF power amplifier designed for the 2.0 W GSM900 handheld radio. The negative power supply is generated inside the chip using RF rectification, which avoids any spurious signal. A built in priority switch is provided to prevent Drain Voltage being applied on the RF lineup if not properly biased by the Negative Voltage. The device is packaged in the TSSOP-16EP package, with exposed backside pad, which allows excellent electrical and thermal performance through a solderable contact.

- Target 3.6 V Characteristics:
 - RF Input Power: 3.0 dBm
 - RF Output Power: 35.3 dBm Typical
 - Efficiency: 53% Typical
- Single Positive Supply Solution
- Negative Voltage Generator
- Positive Step-up Voltage Generator
- V_{SS} Check Switch for Gate-Drain Priority

MRFIC0919

GSM 880 – 915 MHz INTEGRATED POWER AMPLIFIER

SEMICONDUCTOR TECHNICAL DATA

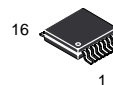

PLASTIC PACKAGE
CASE 948L
(TSSOP-16EP, Tape and Reel Only)

PIN CONNECTIONS

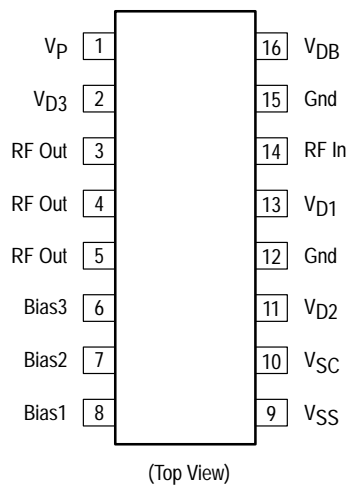

Simplified Block Diagram

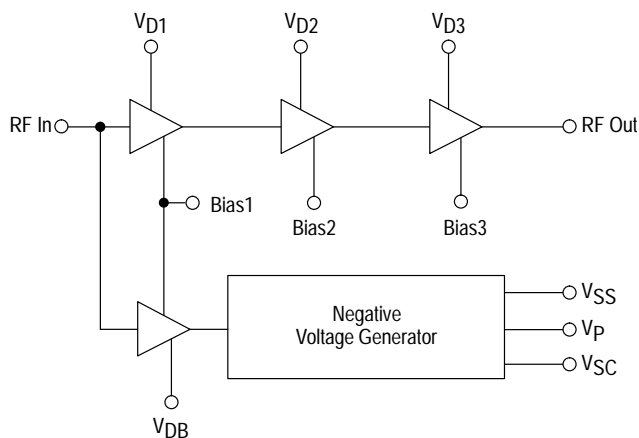

This device contains 8 active transistors.

ORDERING INFORMATION

Device	Operating Temp Range	Package
MRFIC0919R2	T _A = -40 to 85°C	TSSOP-16EP

Freescale Semiconductor, Inc. DEVICE ON LIFETIME BUY

LAST ORDER 04JUL02 LAST SHIP 04JAN02

MAXIMUM RATINGS

Rating	Symbol	Value	Unit
Supply Voltage	$V_{D1, 2, 3}$	6.0	V
RF Input Power	P_{in}	12	dBm
RF Output Power	P_{out}	38	dBm
Operating Case Temperature Range	T_C	-40 to 85	°C
Storage Temperature Range	T_{stg}	-55 to 150	°C

- NOTES:** 1. Maximum Ratings are those values beyond which damage to the device may occur. Functional operation should be restricted to the limits in the Recommended Operating Conditions or Electrical Characteristics tables.
 2. ESD (electrostatic discharge) immunity meets Human Body Model (HBM) ≤ 250 V and Machine Model (MM) ≤ 60 V. This device is rated Moisture Sensitivity Level (MSL) 4. Additional ESD data available upon request.

RECOMMENDED OPERATING CONDITIONS

Characteristic	Symbol	Min	Typ	Max	Unit
Supply Voltage	$V_{DB}, V_{D1, 2, 3}$	-	3.0 to 5.5	-	Vdc
Input Power	P_{in}	-	3.0 to 8.0	-	dBm

ELECTRICAL CHARACTERISTICS ($V_{DB} = 3.6$ V, $V_{D1, 2, 3} = 3.6$ V, $P_{in} = 3.0$ dBm, Peak measurement at 12.5% duty cycle, 4.6 ms Period, $T_A = 25^\circ\text{C}$, unless otherwise noted.)

Characteristic	Symbol	Min	Typ	Max	Unit
Frequency Range	BW	880	-	915	MHz
Output Power	P_{out}	34.5	35.3	-	dBm
Power Added Efficiency	PAE	45	53	-	%
Output Power at Low Voltage ($V_{D1, 2, 3} = 3.0$ V)	P_{out}	33	33.7	-	dBm
Harmonic Output					dBc
$2f_0$	-	-	40	35	
$\geq 3f_0$	-	-	45	40	
Input Return Loss	$ S_{11} $	-	12	-	dB
Output Power Isolation ($P_{in} = 8.0$ dBm, $V_{DB} = 3.0$ V, $V_{D1, 2\&3} = 0$ V)	P_{off}	-	-32	-	dBm
Noise Power in Rx band 925 to 960 MHz (100 kHz measurement bandwidth)	NP	-	-90	-	dBm
Negative Voltage ($P_{in} = 3.0$ dBm, $V_{DB} = 3.0$ V, $V_{D1, 2\&3} = 0$ V)	V_{SS}	-4.85	-	-	V
Negative Voltage Setting Time ($P_{in} = 3.0$ dBm, V_{DB} stepped from 0 to 3.0 V)	T_s	-	0.7	-	μs
Stability–Spurious Output ($P_{out} = 5.0$ to 35 dBm, Load VSWR 6:1 all phase angles, source VSWR = 3:1, at any phase angle, Adjust $V_{D1, 2\&3}$ for specified power)	P_{spur}	-	-	-60	dBc
Load Mismatch Stress ($P_{out} = 5.0$ to 35 dBm, Load VSWR = 10:1 all phase angles, 5 seconds, Adjust $V_{D1, 2\&3}$ for specified power)	No Degradation in Output Power Before & After Test				
Positive Voltage ($P_{in} = 3.0$ dBm, $V_{DB} = 3.0$ V)	V_P	6.0	-	-	V

Freescale Semiconductor, Inc. DEVICE ON LIFETIME BUY

LAST ORDER 04JUL02 LAST SHIP 04JAN02

Table 1. Optimum Loads Derived from Circuit Characterization

f MHz	Z _{in} OHMS		Z _{OL} [*] OHMS	
	R	jX	R	jX
880	9.83	-75.84	1.79	2.34
885	9.88	-76.75	1.78	2.46
890	9.83	-77.65	1.76	2.57
895	9.82	-78.60	1.75	2.67
900	9.82	-79.50	1.74	2.80
905	9.79	-80.35	1.73	2.90
910	9.78	-81.23	1.71	3.00
915	9.75	-82.18	1.70	3.13

Z_{in} represents the input impedance of the device.
Z_{OL}^{*} represents the conjugate of the optimum output load to present to the device.

Figure 1. Reference Circuit

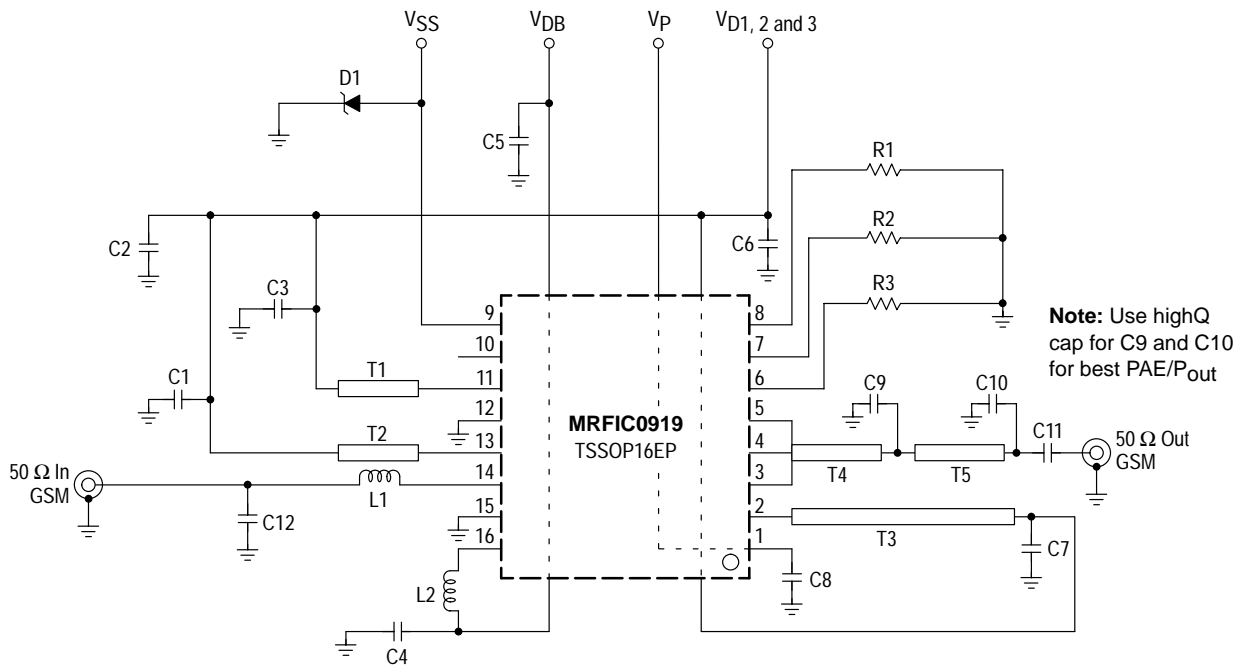

C1, C3, C4, C7, C11	56 pF	R1, R2	12 k
C2, C6	10 nF	R3	6.8 k
C5	330 pF	T1	60 Ω Microstrip Line, L = 3.0 mm
C8	4.7 pF	T2	60 Ω Microstrip Line, L = 11 mm
C9	12 pF	T3	50 Ω Microstrip Line, L = 17 mm
C10	6.8 pF	T4	30 Ω Microstrip Line, L = 1.0 mm
C12	8.2 pF	T5	30 Ω Microstrip Line, L = 7.0 mm
L1	12 nH		
L2	6.8 nH		
D1	Zener 5.1 V	MMSZ4689T1	

Figure 2. 3.6 V GSM IPA MRFIC0919 Application Circuit

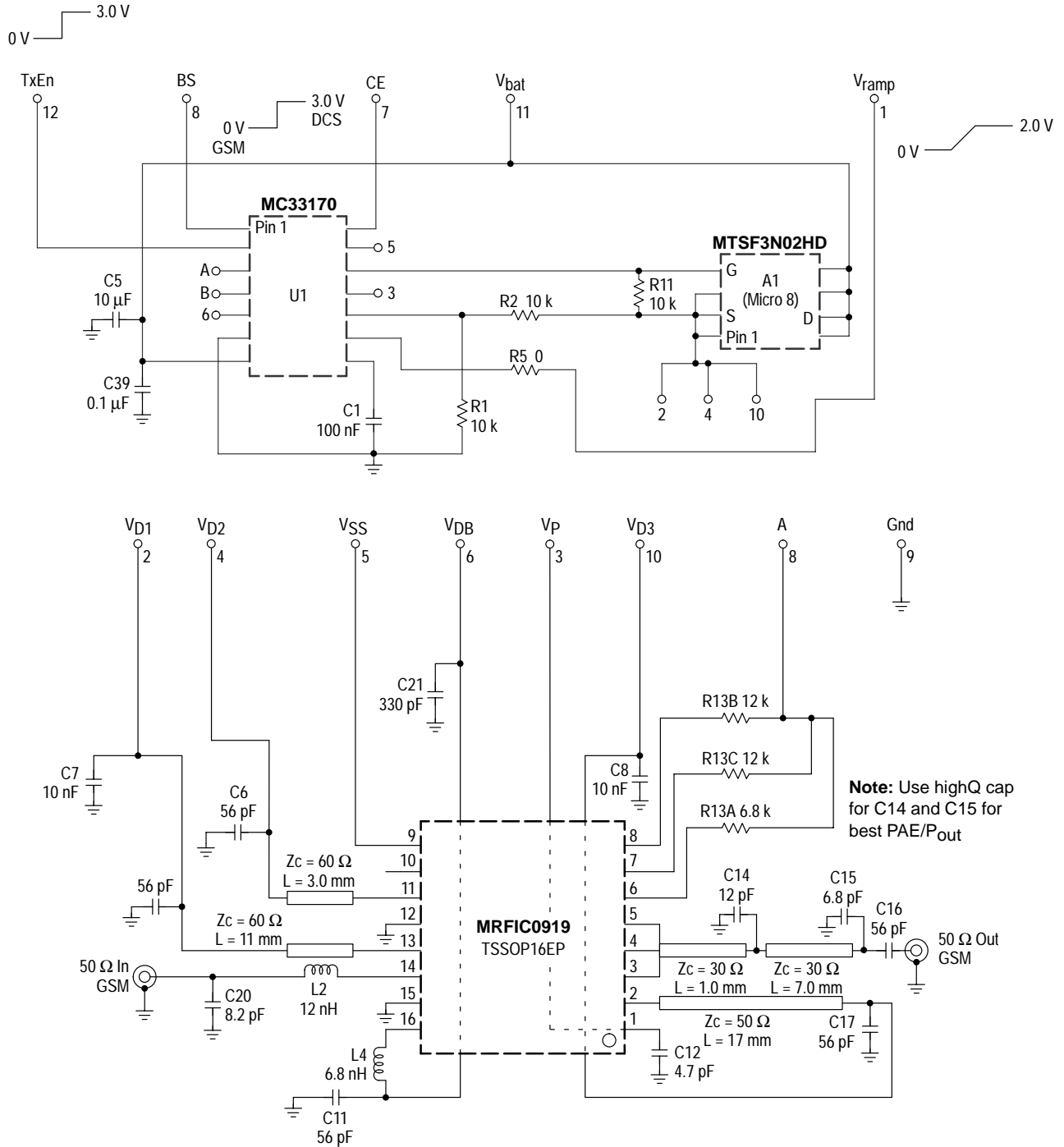

Note: I/O labels and pin numbers refer to demoboard connector pin out.

Freescale Semiconductor, Inc. DEVICE ON LIFETIME BUY

LAST ORDER 04JUL02 LAST SHIP 04JAN02

Figure 3. 3.6 V GSM & DCS IPA Dual-Band Application Circuit with Companion Chip & NMOS Switch

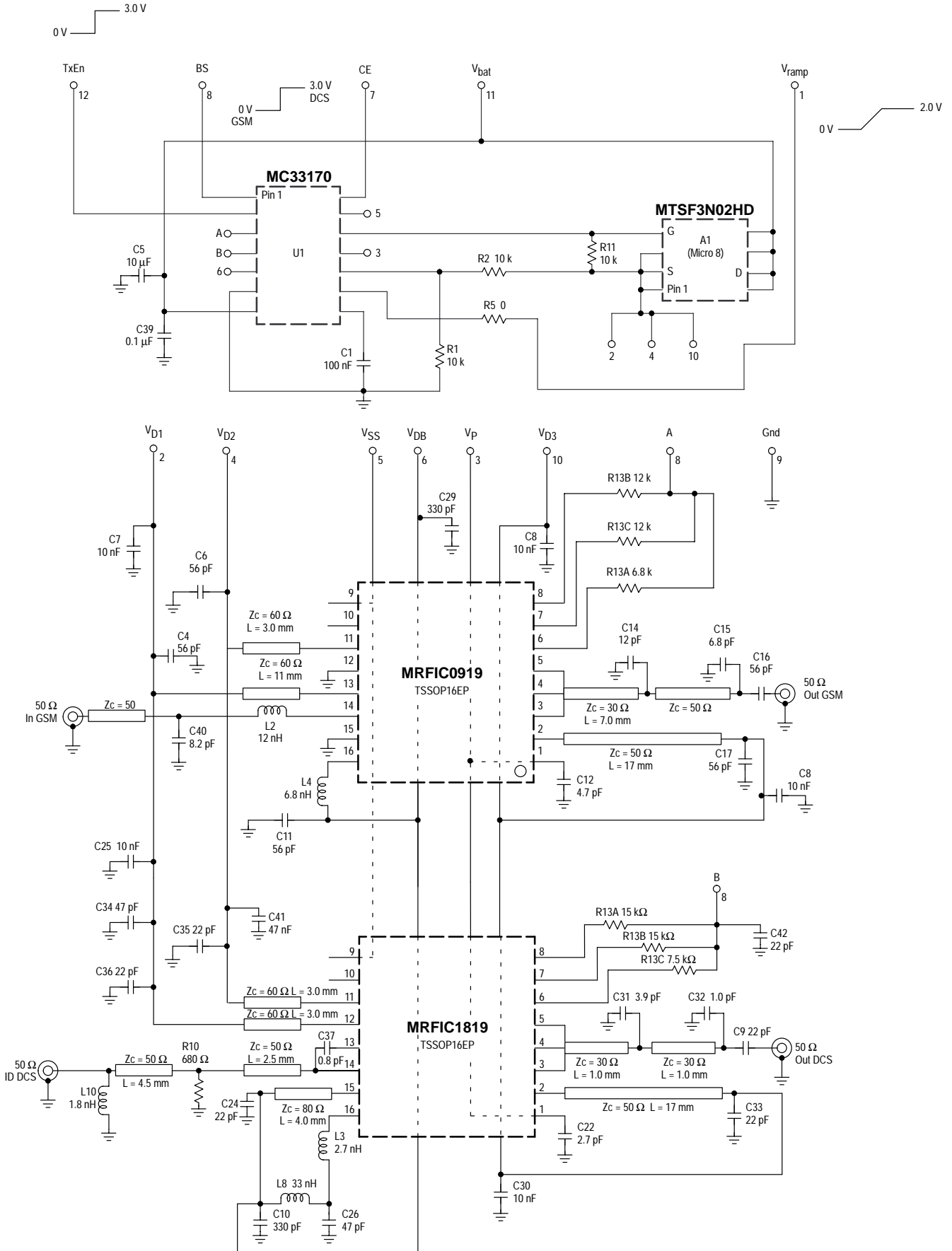

Freescale Semiconductor, Inc. DEVICE ON LIFETIME BUY

LAST ORDER 04JUL02 LAST SHIP 04JAN02

Figure 4. Output Power versus Frequency

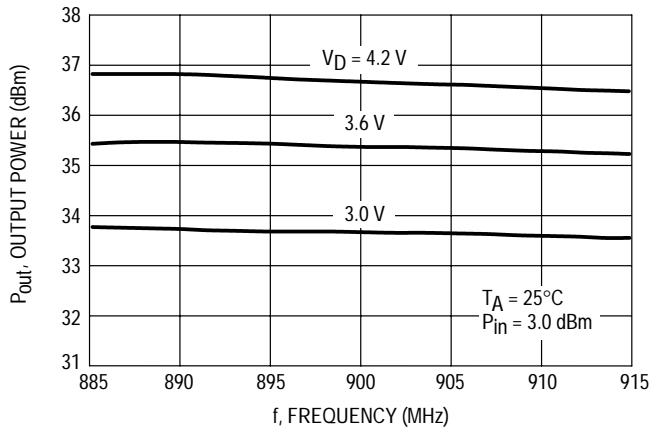

Figure 5. Power Added Efficiency versus Frequency

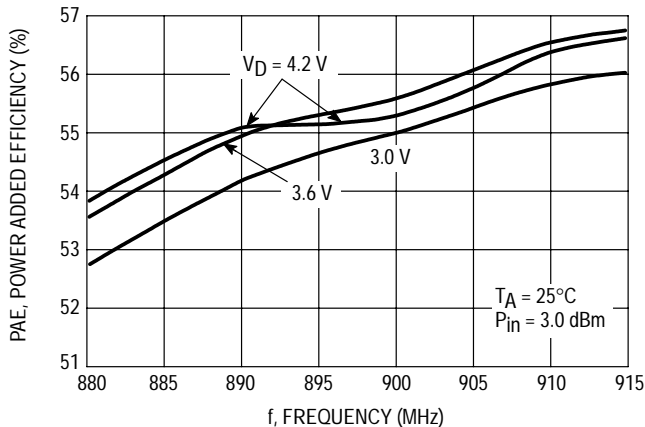

Figure 6. Output Power versus Frequency

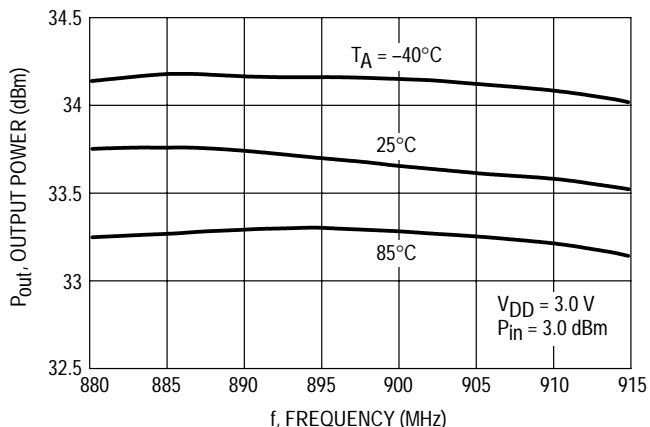

Figure 7. Output Power versus Frequency

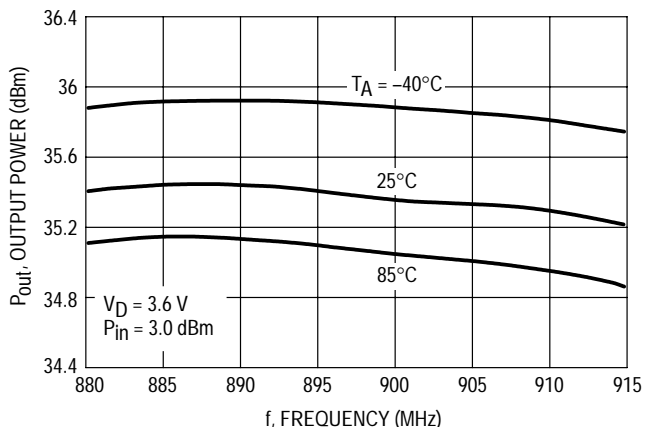

Figure 8. Output Power versus Frequency

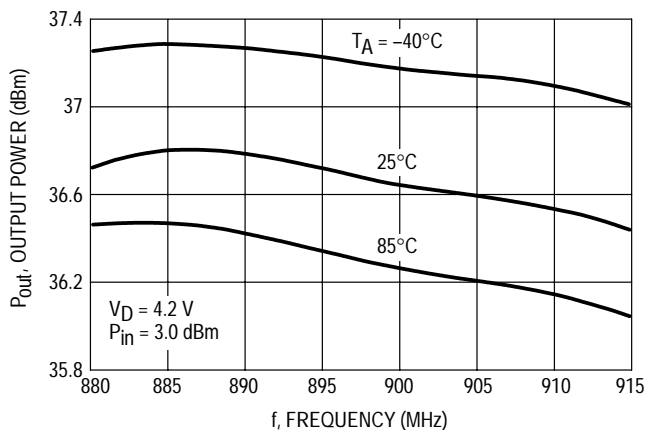
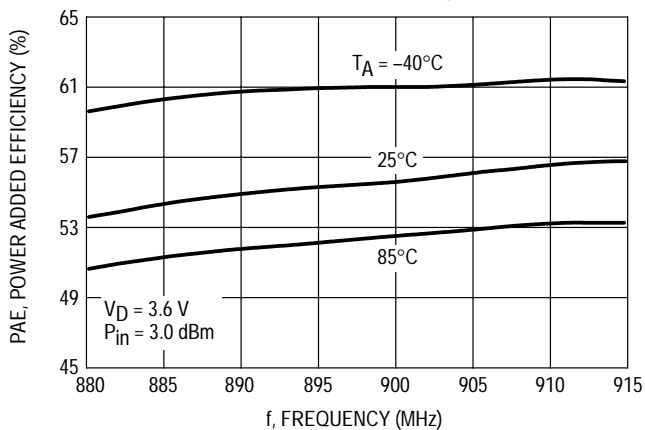

Figure 9. Power Added Efficiency versus Frequency



Freescale Semiconductor, Inc. DEVICE ON LIFETIME BUY

LAST SHIP 04JAN02 LAST ORDER 04JUL02

Figure 10. Output Power versus Drain Voltage

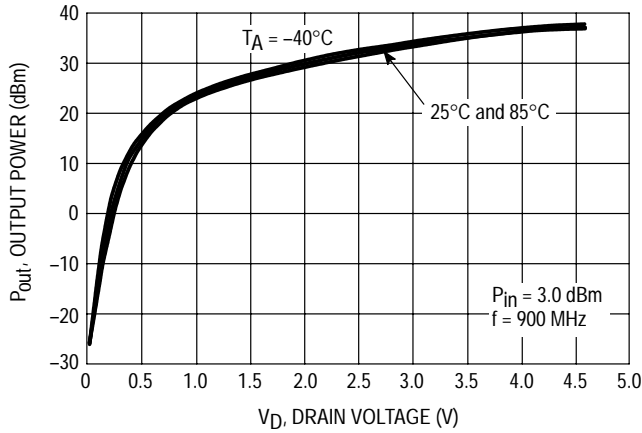

Figure 11. Power Added Efficiency versus Drain Voltage

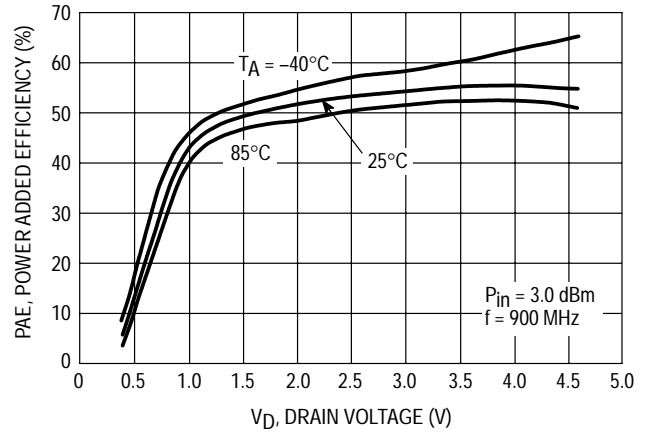

Figure 12. Positive Voltage Generator Output versus Drain Voltage

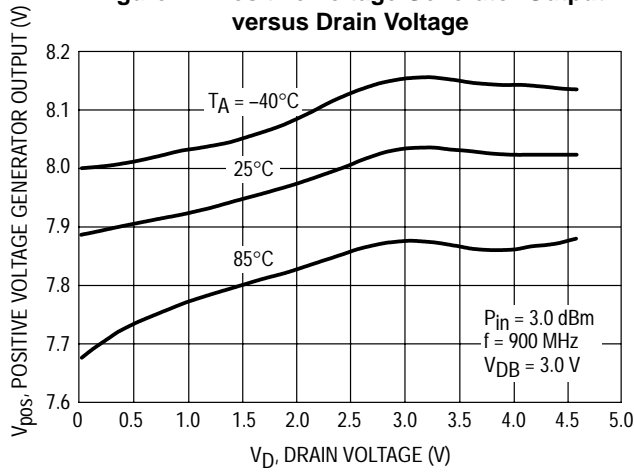

Figure 13. Positive Voltage Output versus Frequency

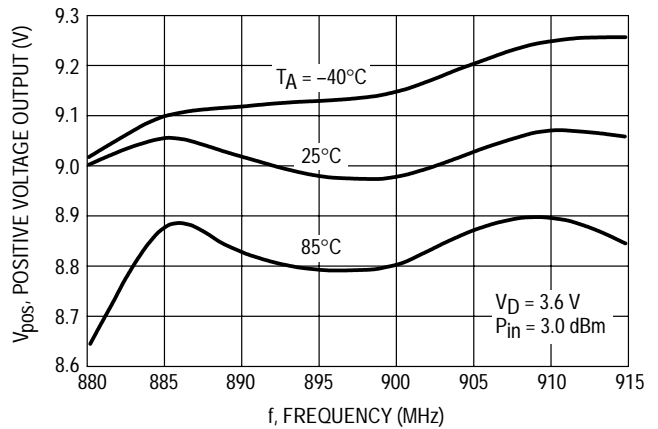

Figure 14. Second Harmonics versus Drain Voltage

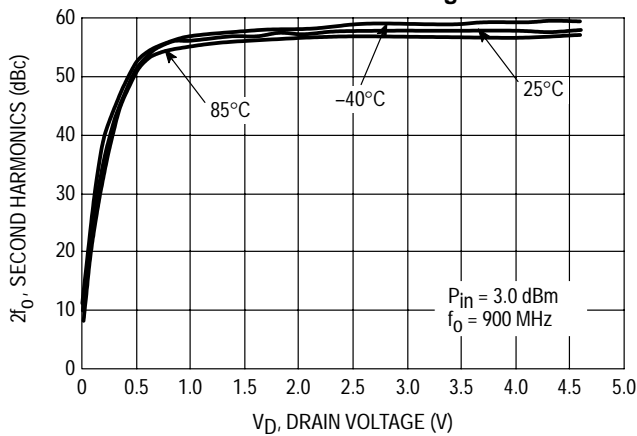
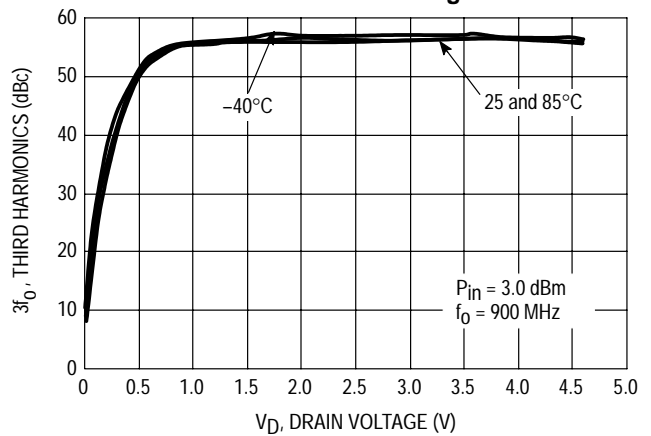

Figure 15. Third Harmonics versus Drain Voltage



Freescale Semiconductor, Inc. DEVICE ON LIFETIME BUY

LAST ORDER 04JUL02 LAST SHIP 04JAN02

Design Philosophy

The MRFIC0919 is a high performance three stage GaAs IPA (Integrated Power Amplifier) designed for GSM handheld radios (880 to 915 MHz frequency band). With a 3.6 V battery supply, it delivers typically 35.3 dBm of Output Power with 53% Power Added Efficiency.

It features an internal Negative Voltage Generator based on RF rectification of the input carrier after its amplification by a dedicated buffer stage (see Internal Block Diagram). This method eliminates spurs found on the Output signal when using DC/DC converter type negative voltage generators, either on or off chip. The buffer also generates a step-up positive voltage which can be used to drive a N-MOS drain switch.

The RF input power is split internally to the 3 stage RF line-up (Q1,Q2 and Q3) and the Buffer. This arrangement allows separate operation of Voltage Generation and Power Amplification for maximum flexibility.

External Circuit Considerations

The MRFIC0919 can be tuned by changing the values and/or positions of the appropriate external components (see Figure 1. Reference Circuit). While tuning the RF line-up, it is recommended to apply external negative supply in order to prevent any damage to the power amplifier stages. Poor tuning on the input may not provide enough RF power to operate the negative voltage generator properly.

Input matching is a shunt-C, series-L low-pass structure and should be optimized at the rated RF Input power (e.g., 3.0 dBm). Since the Input line feeds both 1st stage and buffer, Input matching should be iterated with Buffer and Q1 drain matching. Note that a DC blocking capacitor is included on chip.

Buffer drain is supplied and matched through a discrete chip inductor. Its value is tuned to get the maximum output from voltage generator.

The step-up positive voltage available at Pin 1 is both decoupled and maximized by a small shunt capacitor. This positive voltage which is approximately twice the buffer drain voltage can be used to drive a N-MOS drain switch for best performance.

Q1 drain is supplied and matched through a printed microstrip line that could be replaced by a discrete chip inductor as well. Its length (or equivalent inductor value) is tuned by sliding the RF decoupling capacitor along to get the maximum gain on the first stage. Make sure when laying out the PCB to put enough ground pads and vias close to the microstrip lines to help for this fine tuning.

Q2 is supplied through a printed microstrip line that contributes also to the interstage matching in order to provide optimum drive to the final stage. The line length is very small so replacing it with a discrete inductor is not practical.

Q3 drain is fed via a printed line that must handle the high supply current of that stage (2.0 to 3.0 Amp peak) without significant voltage drop. This line can be buried in an inner layer to save PCB space or be a discrete RF choke.

Output matching is accomplished with a two stage low-pass network. Easy implementation is achieved with shunt capacitors mounted along a 30 Ω microstrip transmission line. Value and position are chosen to reach a load line of 1.8 Ω while conjugating the device output parasitics. The network must also properly terminate the

second and third harmonic to optimize efficiency and reduce harmonic level. Use of high Q capacitor for the output matching circuit is recommended in order to get the best Output Power and Efficiency performance.

Biasing Considerations

The internally generated negative voltage is clamped by an external Zener diode in order to eliminate variation linked to Input power or Buffer supply. This negative voltage is used by three independent bias circuits to set the proper quiescent current of all stages. Each bias circuit is equivalent to a current source sinking its value from the bias pin. When the bias pins are grounded, nominal quiescent current and operating point of each RF stage are selected.

Q1 and Buffer share the Bias1 (0.25 mA) while Q2 and Q3 have dedicated Bias2 (0.25 mA) and Bias3 (0.5 mA) respectively. It is also possible to reference those bias pins to higher voltage than Gnd by using a series resistor that drops the equivalent voltage.

If those pins are left open, the corresponding stages are pinched-off. Thus the bias pins can be used as a means to select the MRFIC0919 or MRFIC1819 in a dual band configuration. The MRFIC1819 is the partner device to the MRFIC0919 and is designed for DCS1800/PCS1900 applications.

Table 2. Pin Function Description

Pin	Symbol	Description
1	V _p	Positive voltage output
2	V _{D3}	Third stage drain supply
3	RF Out	RF output
4	RF Out	RF output
5	RF Out	RF output
6	Bias3	Third stage bias
7	Bias2	Second stage bias
8	Bias1	Buffer and first stage bias
9	V _{SS}	Negative voltage output
10	V _{SC}	Negative voltage check
11	V _{D2}	Second stage drain supply
12	Gnd	Tied to ground externally
13	V _{D1}	First stage drain supply
14	RF In	RF input
15	Gnd	Tied to ground externally
16	V _{DB}	Buffer stage drain supply

V_{SC} is an open drain internal FET switch which is biased through the negative voltage. Consequently, this pin is high impedance when negative voltage is okay and low impedance (about 40 Ω) when negative voltage is missing.

Operation Procedure

The MRFIC0919 is a standard MESFET GaAs Power Amplifier, presence of a negative voltage to bias the RF line-up is essential in order to avoid any damage to the parts. Due to the fact that the negative voltage is generated through rectification of the RF input signal, a minimum input power

Freescale Semiconductor, Inc. DEVICE ON LIFETIME BUY

LAST ORDER 04JUL02 LAST SHIP 04JAN02

level is needed for correct operation of the demoboard. The following procedure will guaranty safe operation for doing the RF measurements.

Note: make sure that Bias1 (Pin 8) is connected to ground or will have equivalent potential for nominal biasing of Buffer stage.

1. Apply RF input power (RF In) >3.0 dBm.
2. Apply $V_{DB} = 3.0$ to 5.0 V.
3. Check that V_{SS} reaches approximately -5.1 V (settling of the negative voltage).
4. Apply $V_{D1,2\&3} = 3.0$ to 5.5 V.
5. Measure RF output power and relevant parameters.

Proceed in the reverse order to switch off the Power Amplifier.

For linear operation, an external negative voltage will have to be supplied to the V_{SS} pin to maintain initial quiescent operating conditions of the FET amplifiers since the RF input will not provide sufficient voltage to operate the negative voltage generator. When using an external negative voltage supply, supply voltage to V_{DB} (Pin 16) would no longer be required.

Control Considerations

MRFIC0919 application uses the drain control technique developed for our previous range of GaAs IPAs (refer to application note AN1599). This method relies on the fact that for an RF amplifier operating in saturation mode, the RF output power is proportional to the square of the Amplifier drain voltage: $P_{out}(\text{Watt})=k \cdot V_D(\text{Volt}) \cdot V_D(\text{Volt})$.

In the proposed application circuit (see Figure 2), a PMOS FET is used to switch the IPA drain and vary the drain supply voltage from 0 to battery voltage. As the PMOS FET has a non linear behavior, an OpAmp is included in the application. This OpAmp is linearizing the PMOS by sensing its drain output and gives a true linear relationship between the Control voltage and the RF output voltage.

The obtained power control transfer function is so linear and repeatable than it can be used to predict the output power within a dynamic range of 25 to 30 dB over frequency and temperature. This so called "open-loop" arrangement eliminates the need for coupler and detector required for the classical but complex closed-loop control and consequently reduces the Insertion Loss from Power Amplifier to the Antenna.

The block diagram (Figure 16) shows the principle of operation as implemented in the application circuit of Figure 2. The OpAmp is connected as an inverter to compensate the negative gain of the PMOS switch.

Figure 16. Drain Control through PMOS Switch

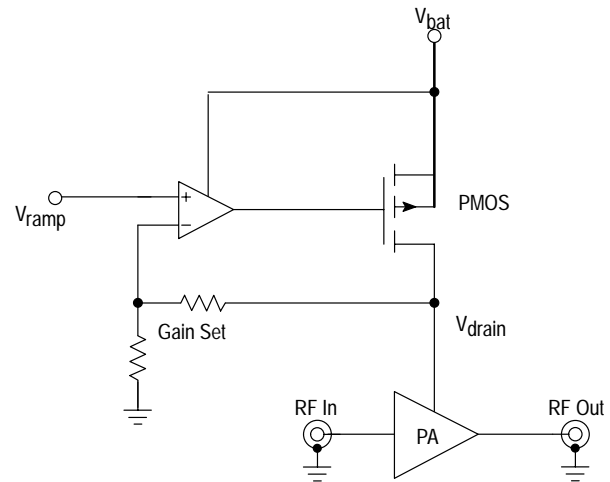

NOTE: The positive voltage generated by the Buffer stage can be used to supply the OpAmp and make it possible to drive a NMOS switch as a voltage follower. Doing so, the main advantage is to have a lower R_{dson} switch and better intrinsic linearity.

The following plot illustrates the "open-loop" performance as far as temperature stability. The measured datas are displayed in a log-scale in order to have a good representation of both the dynamic and the linearity of control. The variation of P_{out} accross the frequency band are also very small (less than 1.0 dB ripple) and are kept to that small amount when controlling P_{out} through the Drain voltage.

Figure 17. P_{out} versus V_D

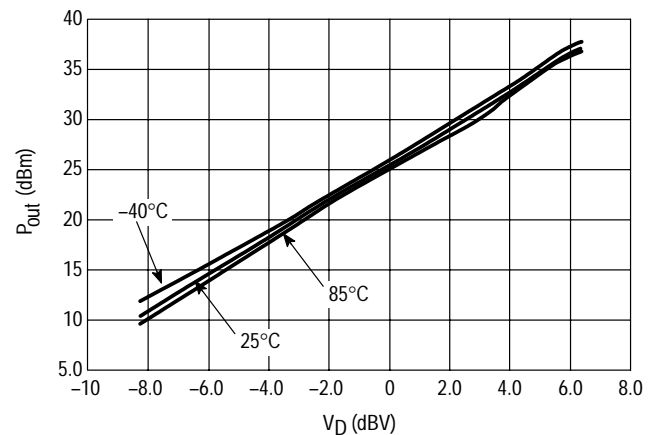

Freescale Semiconductor, Inc. DEVICE ON LIFETIME BUY

LAST ORDER 04JUL02 LAST SHIP 04JAN02

Figure 18. Timing Guide

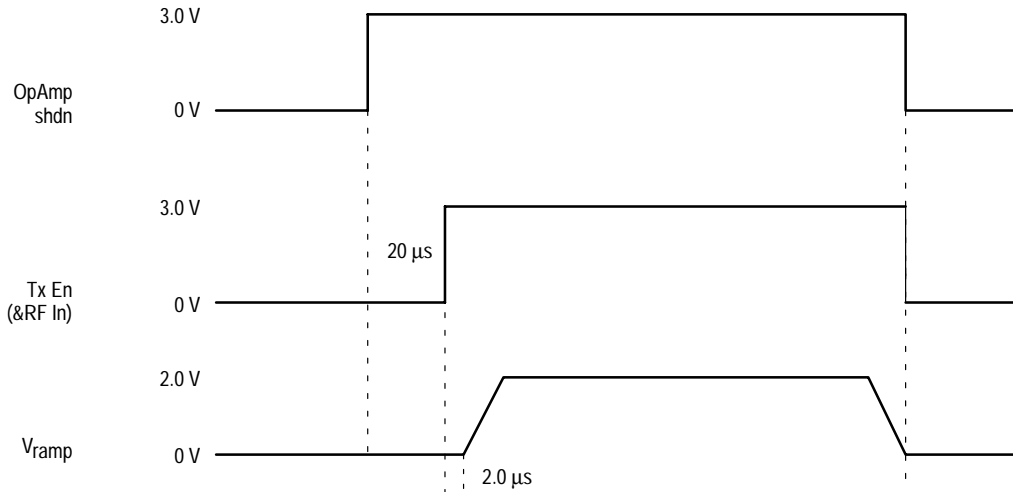

Burst mode

Use Figure 18 as a guide line to perform burst mode measurements with the complete application circuit of Figure 2. Notice that the V_{SC} pin is connected to V_{ramp} (through a resistor) and act as a pull down when negative voltage is missing so that drain voltage is not applied to the RF line-up.

– Bursting the OpAmp with its Pin 8 (shdn) is not mandatory during a call as the OpAmp current consumption is very small (1.0 to 2.0 mA). This pin is mainly used for the idle mode of the radio. In any case, the wake-up time of the OpAmp is very short.

– V_{ramp} can be applied soon after Tx EN since the internal negative voltage generator settles in less than 2.0 μs.

– Tx EN signal can be used to switch the input power (using a driver or attenuator) in order to provide higher isolation for on/off burst dynamic.

References (Motorola application notes)

AN1599 – Power Control with the MRFIC0913 GaAs Integrated Power Amplifier and MC33169 Support IC.

AN1602 – 3.6 V and 4.8 V GSM/DCS1800 Dual Band PA Application with DECT capability Using Standard Motorola RFIC's.

OUTLINE DIMENSIONS

PLASTIC PACKAGE
CASE 948L-01
(TSSOP-16EP)
ISSUE O

- NOTES:
- 1 DIMENSIONS ARE IN MILLIMETERS.
 - 2 INTERPRET DIMENSIONS AND TOLERANCES PER ASME Y14.5M, 1994.
 - 3 DIMENSION D DOES NOT INCLUDE MOLD FLASH, PROTRUSIONS OR GATE BURRS. MOLD FLASH OR GATE BURRS SHALL NOT EXCEED 0.15 PER SIDE.
 - 4 DIMENSION E1 DOES NOT INCLUDE INTERLEAD FLASH OR PROTRUSION. INTERLEAD FLASH OR PROTRUSION SHALL NOT EXCEED 0.25 PER SIDE.
 - 5 DIMENSION b DOES NOT INCLUDE DAMBAR PROTRUSION. ALLOWABLE DAMBAR PROTRUSION SHALL BE 0.08 TOTAL IN EXCESS OF THE b DIMENSION AT MAXIMUM MATERIAL CONDITION.
 - 6 TERMINAL NUMBERS ARE SHOWN FOR REFERENCE ONLY.
 - 7 DIMENSIONS D AND E1 ARE TO BE DETERMINED AT DATUM PLANE H.

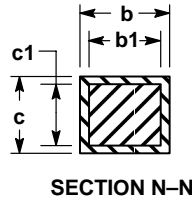
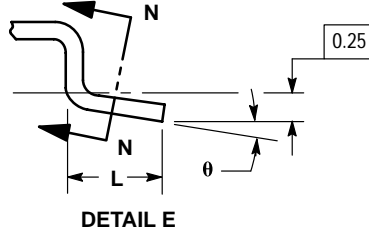
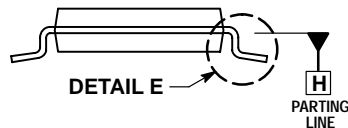
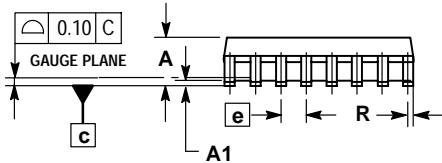
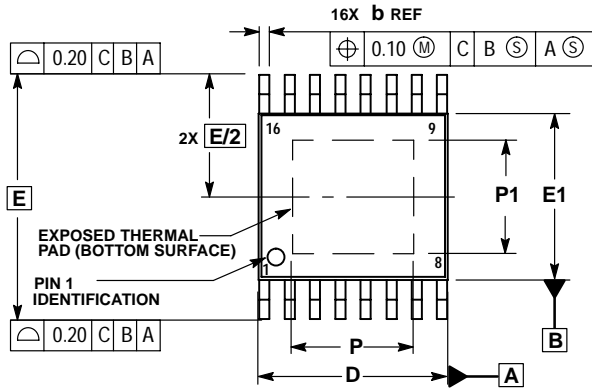

DIM	MILLIMETERS	
	MIN	MAX
A	---	1.20
A1	0.00	0.10
b	0.19	0.30
b1	0.19	0.25
c	0.09	0.20
c1	0.09	0.16
D	4.90	5.10
E	6.40 BSC	
E1	4.30	4.50
e	0.65 BSC	
L	0.50	0.75
P	---	3.90
P1	---	3.00
R	0.18	0.28
θ	0°	8°

Freescale Semiconductor, Inc. DEVICE ON LIFETIME BUY

LAST ORDER 04JUL02 LAST SHIP 04JAN02

Freescale Semiconductor, Inc.
DEVICE ON LIFETIME BUY

LAST ORDER 04JUL02 LAST SHIP 04JAN02

Motorola reserves the right to make changes without further notice to any products herein. Motorola makes no warranty, representation or guarantee regarding the suitability of its products for any particular purpose, nor does Motorola assume any liability arising out of the application or use of any product or circuit, and specifically disclaims any and all liability, including without limitation consequential or incidental damages. "Typical" parameters which may be provided in Motorola data sheets and/or specifications can and do vary in different applications and actual performance may vary over time. All operating parameters, including "Typicals" must be validated for each customer application by customer's technical experts. Motorola does not convey any license under its patent rights nor the rights of others. Motorola products are not designed, intended, or authorized for use as components in systems intended for surgical implant into the body, or other applications intended to support or sustain life, or for any other application in which the failure of the Motorola product could create a situation where personal injury or death may occur. Should Buyer purchase or use Motorola products for any such unintended or unauthorized application, Buyer shall indemnify and hold Motorola and its officers, employees, subsidiaries, affiliates, and distributors harmless against all claims, costs, damages, and expenses, and reasonable attorney fees arising out of, directly or indirectly, any claim of personal injury or death associated with such unintended or unauthorized use, even if such claim alleges that Motorola was negligent regarding the design or manufacture of the part. Motorola and  are registered trademarks of Motorola, Inc. Motorola, Inc. is an Equal Opportunity/Affirmative Action Employer.

How to reach us:

USA/EUROPE/Locations Not Listed: Motorola Literature Distribution;
P.O. Box 5405, Denver, Colorado 80217. 1-303-675-2140 or 1-800-441-2447

JAPAN: Motorola Japan Ltd.; SPS, Technical Information Center, 3-20-1,
Minami-Azabu, Minato-ku, Tokyo 106-8573 Japan. 81-3-3440-3569

Technical Information Center: 1-800-521-6274

ASIA/PACIFIC: Motorola Semiconductors H.K. Ltd.; Silicon Harbour Centre,
2, Dai King Street, Tai Po Industrial Estate, Tai Po, N.T., Hong Kong.
852-26668334

HOME PAGE: <http://www.motorola.com/semiconductors/>



MOTOROLA



**For More Information On This Product,
Go to: www.freescale.com**

MRFIC0919/D