

### FEATURES

- CLASS A OPERATION
- HIGH POWER ADDED EFFICIENCY
- EMPLOYS P.H.S. (PLATED HEAT SINK) AND VIA HOLE GROUNDING
- BROAD BANDWIDTH
- INPUT OF PACKAGED DEVICE PARTIALLY MATCHED TO 50 Ω
- AVAILABILITY:  
Hermetic Package  
Chip

### DESCRIPTION

The NE9004 is a 0.5 micron recessed gate GaAs power FET for commercial and space amplifier and oscillator applications to 20 GHz. This device is part of the NE900 series of Ku-Band power transistors which includes the NE9000, NE9001 and NE9002.

The NE9004 is a four cell die of 3000 μm total gate width incorporating wrap-around source metallization and via hole source grounding for superior RF and thermal performance. The device is available in chip form and in a hermetic ceramic package. The series is space qualified.

NE900474-13, -15  
OUTPUT POWER AND POWER ADDED EFFICIENCY vs. INPUT POWER

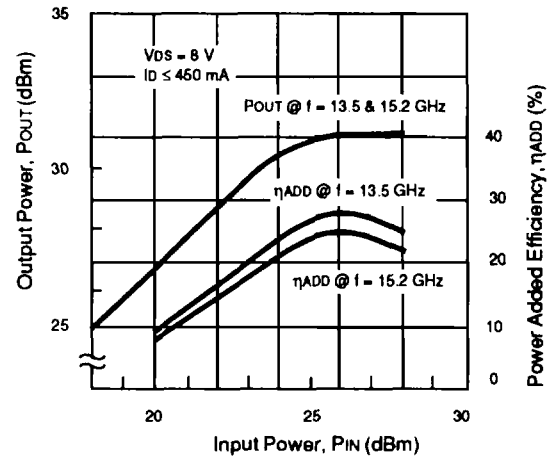

### ELECTRICAL CHARACTERISTICS (T<sub>A</sub> = 25°C)

PARTNUMBER			NE900400G NE900474-13 00 (CHIP), 74			NE900474-15 74		
PACKAGE OUTLINE								
SYMBOLS	PARAMETERS AND CONDITIONS	UNITS	MIN	TYP	MAX	MIN	TYP	MAX
P <sub>TEST</sub>	Output Power at Test Point P <sub>IN</sub> = 25.0 dBm, V <sub>DS</sub> = 8 V, I <sub>D</sub> = 450 mA, f = 13.5 GHz P <sub>IN</sub> = 25.5 dBm, V <sub>DS</sub> = 8 V, I <sub>D</sub> = 450 mA, f = 15.2 GHz	dBm dBm	30.5	31		30.5	31	
P <sub>1dB</sub>	Output Power at 1 dB Compression Point V <sub>DS</sub> = 8 V, I <sub>D</sub> = 450 mA, f = 13.5 GHz V <sub>DS</sub> = 8 V, I <sub>D</sub> = 450 mA, f = 15.2 GHz	dBm dBm		31			31	
G <sub>1dB</sub>	Gain at 1 dB Compression Point V <sub>DS</sub> = 8 V, I <sub>D</sub> = 450 mA, f = 13.5 GHz V <sub>DS</sub> = 8 V, I <sub>D</sub> = 450 mA, f = 15.2 GHz	dB dB		6 6			6 6	
η <sub>ADD</sub> <sup>1</sup>	Power Added Efficiency V <sub>DS</sub> = 8 V, I <sub>D</sub> = 450 mA, f = 13.5 GHz V <sub>DS</sub> = 8 V, I <sub>D</sub> = 450 mA, f = 15.2 GHz	% %		26 24			26 24	
I <sub>DSS</sub>	Saturated Drain Current at V <sub>DS</sub> = 2.5 V, V <sub>GS</sub> = 0	mA	600	900	1200	600	900	1200
V <sub>P</sub>	Pinch-off Voltage at V <sub>DS</sub> = 2.5 V, I <sub>DS</sub> = 20 mA		-2	-3.5	-5	-2	-3.5	-5
g <sub>m</sub>	Transconductance at V <sub>DS</sub> = 2.5 V, I <sub>DS</sub> = 300 mA	mS		200			200	
R <sub>TH</sub>	Thermal Resistance (Channel-to-Case)	°C/W			20			20
P <sub>T</sub>	Total Power Dissipation (T <sub>CASE</sub> = 50°C)	W			7.5			7.5

Note:  
1.  $\eta_{ADD} = \frac{P_{OUT} - P_{IN}}{V_{DS} \times I_D} \times 100\%$

**ABSOLUTE MAXIMUM RATINGS** (TA = 25°C)

SYMBOLS	PARAMETERS	UNITS	RATINGS
V <sub>DS</sub>	Drain to Source Voltage	V	20
V <sub>GS</sub>	Gate to Source Voltage	V	-9
I <sub>DS</sub>	Drain Current	mA	1200
I <sub>G</sub>	Gate Current	mA	10

**SELECTION CHART**

PART NUMBER	TYPICAL PERFORMANCE		
	P <sub>1dB</sub> (WATTS)	FREQUENCY RANGE (GHz)	G <sub>1dB</sub> (dB)
NE900400G1	1.25	up to 20	6
NE900474-13	1.25	9 to 13.5	6
NE900474-15	1.25	13 to 15.2	6

**TYPICAL COMMON SOURCE SCATTERING PARAMETERS**

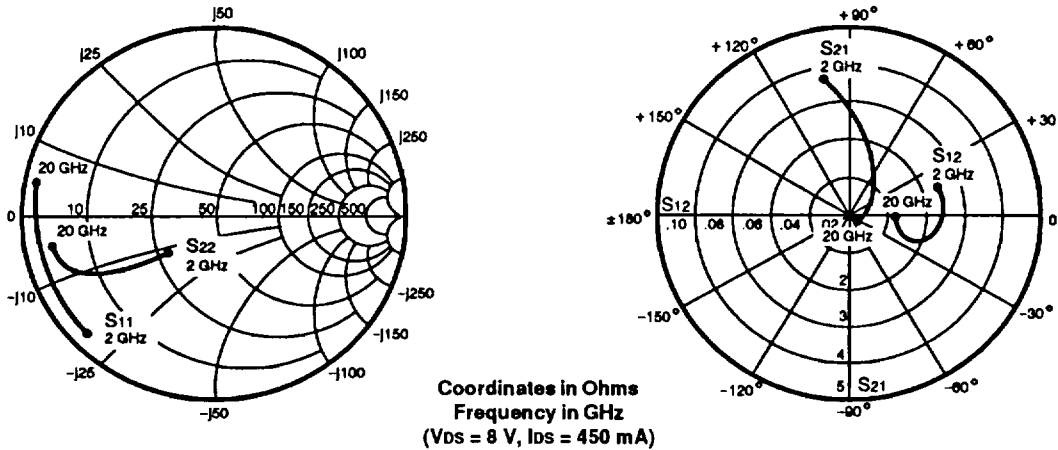

**Note:** S-Parameters include bond wires.  
 Gate: Total 4 wire (s), 1 per bond pad, 0.0134" (340 μm) long each wire.  
 Drain: Total 4 wire (s), 1 per bond pad, 0.0104" (264 μm) long each wire.  
 Source: No bond wires. Gold plated wrap-around to back side of chip.  
 Wire: 0.0007" (17.8 μm) diameter, gold.

**NE900400G**

V<sub>DS</sub> = 8 V, I<sub>D</sub> = 450 mA

FREQUENCY  
(MHz)

FREQ (MHz)	S <sub>11</sub>		S <sub>21</sub>		S <sub>12</sub>		S <sub>22</sub>		K	MAG <sup>1</sup> (dB)
	MAG	ANG	MAG	ANG	MAG	ANG	MAG	ANG		
2000	0.92	-138	3.56	97	0.051	16	0.36	-146	0.180	18
3000	0.92	-151	2.47	81	0.050	7	0.39	-148	0.254	17
4000	0.92	-159	1.85	69	0.050	1	0.44	-148	0.328	16
5000	0.92	-164	1.46	60	0.049	-4	0.48	-149	0.403	15
6000	0.92	-168	1.21	52	0.050	-4	0.53	-149	0.444	14
7000	0.92	-171	1.03	45	0.047	-12	0.57	-151	0.552	13
8000	0.92	-172	0.90	37	0.045	-13	0.61	-152	0.622	13
9000	0.92	-174	0.78	29	0.041	-16	0.65	-153	0.763	13
10000	0.93	-176	0.69	23	0.040	-17	0.69	-154	0.765	12
11000	0.93	-179	0.62	16	0.038	-21	0.72	-155	0.844	12
12000	0.93	179	0.56	8	0.036	-22	0.75	-156	1.040	11
13000	0.93	178	0.49	3	0.032	-23	0.77	-157	1.239	9
14000	0.93	176	0.46	-2	0.030	-25	0.79	-158	1.451	8
15000	0.93	174	0.43	-7	0.028	-23	0.81	-159	1.577	7
16000	0.93	173	0.39	-12	0.027	-21	0.82	-161	1.659	7
17000	0.93	172	0.37	-16	0.025	-19	0.83	-162	1.888	6
18000	0.93	172	0.35	-20	0.024	-17	0.83	-164	2.066	6
19000	0.93	171	0.32	-26	0.024	-5	0.84	-166	1.960	6
20000	0.93	171	0.30	-29	0.025	-0	0.85	-169	1.839	6

Note:

1. Gain Calculations:

$$MAG = \frac{|S_{21}|}{|S_{12}|} \left( K \pm \sqrt{K^2 - 1} \right). \text{ When } K \leq 1, \text{ MAG is undefined and MSG values are used. } MSG = \frac{|S_{21}|}{|S_{12}|}, K = \frac{1 + |\Delta|^2 - |S_{11}|^2 - |S_{22}|^2}{2 |S_{12} S_{21}|}, \Delta = S_{11} S_{22} - S_{21} S_{12}$$

MAG = Maximum Available Gain

MSG = Maximum Stable Gain



# NE9004 SERIES

## TYPICAL SCATTERING PARAMETERS (T<sub>A</sub> = 25°C)

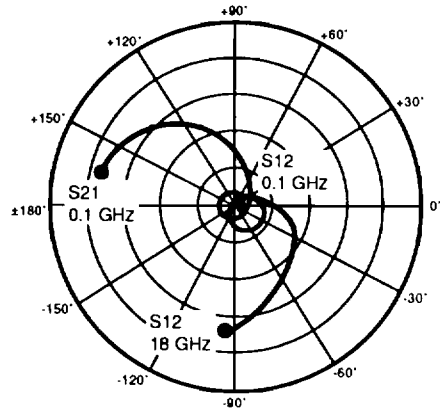
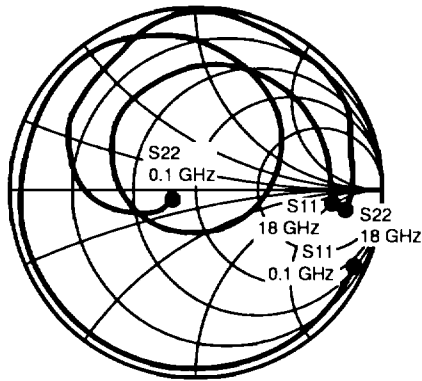

### NE900474-13

V<sub>ds</sub> = 8 V, I<sub>D</sub> = 450 mA

FREQUENCY (GHz)	S <sub>11</sub>		S <sub>21</sub>		S <sub>12</sub>		S <sub>22</sub>		K (dB)	MAG <sup>1</sup>
	MAG	ANG	MAG	ANG	MAG	ANG	MAG	ANG		
0.1	0.998	-24.000	11.204	165.800	0.006	99.500	0.104	-150.800	0.045	32.712
0.2	0.989	-46.400	10.546	152.900	0.012	69.700	0.147	-143.900	0.060	29.439
0.5	0.956	-95.700	7.826	123.700	0.024	42.800	0.240	-147.300	0.161	25.133
1.0	0.933	-136.600	4.870	96.700	0.029	24.200	0.305	-154.800	0.312	22.251
2.0	0.925	-170.400	2.648	66.600	0.030	6.300	0.382	-161.100	0.563	19.458
3.0	0.912	171.800	1.787	44.700	0.025	3.400	0.453	-166.900	1.218	15.725
4.0	0.892	159.200	1.355	26.800	0.024	12.100	0.519	-173.700	2.036	11.709
5.0	0.905	149.200	1.145	10.400	0.030	18.400	0.581	178.900	1.505	11.618
6.0	0.916	138.200	1.024	-6.000	0.035	17.900	0.642	169.800	1.079	12.946
7.0	0.908	126.500	0.968	-22.500	0.042	16.500	0.697	161.100	0.877	13.626
8.0	0.882	113.200	0.968	-39.600	0.050	6.400	0.739	152.300	0.752	12.869
9.0	0.826	95.500	1.017	-60.000	0.060	-4.700	0.759	142.600	0.795	12.292
9.5	0.789	84.900	1.059	-71.400	0.065	-11.900	0.768	136.900	0.811	12.120
10.0	0.745	72.200	1.119	-83.900	0.067	-23.700	0.782	130.500	0.814	12.228
10.5	0.689	57.600	1.186	-97.700	0.070	-34.200	0.800	123.600	0.804	12.290
11.0	0.614	39.200	1.262	-113.600	0.068	-47.900	0.831	116.700	0.791	12.686
11.5	0.505	16.000	1.331	-132.000	0.063	-65.000	0.873	109.200	0.750	13.248
12.0	0.367	-14.800	1.361	-152.000	0.051	-83.500	0.912	101.600	0.819	14.263
12.5	0.255	-64.100	1.341	-173.300	0.034	-104.400	0.945	93.300	0.975	15.959
13.0	0.258	-128.100	1.263	165.600	0.015	-136.100	0.960	84.100	1.871	13.873
13.5	0.352	-172.300	1.151	145.200	0.009	53.200	0.955	74.500	3.577	12.610
14.0	0.447	160.700	1.044	126.300	0.027	35.500	0.950	63.800	1.203	13.149
15.0	0.582	118.800	0.879	88.000	0.064	5.000	0.961	40.300	0.251	11.378
16.0	0.678	82.100	0.779	44.900	0.137	-21.600	0.905	17.400	0.365	7.548
17.0	0.749	39.400	0.625	3.400	0.193	-60.500	0.888	6.200	0.591	5.103
18.0	0.769	-6.000	0.568	-40.900	0.274	-93.100	0.846	-7.800	0.778	3.166

TYPICAL SCATTERING PARAMETERS (TA = 25°C)

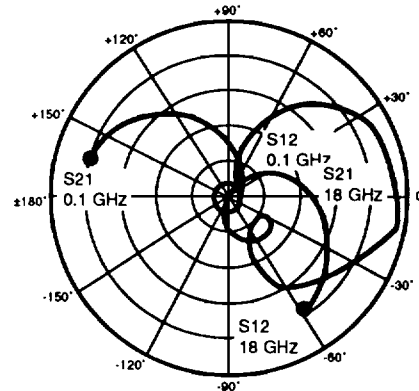
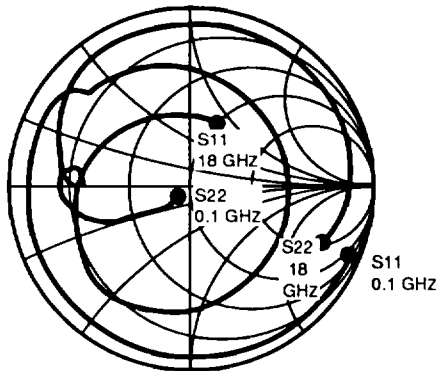

NE900474-15

Vds = 8 V, ID = 450 mA

FREQUENCY (GHz)	S11		S21		S12		S22		K	MAG <sup>1</sup> (dB)
	MAG	ANG	MAG	ANG	MAG	ANG	MAG	ANG		
0.1	0.992	-23.500	12.212	165.600	0.006	91.300	0.075	-123.700	0.091	33.086
0.2	0.981	-45.800	11.469	152.700	0.013	68.700	0.125	-126.000	0.096	29.456
0.5	0.932	-94.100	8.438	123.800	0.024	45.200	0.228	-136.900	0.246	25.460
1.0	0.897	-133.300	5.203	97.800	0.030	34.700	0.297	-145.700	0.483	22.391
2.0	0.882	-163.200	2.817	70.000	0.030	38.400	0.385	-149.600	0.998	19.727
3.0	0.874	-178.400	1.908	50.300	0.036	55.900	0.471	-153.900	1.290	14.012
4.0	0.861	171.300	1.456	34.700	0.053	71.400	0.543	-159.300	1.254	11.356
5.0	0.862	162.900	1.225	21.700	0.099	74.600	0.609	-164.700	0.801	10.925
6.0	0.868	152.600	1.109	9.100	0.181	65.500	0.676	-173.200	0.487	7.873
7.0	0.805	138.700	1.073	-2.700	0.360	29.200	0.690	174.400	0.273	4.743
8.0	0.734	129.600	1.113	-17.100	0.315	-27.400	0.592	171.200	0.182	5.482
9.0	0.694	112.500	1.203	-36.600	0.128	-66.400	0.621	-179.700	0.762	9.731
9.5	0.663	97.800	1.249	-47.000	0.087	-50.400	0.658	177.600	1.091	9.730
10.0	0.624	79.900	1.303	-58.500	0.084	-34.300	0.682	173.600	0.975	11.363
11.0	0.571	32.300	1.397	-85.800	0.113	-30.300	0.729	163.000	0.804	10.921
11.5	0.568	4.000	1.417	-101.700	0.122	-38.500	0.764	156.300	0.682	10.650
12.0	0.580	-23.600	1.399	-117.900	0.122	-49.300	0.802	148.700	0.602	10.595
12.5	0.612	-49.200	1.362	-134.300	0.117	-60.500	0.838	140.500	0.522	10.660
13.0	0.647	-71.700	1.302	-150.200	0.100	-73.600	0.862	130.800	0.514	11.146
13.5	0.683	-90.800	1.245	-166.400	0.079	-86.200	0.873	119.700	0.575	11.975
14.0	0.712	-107.500	1.202	177.000	0.050	-100.900	0.879	105.900	0.829	13.809
14.5	0.730	-122.400	1.159	159.600	0.020	-120.500	0.880	89.300	2.088	11.696
15.0	0.721	-136.600	1.136	140.400	0.018	61.300	0.896	70.200	2.347	11.498
16.0	0.623	-163.000	1.073	100.800	0.104	30.500	0.940	30.500	0.438	10.136
17.0	0.485	148.000	0.982	51.500	0.219	-12.300	0.910	-0.400	0.552	6.517
18.0	0.385	59.200	0.814	-1.600	0.310	-55.100	0.813	-25.000	0.703	4.193

# NE9004 SERIES

## CHIP DIMENSIONS AND HANDLING

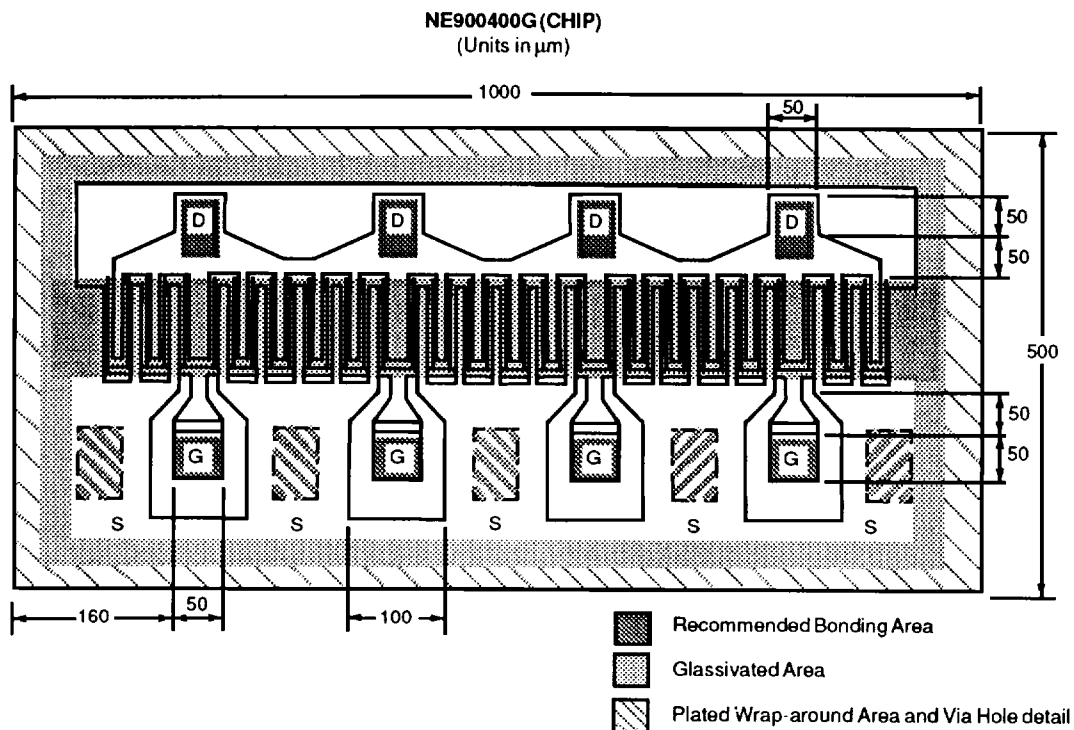

### DIE ATTACHMENT

Die attach can be accomplished with a Au-Ge ( $390 \pm 10^\circ\text{C}$ ) preform in a forming gas environment. Epoxy die attach is not recommended.

### BONDING

Gate and drain bonding should be minimum length, semi-hard gold wire (3-8% elongation) 30 microns or less in diameter.

Bonding should be performed with a wedge tip that has a taper of approximately  $15^\circ$ . Die attach and bonding time should be kept to a minimum. As a general rule, the bonding operation should be kept within a  $300^\circ\text{C}$  to 10 minute curve. If longer periods are required, the temperature should be lowered.

### PRECAUTIONS

The user must operate in a clean, dry environment. The chip channel is glassivated for mechanical protection only and does not preclude the necessity of a clean environment.

The bonding equipment should be periodically checked for sources of surge voltage and should be properly grounded at all times. All test and handling equipment should be grounded to minimize the possibilities of static discharge.

See AN-1001 (Recommended Handling Procedures for microwave transistor & MMIC chips) for additional information.

## TYPICAL PERFORMANCE CURVES

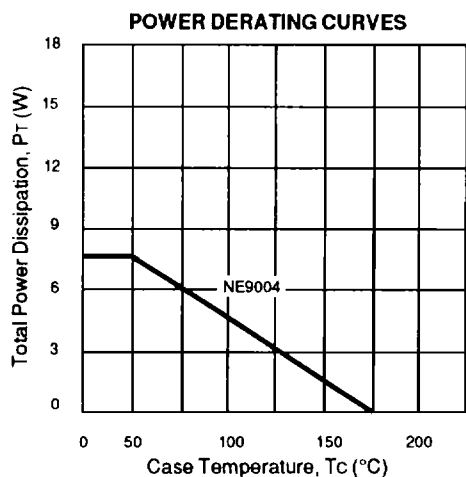

## OUTLINE DIMENSIONS

### PACKAGE OUTLINE 74

(Units in mm)

