

## Features

- One piece construction
- TIA/EIA 604 compliant
- Field installable
- Compatible with standard hand and machine polishing equipment
- 900um and 2.0 to 3.0mm cable compatible
- Designed for easy fiber threading
- Materials:
  - Nut: Nickel-plated Brass
  - Stem: Nickel-plated Brass
  - Ferrule: Zirconia



## Specifications

- Insertion Loss: 0.15dB typical for Single-Mode
- Return Loss: <-45dB typical for PC polish
- Operating Temp: -40° to 85° C
- Durability: >1000 cycles
- Cable Retention: >25Lb, straight pull

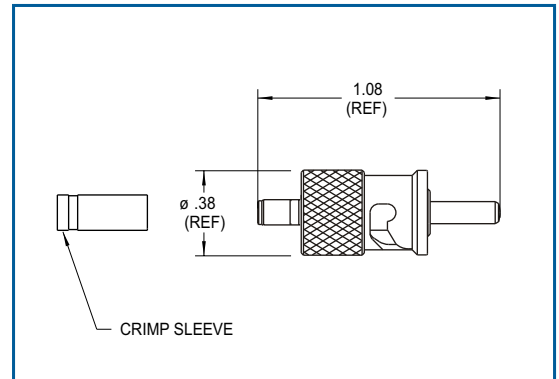

## Part Numbers

Description	Application	ID <sup>1</sup>	P/N	Boot <sup>2</sup>
ST® External Crimp	SM	126	2565-1	Blue, 3mm
ST® External Crimp	MM	127	2565-2	Black, 3mm
ST® External Crimp	MM	144	2565-3	Black, 3mm
ST® External Crimp	MM	173.5	2565-4	Black, 3mm
ST® External Crimp	MM	142	2565-14	Black, 3mm
ST® External Crimp	MM	231	2565-28	Black, 3mm

<sup>1</sup> Other ID's available, contact factory

<sup>2</sup> Boots listed are shipped with the connector unless otherwise specified at time of order. Contact factory for other colors and sizes.

## Related Products

ST® Adapters	2523 series
ST®, Ruggedized Connectors	2566 series
Crimp Tool	2560-2
BELLCORE Strain Relief Boot Kit	2579 series

Data contained on this specification sheet is believed to be accurate as of the publication date. Johanson reserves the right to make changes deemed appropriate. Consult the factory for current engineering drawings and data.