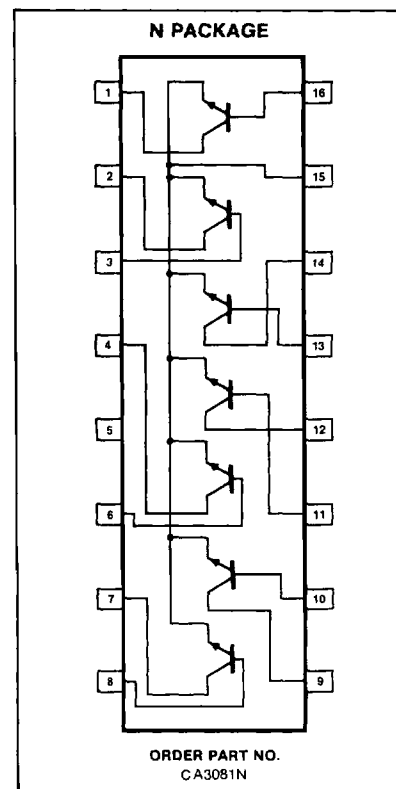
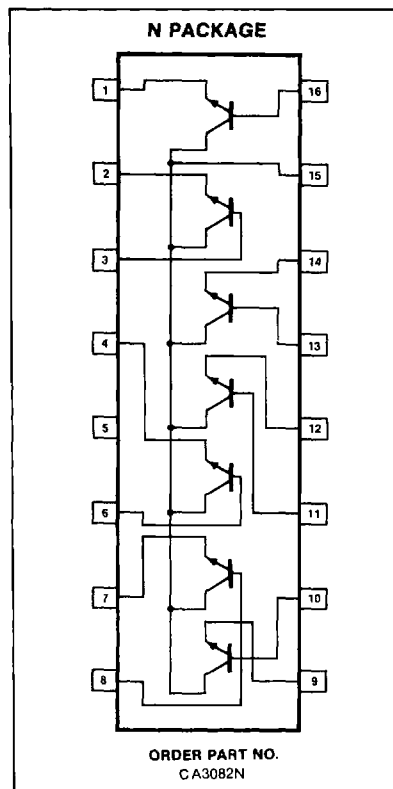

**DESCRIPTION**

The CA3081 and CA3082 are monolithic integrated circuits each consisting of seven separate npn transistors on a common substrate. The transistors are capable of driving loads up to 100mA. At the same time the transistor geometry used gives maximum current gain at quite low currents, making the devices also suitable for small signal applications. In the CA3081 the transistors are connected in common emitter configuration while in the CA3082 the collectors are common. The transistor arrays are particularly suitable for driving light-emitting diodes and seven-segment displays as well as for general purpose applications.

**FEATURES**

- $V_{CBO}$ -50V
- $V_{CEO}$ -35V
- Collector current 100mA
- Common emitter or common collector configuration

**PIN CONFIGURATIONS****ABSOLUTE MAXIMUM RATINGS**

PARAMETER	RATING	UNIT
$V_{CEO}$ Collector-emitter voltage (open base)	35	V
$V_{CBO}$ Collector-base voltage (open emitter)	50	V
$V_{CSO}$ Collector-substrate voltage (open base and emitter)	50	V
$V_{EBO}$ Emitter-base voltage (open collector)	6	V
$I_C$ Collector current (dc)	100	mA
$I_B$ Base current (dc)	20	mA
$P$ Power dissipation: any one transistor	500	mW
$P_{TOT}$ total package (see derating curve)	750	mW
$T_A$ Operating ambient temperature	-40 to +125	°C
$T_{stg}$ Storage temperature	-50 to +125	°C
$T_j$ Junction temperature	125	°C
Lead temperature (10sec)	300	°C

**DC ELECTRICAL CHARACTERISTICS**  $T_A = 25^\circ\text{C}$  unless otherwise specified.

PARAMETER	TEST CONDITIONS	CA3081/3082			UNIT
		Min	Typ	Max	
$V_{CEO}$ Collector-emitter breakdown voltage	$I_C = 1\text{mA}, I_B = 0$	35			V
$V_{CSO}$ Collector-substrate breakdown voltage	$I_C = 1\text{mA}, I_B = 0, I_E = 0$	50			V
$V_{CBO}$ Collector-base breakdown voltage	$I_C = 10\mu\text{A}, I_E = 0$	50			V
$V_{EBO}$ Emitter-base breakdown voltage	$I_E = 10\mu\text{A}, I_C = 0$	6.5	7.0	7.5	V
$h_{fe}$ DC current gain	$I_E = 10\mu\text{A}, V_{CE} = 5\text{V}$ $I_E = 1\text{mA}, V_{CE} = 5\text{V}$ $I_E = 20\text{mA}, V_{CE} = 5\text{V}$	50 50 30		300 300 200	
$V_{SAT}$ Saturation voltage	$I_C = 5\text{mA}, I_B = .5\text{mA}$ $I_C = 50\text{mA}, I_B = 5\text{mA}$		0.2 0.4	0.4 0.8	V V

## NOTE

As each collector forms a parasitic diode with the substrate, the substrate has to be connected to a voltage which is lower than the lowest collector voltage

To avoid parasitic coupling between the transistors, the substrate (pin 5) should be connected to signal ground.

**TYPICAL PERFORMANCE CHARACTERISTICS**