

Features

- DC–6 GHz Operation
- 15 dB Small Signal Gain
- +31 dBm Output IP3
- +16 P_{1 dB} @ 2 GHz
- 50 Ω Input and Output Match
- Uses Single DC Bias Supply
- Low Cost Plastic Package
- Available on Tape & Reel

Description

The GBH-114 is a general purpose broadband amplifier housed in a low cost industry standard Micro-X package. This amplifier has been designed as a cascadable 50 Ω gain block. It is also available in the ceramic Micro-X package. Applications include IF & RF amplification in broadband, wireless, WLAN, HLAN, DBS, TV tuner applications.

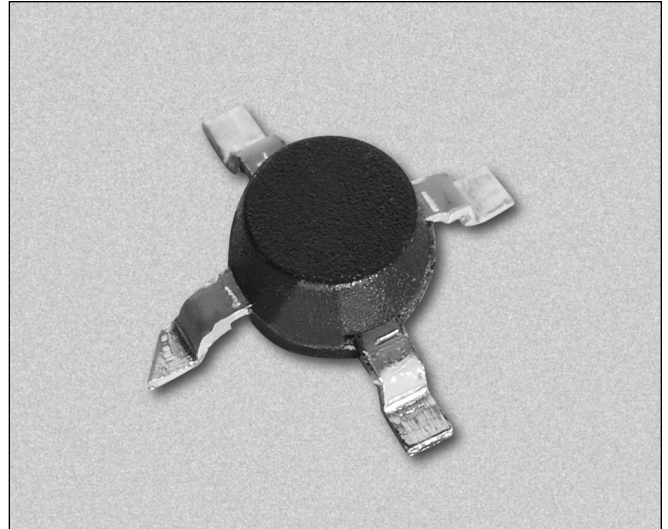

Absolute Maximum Ratings

Characteristic	Value
RF Input Power	20 dBm
Supply Current	120 mA
Supply Voltage	5 V
Power Dissipation @ 25°C T	600 mW
Operating Temperature	-45°C to +85°C
Storage Temperature	-65°C to +125°C

Electrical Characteristics at 25°C

Test Parameters V_{CC} = 4.7 V, I_C = 65 mA

Parameter	Symbol	Condition	Min.	Typ.	Max.	Unit
Small Signal Gain	G _P	I _C = 65 mA	13	15	16	dB
3 dB Gain Band	B W 3 dB			6.0		GHz
Noise Figure	NF	V _{CC} = 4.7, I _C = 65 mA F = 2.0 GHz		4.5	5.0	dB
Output Power at 1 dB Compression	P _{1 dB}	F = 2.0 GHz	15	16		dBm
Input and Output VSWR	VSWR	F = 0.1–5.0 GHz		1.5	1.7	
Output Third Order Intercept Point	IP3	V _{CC} = 4.7 V, I _C = 65 mA F = 0.1–2.0 GHz		31		dBm
Operating Voltage	VD	Amplifier DC Voltage	4.5	4.7	5.0	V
Reverse Isolation	Isol.	F = 0.1–4.0 GHz		17		dB
Gain Flatness	GHz	0.1–4.0 GHz		±1.0	±1.2	dB

Typical Performance Data at 25°C

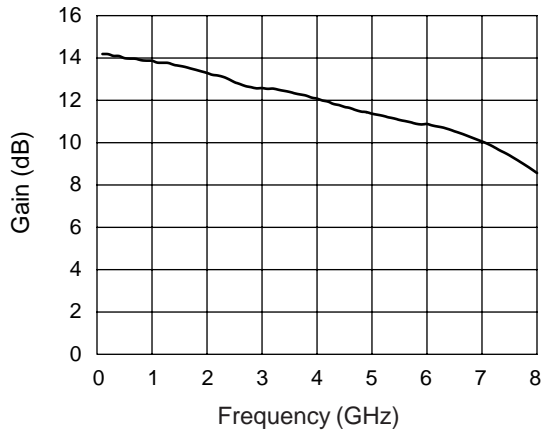

S₂₁ Gain vs. Frequency

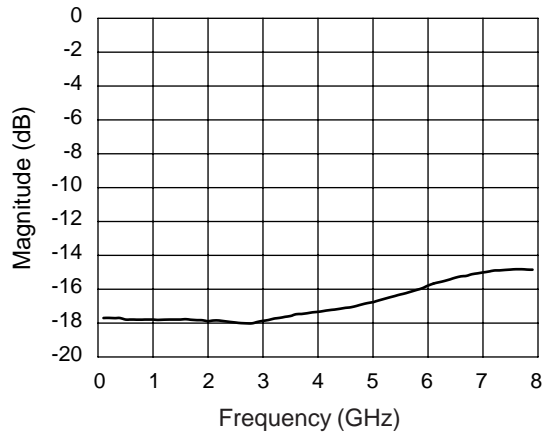

S₁₂ Reverse Isolation vs. Frequency

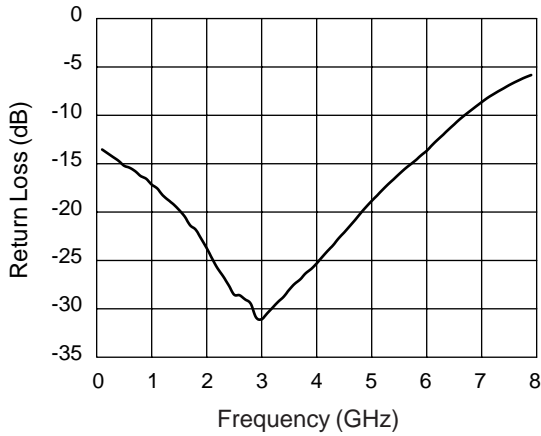

S₁₁ Input Return Loss vs. Frequency

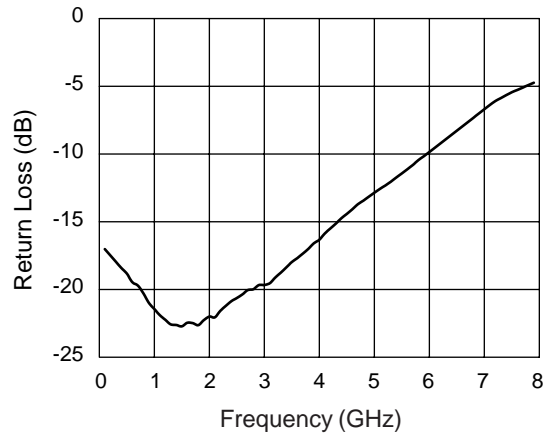

S₂₂ Output Return Loss vs. Frequency

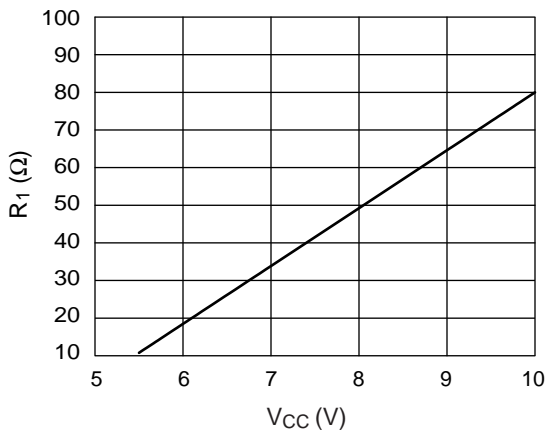

Bias Resistor Value vs. Supply Voltage

-214 Plastic Micro-X

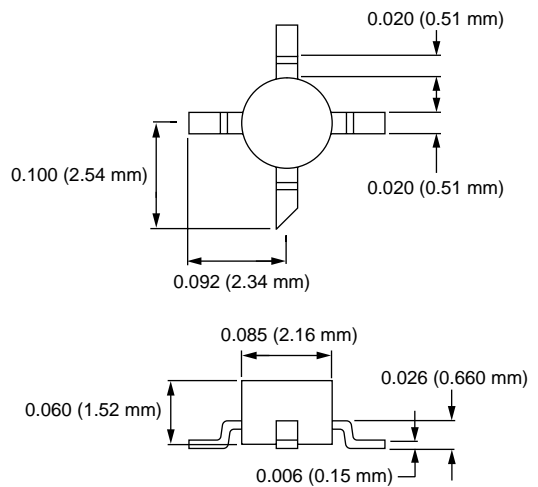

GBH Test Circuit

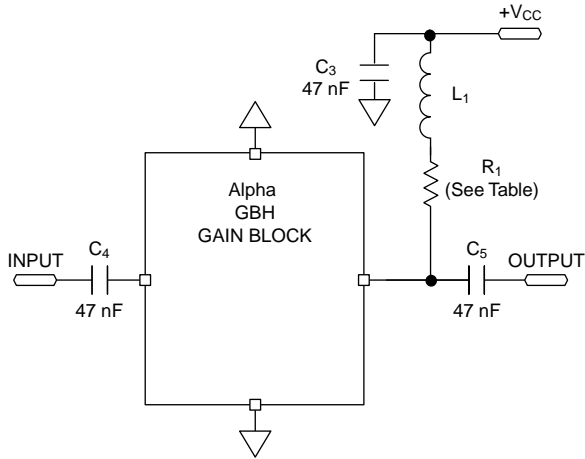

6 V Resistor Table

GBH112	$R_1 = 60 \Omega$
GBH114	$R_1 = 18 \Omega$
GBH120	$R_1 = 20 \Omega$
GBH121	$R_1 = 74 \Omega$