

ARX 4404 & 4407 Transceivers for MACAIR A3818, A5690, A5232, A4905 & MIL-STD-1553

Features

- ARX 4404 Transceiver meets MIL-STD-1553A&B, Macair A3818, A4905, A5232 and A5690 specs
- ARX 4407 Transceiver meets MIL-STD-1553 specs
- Operates with ± 15 Volts to ± 12 Volts power supply
- Direct replacement for CT 3231 and CT 3232
- Voltage source output for higher bus drive power
- Plug-in, flat package or low profile flat package
- Monolithic construction using linear ASICs
- Variable receiver threshold capability
- Low receiver data level versions, ARX 4451, 4467
- Processed and screened to Mil-STD-883 specs
- DESC SMD(Standard Military Drawing)



General Description:

The Aeroflex Laboratories transceiver models ARX 4404 and ARX 4407 are new generation monolithic transceivers which provide full compliance with Macair and MIL-STD-1553 data bus requirements.

The model ARX 4404 and model ARX 4407 perform the front-end analog function of inputting and outputting data through a transformer to a MIL-STD-1553 or Macair data bus. The ARX 4404 can be considered a "Universal" Transceiver in that it is compatible with MIL-STD-1553A, B, Macair A-3818, A-4905, A-5232 and A-5690. The ARX 4407 is compatible with MIL-STD-1553A and B.

Design of these transceivers reflects particular attention to active filter performance. This results in low bit and word error rate with superior waveform purity and minimal zero crossover distortion. The ARX4404 series active filter design has additional high frequency roll-off to provide the required Macair low harmonic distortion waveform without increasing the pulse delay characteristics significantly.

Efficient transmitter electrical and thermal design provides low internal power dissipation and heat rise at high and well as low duty cycles.

An optional receiver input threshold adjustment can be accomplished by the use of the "Set Internal Threshold" terminals.

Transmitter:

The Transmitter section accepts bi-phase TTL data at the input and

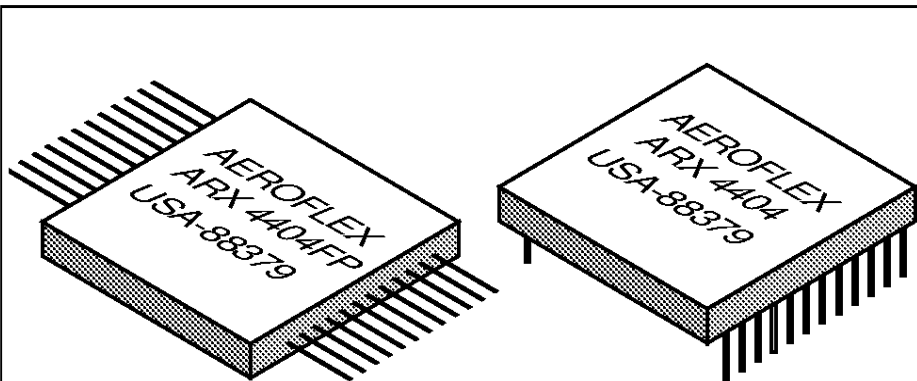

ARX 4404FP/4404 Transceivers

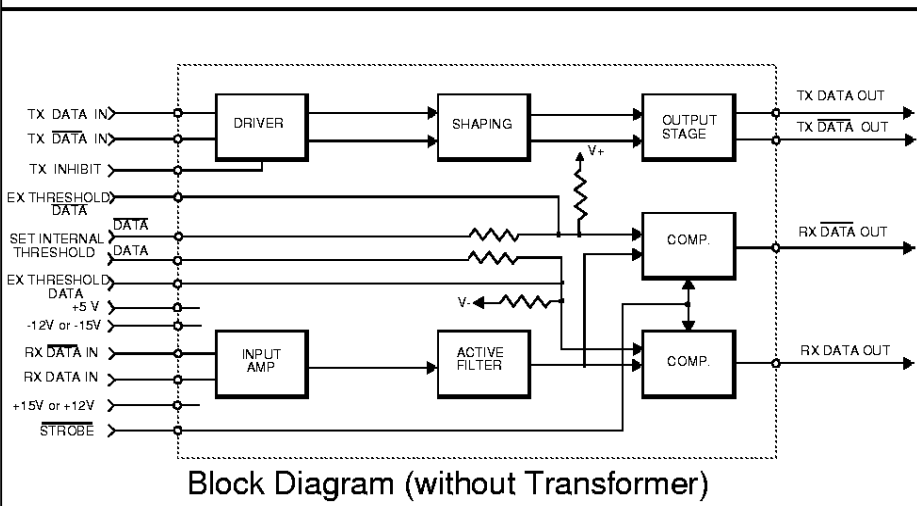

when coupled to the data bus with a 1:1 transformer, isolated on the data bus side with two 52.5 Ohm fault isolation resistors, and loaded by two 70 Ohm terminations plus additional receivers, the data bus signal produced is 7.0 volts minimum P-P at A-A'. (See Figure 5.) When both DATA and $\overline{\text{DATA}}$ inputs are held low or high, the transmitter output becomes a high impedance and is "removed" from the line. In addition, an overriding "INHIBIT" input provides for the removal of the transmitter output from the line. A logic "1" applied to the "INHIBIT" takes priority over the condition of the data inputs and disables the transmitter. (See Transmitter Logic Wave-

forms, Figure 1.) The transmitter utilizes an active filter to suppress harmonics above 1 MHz to meet Macair specifications A-3818, A-4905, A-5232 and A-5690. The transmitter may be safely operated for an indefinite period at 100% duty cycle into a data bus short circuit.

Receiver:

The Receiver section accepts bi-phase differential data at the input and produces two TTL signals at the output. The outputs are DATA and $\overline{\text{DATA}}$, and represent positive and negative excursions of the input beyond a pre-determined threshold. (See Receiver Logic Waveforms,

Figure 2.) The internal threshold is nominally set to detect data bus signals exceeding 1.05 Volts P-P and reject signals less than 0.6 volts P-P when used with a 1:1 turns ratio transformer. (See Figure 5 for transformer data and typical connection.) This threshold setting can be held by grounding the appropriate pins or modified with the use of external resistors.

A low level at the Strobe input inhibits the DATA and $\overline{\text{DATA}}$ outputs. If unused, a 2K pull-up to +5 Volts is recommended

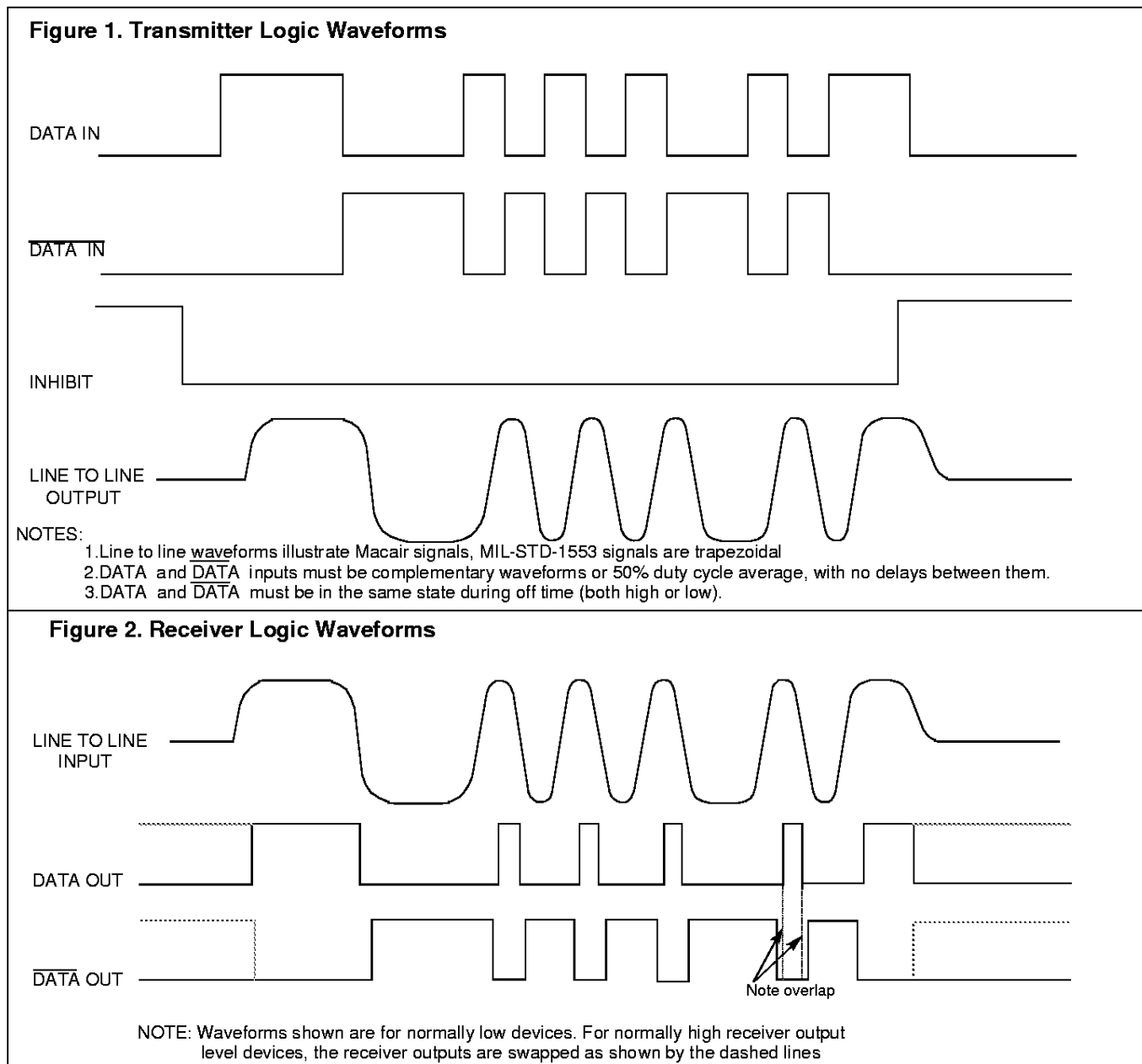

Absolute Maximum Ratings

Operating case temperature	-55°C to +125°C	
Storage case temperature	-65°C to +150 °C	
Power supply Voltages	±15 V P.S. to ±18V MAX	+5 V P.S. to +7V MAX
Logic input Voltage	-0.3 V to +5.5 V	
Receiver differential input	±40 V	
Receiver input voltage (common mode)	±10V	
Driver peak output current	300 mA	
Total package power dissipation over the full operating case temperature range	2.4 Watts	
Power Dissipation for hottest die, (100% duty cycle)	600 mW	
Maximum junction to case temperature rise for the hot-test device (100 % duty cycle)	36°C	
Junction-Case, Thermal resistance for hottest device	60°C/W	

Electrical Characteristics, Transmitter Section

Input Characteristics, TX DATA in or TX DATA in

Parameter	Condition	Symbol	Min	Typ	Max	Unit
"0" Input Current	$V_{IN} = 0.4 V$	I_{ILD}		-0.2	-0.4	mA
"1" Input Current	$V_{IN} = 2.7 V$	I_{IHD}		1.0	40	μA
"0" Input Voltage		V_{IHD}			0.7	V
"1" Input Voltage		V_{IHD}	2.0			V

Inhibit Characteristics

"0" Input Current	$V_{IN}=0.4V$	I_{ILI}		-0.2	-0.4	mA
"1" Input Current	$V_{IN}=2.7V$	I_{IHI}		1.0	40	μA
"0" Input Voltage		V_{ILI}			0.7	V
"1" Input Voltage		V_{IHI}	2			V
Delay from TX inhibit(0→1) to inhibited output	Note 1	t_{DXOFF}		300	450	nS
Delay from TX inhibit, (1→0) to active output	Note 1	t_{DXON}		300	450	nS
Differential output noise, inhibit mode		V_{NOI}		0.8	10	mV p-p
Differential output impedance (inhibited)	Note 2	Z_{OI}	2K			Ω

Output Characteristics

Differential output level	$R_L=35 \Omega$	V_O	7	7.5	9	V p-p
Rise and fall times (10% to 90% of p-p output)		t_r	200	250	300	nS
Output offset at point A-A' on Fig 5., 2.5 μS after midpoint crossing of the parity bit of the last word of a 660 μS message	$R_L=35 \Omega$	V_{OS}			±90	mV peak
Delay from 50% point of TX DATA or TX DATA input to zero crossing of differential signal. (note 1.)	ARX4404	t_{DTX}		240	300	nS
	ARX4407			150	300	nS

Electrical Characteristics, Receiver Section

Parameter	Condition	Symbol	Min	Typ	Max	Unit
Differential Input Impedance	f= 1MHz	Z_{in}	20K	100K		Ω
Differential Input Voltage Range		V_{IDR}			40	V p-p
Input Common Mode Voltage Range	Note 1	V_{ICR}	10			V p-p
Common Mode Rejection Ratio Note 3	Note 1	CMRR	40			dB

Strobe Characteristics (Logic "0" inhibits output)

"0" Input Current	$V_S=0.4 V$	I_{IL}		-0.2	-0.4	mA
"1" Input Current	$V_S=2.7V$	I_{IH}		-1.0	+40	μA
"0" Input Voltage		V_{IL}			0.7	V
"1" Input Voltage		V_{IH}	2.0			V
Strobe Delay (turn-on or turn-off)	Note 1.	t_{SD}			150	nS

Threshold Characteristics (Sinewave input)

Internal Threshold Voltage (referred to the bus) pins 6 and 11 grounded	100KHz-1 MHz	V_{TH}	0.60	0.8	1.15	V_{P-P}
External threshold control (pins 6&11 open, resistors from pin 5 and 12 to ground)	Max R= 10K Ω	R_{TH} / V_{TH}		4000		Ohms/V p-p

Output Characteristics, RX DATA and RX DATA

"1" State	$I_{OH} = -0.4 mA$	V_{OH}	2.5	3.6		V
"0" State	$I_{OL} = 4 mA$	V_{OL}		0.35	0.5	V
Delay, (average)from differential input zero crossings to RX DATA and RX DATA output 50% points	Note 1	t_{DRX}		300	450	nS

Power Data

Power Supply Currents (Power supplies set at +15V, -15V, +5V)

Duty Cycle	+V	-V	5V
Transmitter Standby	60mA	75mA	35mA
25% duty cycle Note 1	80mA	95mA	
50% duty cycle	105mA	120mA	
100% duty cycle Note 1	160mA	180mA	

Recommended Power Supply Voltage Range

+V	+11.4 Volts to +15.75 Volts
-V	-11.4 Volts to -15.75 Volts
Logic	+4.5 Volts to + 5.5 Volts

Figure 3. Transmitter (TX) Output Wave form

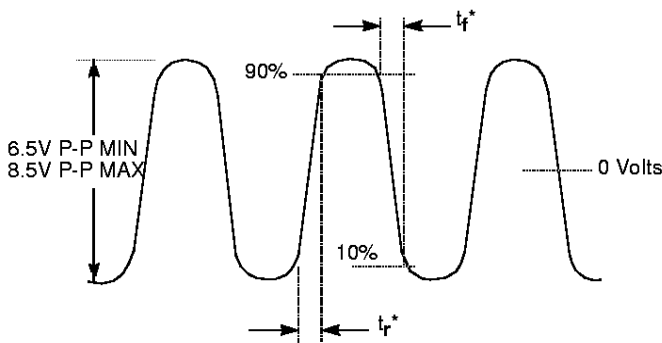

* Rise and fall times measured at point A-A' in Fig 5

Figure 4. Transmitter (TX) Output offset

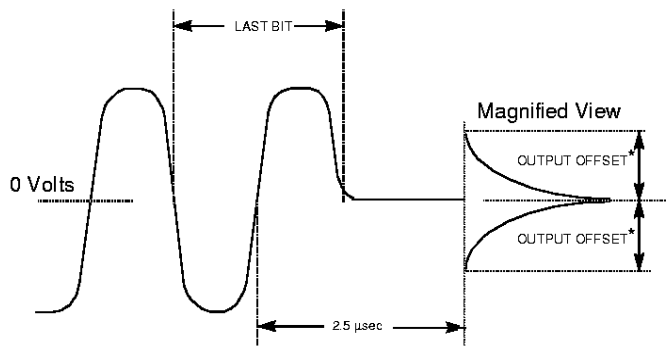

*Offset measured at point A-A' in Fig 5

Figure 5. Typical Transformer connection

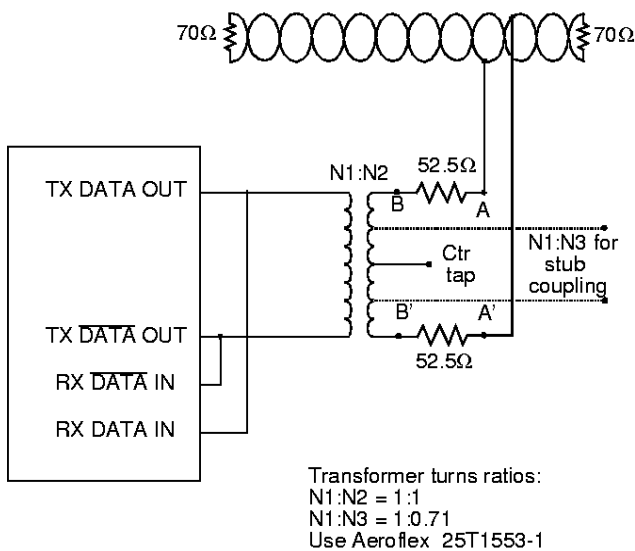
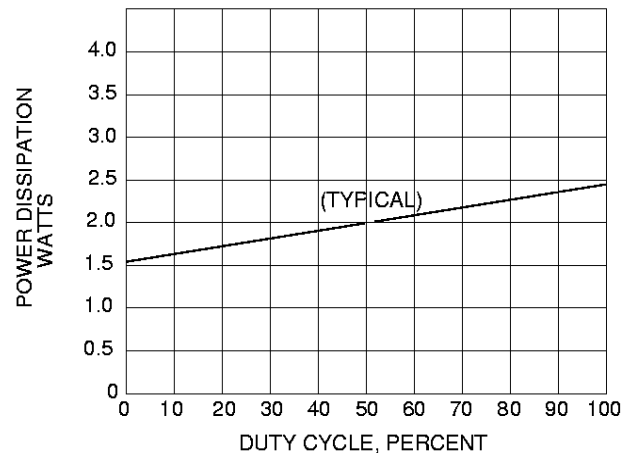

Figure 6. Power Dissipation vs. Duty Cycle



NOTES

1. Characteristics guaranteed by design, not production tested.
2. Measured from 75kHz to 1MHz at point A-A' with transformer self impedance of 3KΩ minimum, power on or off.
3. Specifications apply over the temperature range of -55°C to +125°C (case temperature) unless otherwise noted.
4. All typical values are measured at +25°C

The information contained in this data sheet is believed to be accurate; however, Aeroflex Circuit Technology, assumes no responsibility for its use, and no licence or rights are granted by implication or otherwise in connection therewith.

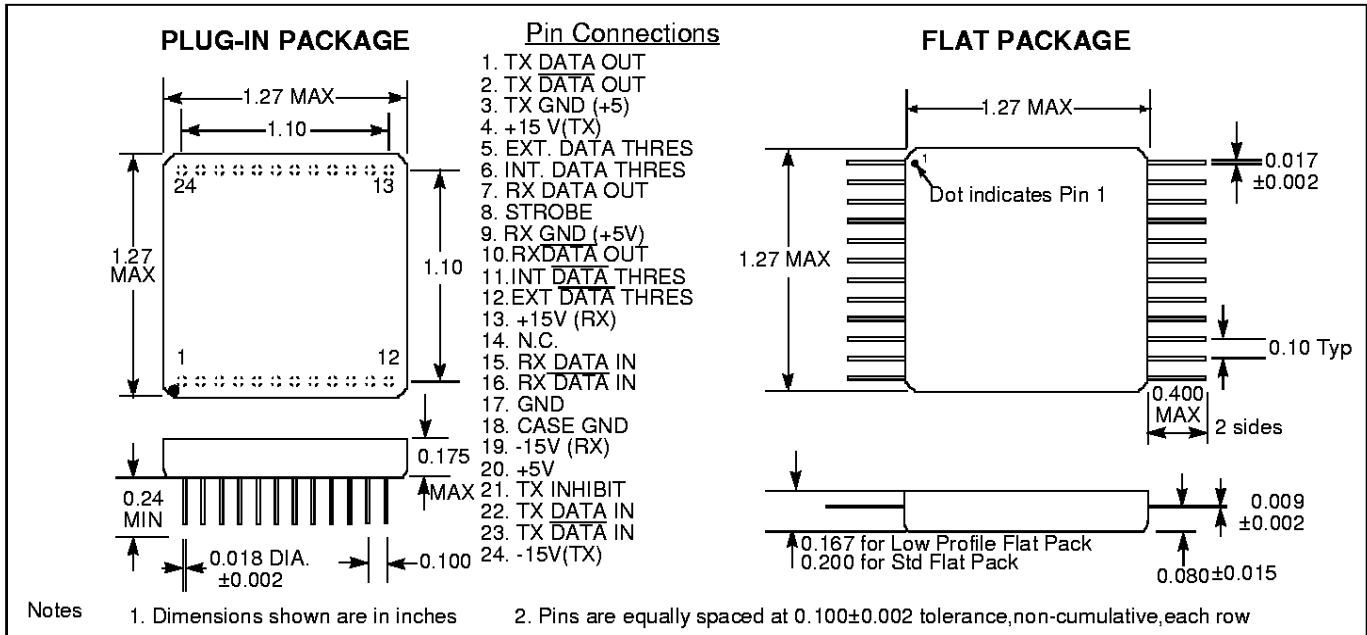
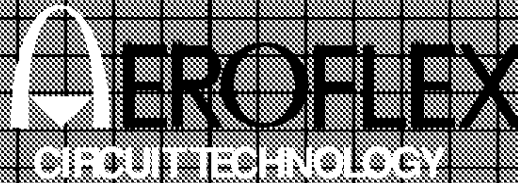

Configurations and Ordering Information

Model No.	DESC No.	Receiver Data level	Case	Specs.
ARX 4404	5962-9174909HXX	Normally High	Plug In	1553 & Macair
ARX 4404FP	5962-9174909HYX	Normally High	Flat Pack	1553 & Macair
ARX 4404LPFP	5962-9174909HTX	Normally High	Low Profile Flat Pack	1553 & Macair
ARX 4407	5962-9174908HXX	Normally High	Plug In	1553
ARX 4407FP	5962-9174908HYX	Normally High	Flat Pack	1553
ARX 4407LPFP	5962-9174908HTX	Normally High	Low Profile Flat Pack	1553
ARX 4451	5962-9208502XX	Normally Low	Plug In	1553 & Macair
ARX 4451FP	5962-9208502YX	Normally Low	Flat Pack	1553 & Macair
ARX 4451LPFP	To Be Assigned	Normally Low	Low Profile Flat Pack	1553 & Macair
ARX 4467	To Be Assigned	Normally Low	Plug In	1553
ARX 4467FP	To Be Assigned	Normally Low	Flat Pack	1553
ARX 4467LPFP	To Be Assigned	Normally Low	Low Profile Flat Pack	1553

Aeroflex Circuit Technology
35 South Service Road
Plainview New York 11803

Telephone: (516) 694-6700
FAX: (516) 694-6715
Toll Free Inquiries: 1-(800)THE-1553