

Document	
ECN No.	
Date of Issue	September 5, 1990
Status	Preliminary Specification
RF Communications	

NE/SA576

Low power compandor

DESCRIPTION

The NE/SA576 is a unity gain level programmable compandor designed for low power applications. The NE576 is internally configured as an expander and a compressor to minimize external component count.

The NE576 can operate at 1.8V. During normal operations, the NE576 can operate from at least a 2V battery. If the battery voltage drops to 1.8V, this part will still continue to function, however, turning on the part at a V_{CC} of 1.8V requires two external resistors to bring V_{REF} to half V_{CC} . One resistor connects between V_{CC} and V_{REF} ; the other connects from V_{REF} to ground. A typical value for these external resistors is approximately 20k. A lower value can be used, but the power consumption will go up.

The NE576 is available in a 14-pin plastic DIP and SO packages.

FEATURES

- Operating voltage range: 1.8V to 7V
- Low power consumption (1.4mA @ 3.6V)
- Over 80dB of dynamic range
- Wide input/output swing capability (rail-to-rail)
- Low external component count
- ESD hardened

APPLICATIONS

- Cordless telephone
- Consumer audio
- Wireless microphones
- Modems
- Electric organs
- Hearing aids
- Automatic level control

PIN CONFIGURATION

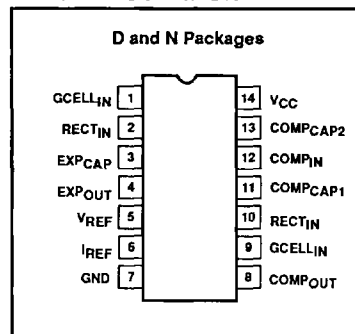

ORDERING INFORMATION

DESCRIPTION	TEMPERATURE RANGE	ORDER CODE
14-Pin Plastic DIP	0 to +70°C	NE576N
14-Pin Plastic SO	0 to +70°C	NE576D
14-Pin Plastic DIP	-40 to +85°C	SA576N
14-Pin Plastic SO	-40 to +85°C	SA576D

Low power compandor

NE/SA576

BLOCK DIAGRAM and TEST AND APPLICATION CIRCUIT

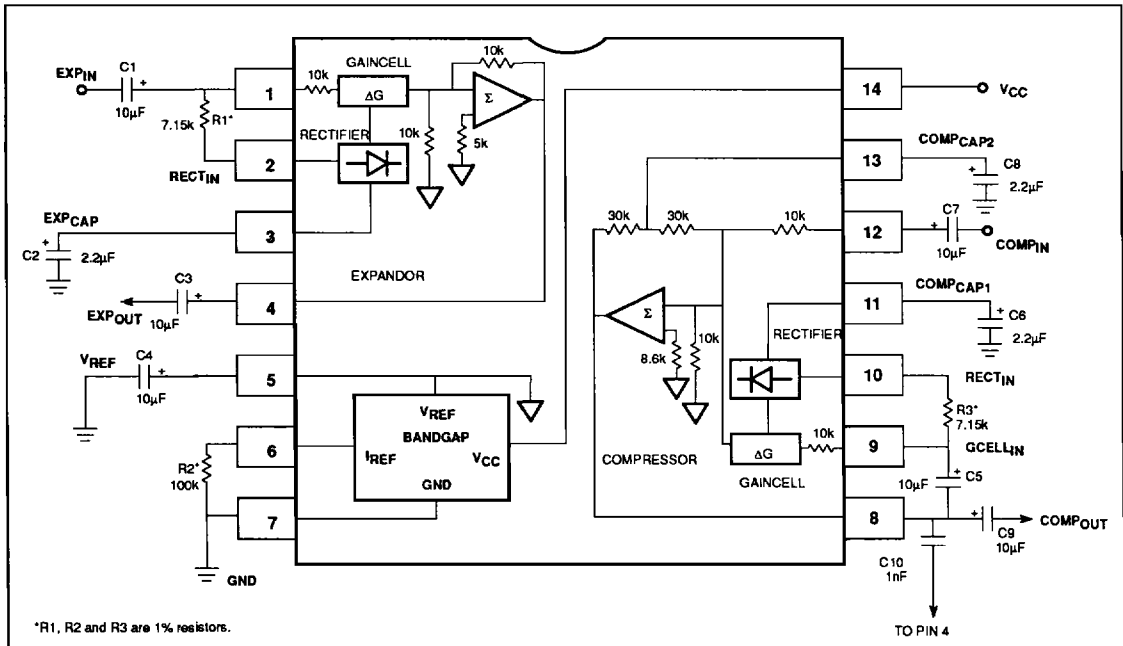

Low power compandor

NE/SA576

ABSOLUTE MAXIMUM RATINGS

SYMBOL	PARAMETER	RATING		UNITS	
		NE576	SA576		
V_{CC}	Supply voltage	8	8	V	
T_A	Operating ambient temperature range	0 to +70	-40 to +85	°C	
T_{STG}	Storage temperature range	-65 to +150	-65 to +150	°C	
θ_{JA}	Thermal impedance	DIP	90	90	°C/W
		SO	125	125	°C/W

ELECTRICAL CHARACTERISTICS

$T_A = 25^\circ\text{C}$, $V_{CC} = 3.6\text{VDC}$, compandor 0dB level = $-20\text{dBV} = 100\text{mV}_{\text{RMS}}$, output load $R_L = 10\text{k}\Omega$, Freq = 1kHz, unless otherwise specified. R1, R2 and R3 are 1% resistors.

SYMBOL	PARAMETER	TEST CONDITIONS	LIMITS			UNITS
			NE/SA576			
			MIN	TYP	MAX	
V_{CC}	Supply voltage ¹		2	3.6	7	V
I_{CC}	Supply current	No signal $R_2 = 100\text{k}\Omega$		1.4	3	mA
V_{REF}	Reference voltage ²	$V_{CC} = 3.6\text{V}$		1.8		V
R_L	Summing amp output load		10			$\text{k}\Omega$
THD	Total harmonic distortion	1kHz, 0dB, BW = 3.5kHz		0.1	1.5	%
E_{NO}	Expandor output noise voltage	BW = 20kHz, $R_S = 0\Omega$			30	μV
0dB	Unity gain level	0dB at 1kHz	-1.5		1.5	dB
V_{OS}	Output voltage offset	No signal	-150		150	mV
	Expandor output DC shift	No signal to 0dB	-100		100	mV
	Tracking error relative to 0dB output		-1.0		1.0	dB
	Crosstalk, COMP to EXP	1kHz, 0dB, $C_{REF} = 10\mu\text{F}$		-80		dB
V_O	Output swing low			0.2		V
	Output swing high			$V_{CC} - 0.2$		V

NOTE:

11. Operation down to $V_{CC} = 1.8\text{V}$ is possible, see description on front page of NE576 data sheet.

12. Reference voltage, V_{REF} , is typically at $1/2 V_{CC}$.