

SN54F520, SN54F521, SN74F520, SN74F521 8-BIT IDENTITY COMPARATORS

D2932, MARCH 1987—REVISED JANUARY 1989

- Compares Two 8-Bit Words
- 'F520 has 20-k Ω Pull-up Resistors on Q Inputs
- Package Options Include Plastic "Small Outline" Packages, Ceramic Chip Carriers, and Standard Plastic and Ceramic 300-mil DIPs
- Dependable Texas Instruments Quality and Reliability

description

These identity comparators perform comparisons on two eight-bit binary or BCD words. The 'F520 and F521 provide $\overline{P=Q}$ outputs. The 'F520 devices feature 20-k Ω pull-up termination resistors on the Q inputs for analog or switch data.

The SN54F520 and SN54F521 are characterized for operation over the full military temperature range of -55°C to 125°C . The SN74F520 and SN74F521 are characterized for operation from 0°C to 70°C .

logic symbol†

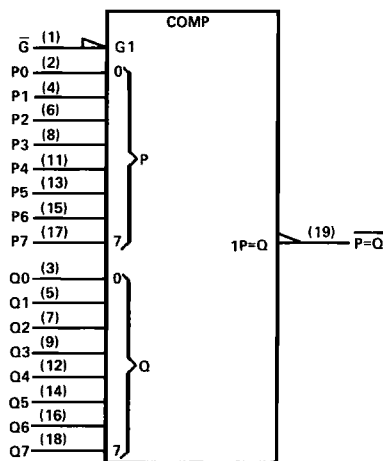

†This symbol is in accordance with ANSI/IEEE Std 91-1984 and IEC Publication 617-12.

SN54F520, SN54F521 . . . J PACKAGE
SN74F520, SN74F521 . . . DW OR N PACKAGE
(TOP VIEW)

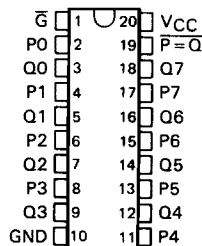

SN54F520, SN54F521 . . . FK PACKAGE
(TOP VIEW)

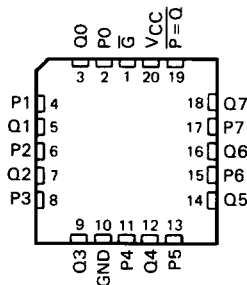

FUNCTION TABLE

INPUTS		OUTPUT
DATA P, Q	ENABLE G-bar	$\overline{P=Q}$
P = Q	L	L
P \neq Q	X	H
X	H	H

2

Data Sheets

SN54F520, SN54F521, SN74F520, SN74F521
8-BIT IDENTITY COMPARATORS

logic diagram (positive logic)

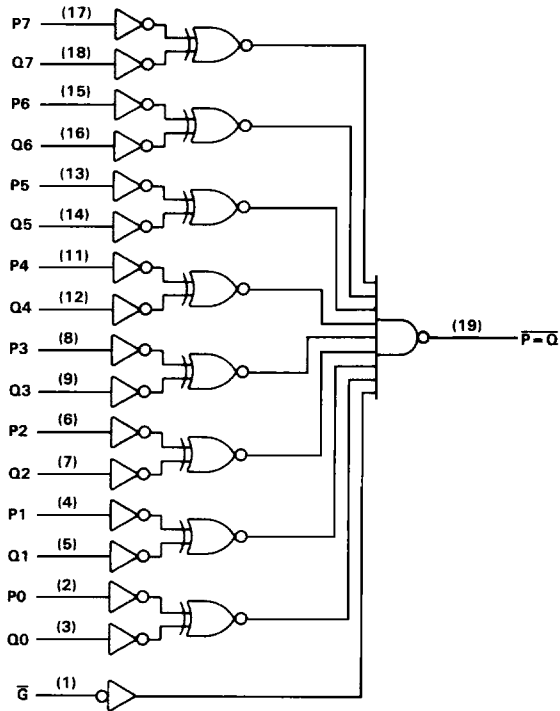

NOTE: The 'F520 has a 20-kΩ pullup resistors on the Q inputs.

absolute maximum ratings over operating free-air temperature range (unless otherwise noted)

Supply voltage, V_{CC}	-0.5 V to 7 V
Input voltage [†]	-1.2 V to 7 V
Input current	-30 mA to 5 mA
Voltage applied to any output in the high state	-0.5 V to V_{CC}
Current into any output in the low state	40 mA
Operating free-air temperature range: SN54F520, SN54F521	-55 °C to 125 °C
SN74F520, SN74F521	0 °C to 70 °C
Storage temperature range	-65 °C to 150 °C

[†]The input voltage ratings may be exceeded provided the input current ratings are observed.

SN54F520, SN74F520 8-BIT IDENTITY COMPARATORS

recommended operating conditions

	SN54F520			SN74F520			UNIT
	MIN	NOM	MAX	MIN	NOM	MAX	
V _{CC} Supply voltage	4.5	5	5.5	4.5	5	5.5	V
V _{IH} High-level input voltage	2			2			V
V _{IL} Low-level input voltage	0.8			0.8			V
I _{IK} Input clamp current	-18			-18			mA
I _{OH} High-level output current	-1			-1			mA
I _{OL} Low-level output current	20			20			mA
T _A Operating free-air temperature	-55	125		0	70		°C

electrical characteristics over recommended operating free-air temperature range (unless otherwise noted)

	TEST CONDITIONS		SN54F520			SN74F520			UNIT
			MIN	TYP [†]	MAX	MIN	TYP [†]	MAX	
V _{IK}	V _{CC} = 4.5 V,	I _I = -18 mA	-1.2			-1.2			V
V _{OH}	V _{CC} = 4.5 V,	I _{OH} = -1 mA	2.5	3.4		2.5	3.4	V	
	V _{CC} = 4.75 V,	I _{OH} = -1 mA				2.7			
V _{OL}	V _{CC} = 4.5 V,	I _{OL} = 20 mA	0.30	0.5		0.3	0.5	V	
I _I	\bar{Q} and P inputs	V _{CC} = 5.5 V, V _I = 7 V	0.1			0.1			mA
	Q inputs	V _{CC} = 5.5 V, V _I = 5.5 V	0.1			0.1			
I _{IH}	\bar{Q} and P inputs	V _{CC} = 5.5 V, V _I = 2.7 V	20			20			μA
	Q inputs		-0.3			-0.3			
I _{IL}	\bar{Q} and P inputs	V _{CC} = 5.5 V, V _I = 0.5 V	-0.6			-0.6			mA
	Q inputs		-1			-1			
I _{OS} [‡]	V _{CC} = 5.5 V,	V _O = 0	-60	-150		-60	-150	mA	
I _{CC}	V _{CC} = 5.5 V,	See Note 1	21	32		21	32	mA	

switching characteristics (see Note 2)

PARAMETER	FROM (INPUT)	TO (OUTPUT)	V _{CC} = 5 V, C _L = 50 pF, R _L = 500 Ω, T _A = 25°C			V _{CC} = 4.5 V to 5.5 V, C _L = 50 pF, R _L = 500 Ω, T _A = MIN to MAX [§]				UNIT
			'F520			SN54F520		SN74F520		
			MIN	TYP	MAX	MIN	MAX	MIN	MAX	
t _{PLH}	P or Q	$\bar{P} = \bar{Q}$	3.9	5.7	7.7	3.7	10.2	3.7	8.7	ns
t _{PHL}			4.7	7	9.3	4.4	11.3	4.4	10.3	
t _{PLH}	\bar{Q}	$\bar{P} = \bar{Q}$	3.5	4.6	5.8	3.4	7	3.4	6.4	ns
t _{PHL}			5.2	7.5	9.5	4.9	11.2	4.9	10.4	

[†] All typical values are at V_{CC} = 5 V, T_A = 25°C.

[‡] Not more than one output should be shorted at a time, and the duration of the short circuit should not exceed one second.

[§] For conditions shown as MIN or MAX, use the appropriate value specified under Recommended Operating Conditions.

NOTES: 1. I_{CC} is measured with all inputs at 4.5 V.

2. Load circuits and waveforms are shown in Section 1.

2

Data Sheets

SN54F521, SN74F521

8-BIT IDENTITY COMPARATORS

recommended operating conditions

		SN54F521			SN74F521			UNIT
		MIN	NOM	MAX	MIN	NOM	MAX	
V _{CC}	Supply voltage	4.5	5	5.5	4.5	5	5.5	V
V _{IH}	High-level input voltage	2			2			V
V _{IL}	Low-level input voltage	0.8			0.8			V
I _{IK}	input clamp current	-18			-18			mA
I _{OH}	High-level output current	-1			-1			mA
I _{OL}	Low-level output current	20			20			mA
T _A	Operating free-air temperature	-55		125	0		70	°C

electrical characteristics over recommended operating free-air temperature range (unless otherwise noted)

PARAMETER	TEST CONDITIONS	SN54F521			SN74F521			UNIT
		MIN	TYP [†]	MAX	MIN	TYP [†]	MAX	
V _{IK}	V _{CC} = 4.5 V, I _I = -18 mA	-1.2			-1.2			V
V _{OH}	V _{CC} = 4.5 V, I _{OH} = -1 mA	2.5	3.4		2.5	3.4		V
	V _{CC} = 4.75 V, I _{OH} = -1 mA				2.7			
V _{OL}	V _{CC} = 4.5 V, I _{OL} = 20 mA	0.3		0.5	0.3		0.5	V
I _I	V _{CC} = 5.5 V, V _I = 7 V	100			100			μA
I _{IH}	V _{CC} = 5.5 V, V _I = 2.7 V	20			20			μA
I _{IL}	V _{CC} = 5.5 V, V _I = 0.5 V	-0.6			-0.6			mA
I _{OS} [‡]	V _{CC} = 5.5 V, V _O = 0	-60		-150	-60		-150	mA
I _{CC}	V _{CC} = 5.5 V, See Note 1	21		32	21		32	mA

switching characteristics (see Note 2)

PARAMETER	FROM (INPUT)	TO (OUTPUT)	V _{CC} = 5 V, C _L = 50 pF, R _L = 500 Ω, T _A = 25°C			V _{CC} = 4.5 V to 5.5 V, C _L = 50 pF, R _L = 500 Ω, T _A = MIN to MAX [§]				UNIT
			F521			SN54F521		SN74F521		
			MIN	TYP	MAX	MIN	MAX	MIN	MAX	
t _{PLH}	P or Q	P = Q	2.7	6.6	10	2.7	15	2.7	11	ns
t _{PHL}			3.7	6.6	10	3.2	12	3.2	11	
t _{PLH}	Q	P = Q	2.2	4.6	6.5	2.2	8.5	2.2	7.5	ns
t _{PHL}			2.7	6.1	9	2.7	13.5	2.7	10	

[†]All typical values are at V_{CC} = 5 V, T_A = 25°C.

[‡]Not more than one output should be shorted at a time, and the duration of the short circuit should not exceed one second.

[§]For conditions shown as MIN or MAX, use the appropriate value specified under Recommended Operating Conditions.

NOTES: 1. I_{CC} is measured with all inputs at 4.5 V.

2. Load circuits and waveforms are shown in Section 1.

2

Data Sheets