

EAHP1313WB0



Features

- High Power COB & High CRI LED
- Multi-Chip Solution
- Dimension: 13 mm x 13 mm x 1.6 mm
- Main Parameters: Luminous Flux, Forward Voltage, Chromaticity and Color Rendering Index
- RoHS compliant
- Energy Star / ANSI Compliant Binning Structure
- Typical Viewing Angle: 115°

Description

Everlight Americas EAHP1313WB0 is an aluminum substrate based LED achieving high efficiency while maintaining high CRI at Energy Star / ANSI color temperature ranges.

Applications

- Replacement Bulb
- Indoor General Lighting
- Recessed Can Lighting

Absolute Maximum Ratings

Parameter	Symbol	Ratings	Unit
Max. DC Forward Current (mA)	I_F	360 _[1]	mA
Max. Peak Pulse Current (mA)	I_{Pulse}	720 _[2]	mA
Power Dissipation	P_d	14.7	W
Thermal Resistance(junction to board)	R_{th}	2	°C/W
Max. Junction Temperature	T_J	120	°C
Operating Temperature	T_{Opr}	-40 ~ +85	°C
Storage Temperature	T_{Stg}	-40 ~ +85	°C

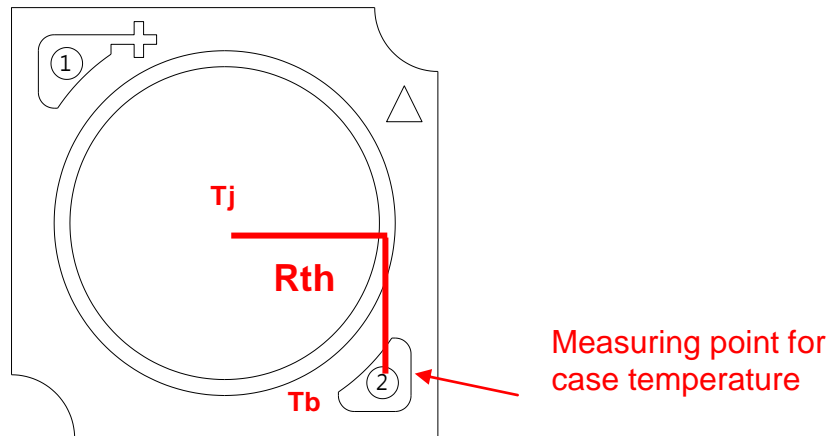

Notes:

1. For optimal performance, Everlight Americas recommends 180mA operation.
2. $t_p \leq 100ms$, Duty cycle = 25%
3. The EAHP1313WB0 LEDs are not designed for reverse bias use.
4. Power dissipation and forward current are the value when the module temperature is set lower than the rating by using an adequate heat sink.

PN of the EAHP1313WB0: White LEDs



Order Code of EAHP1313WB0	Minimum Luminous Flux (lm) @T _j =25°C	Typical Luminous Flux (lm) @T _j =25°C	CCT (K)	Forward Voltage (V)	Forward Current (mA)	CRI (min.)
EAHP1313WB0	750	830	40K-1~40K-4	33.0~41.0	180	80

Notes:

1. CRI measurement tolerance: ±2.
2. Luminous flux measurement tolerance: ±10%.
3. The data of luminous flux measured at thermal pad=25°C
4. Typical luminous flux or light output performance is operated within the condition guided by this datasheet.

Product Binning

Luminous Flux Bins

Group	Bin	Minimum Photometric Flux (lm)	Maximum Photometric Flux (lm)
N	8	750	900

Neutral-White Bin Structure

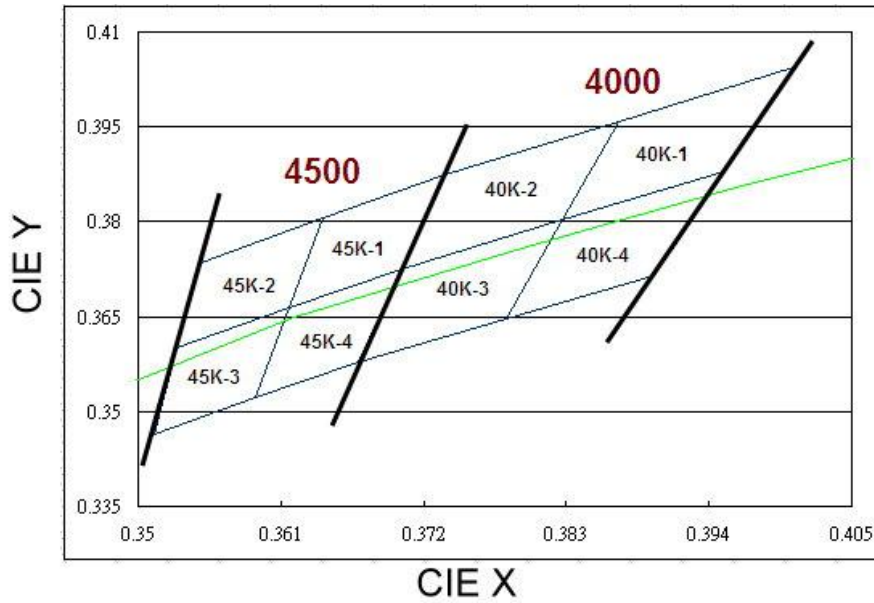

Neutral-White Bin Coordinates

4000K

Bin	CIE X	CIE Y
40K-1	0.3825	0.3798
	0.3869	0.3958
	0.4006	0.4044
	0.3950	0.3875
Reference Range: 3710~3967K		

Bin	CIE X	CIE Y
40K-2	0.3702	0.3722
	0.3736	0.3874
	0.3869	0.3958
	0.3825	0.3798
Reference Range: 3967~4259K		

Bin	CIE X	CIE Y
40K-4	0.3783	0.3646
	0.3825	0.3798
	0.3950	0.3875
	0.3898	0.3716
Reference Range: 3710~3967K		

Bin	CIE X	CIE Y
40K-3	0.3670	0.3578
	0.3702	0.3722
	0.3825	0.3798
	0.3783	0.3646
Reference Range: 3967~4259K		

Notes:

1. Color coordinates measurement allowance : ± 0.01

Forward Voltage Bins

Bin	Minimum Forward Voltage (V)	Maximum Forward Voltage (V)
W4	33.0	41.0

Notes:

1. Forward voltage measurement tolerance: $\pm 2\%$.
2. Forward voltage bins are defined at $I_f=180\text{mA}$ operation.
3. Other Forward Voltage bins for White LEDs available upon request. Please contact your local Everlight Americas sales office.

Mechanical Dimension

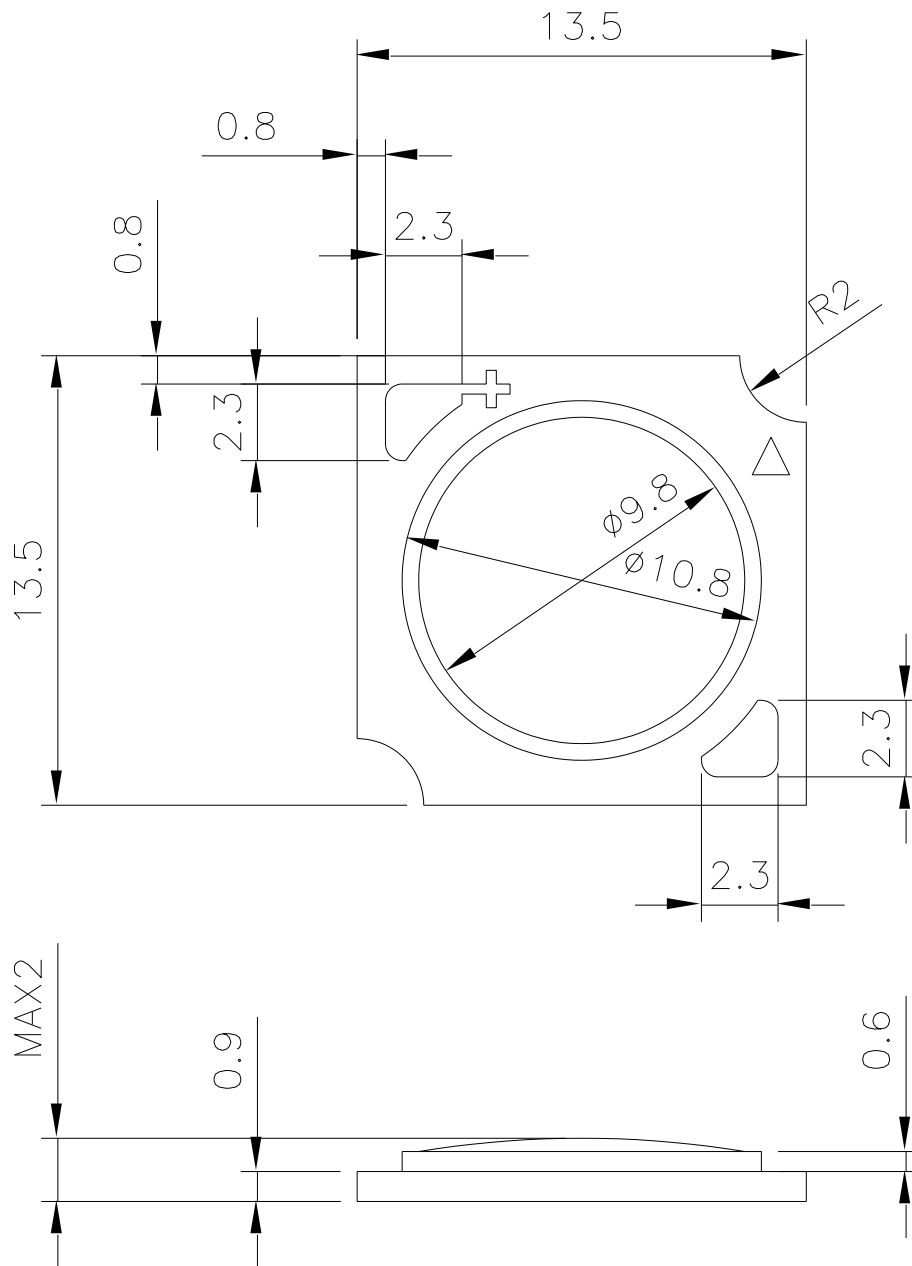

 12 series × 3 parallel

Note:

1. Dimensions are in millimeters.
2. Tolerances unless mentioned are ± 0.1 mm.

Pad Configuration

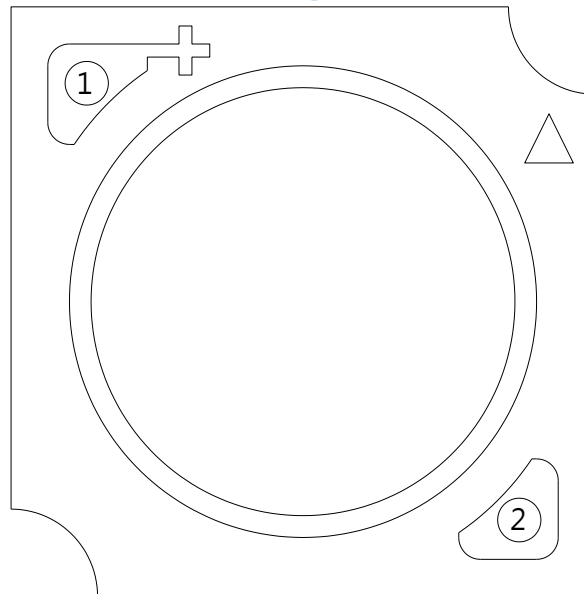

PAD	FUNCTION
1	ANODE
2	CATHODE

Typical Electro-Optical Characteristic Curve

Relative Spectral Distribution
@ Substrate Temperature = 25°C

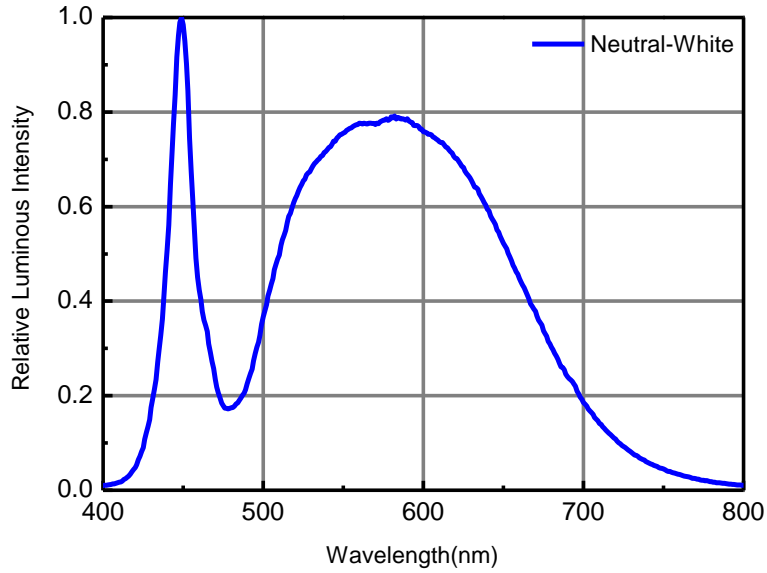

Relative Luminous Flux vs. Substrate Temperature
@Forward Current = 180mA

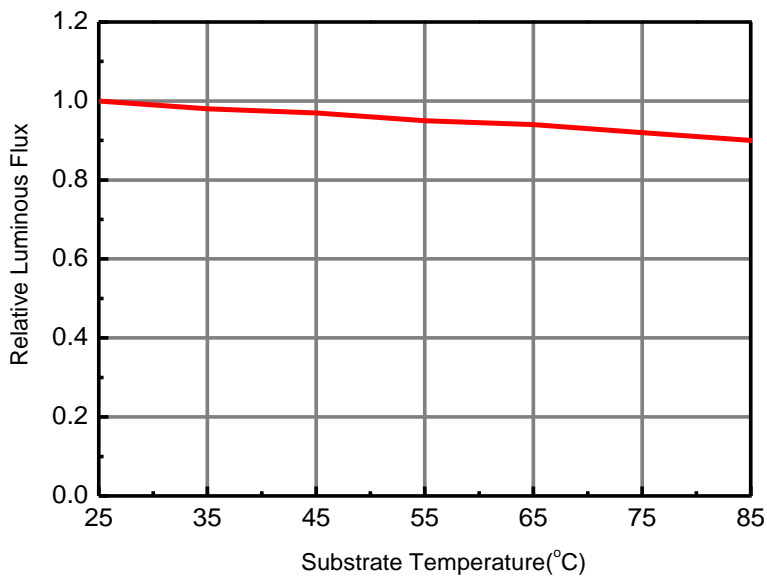

Forward Voltage vs. Forward Current
@ Substrate Temperature = 25°C

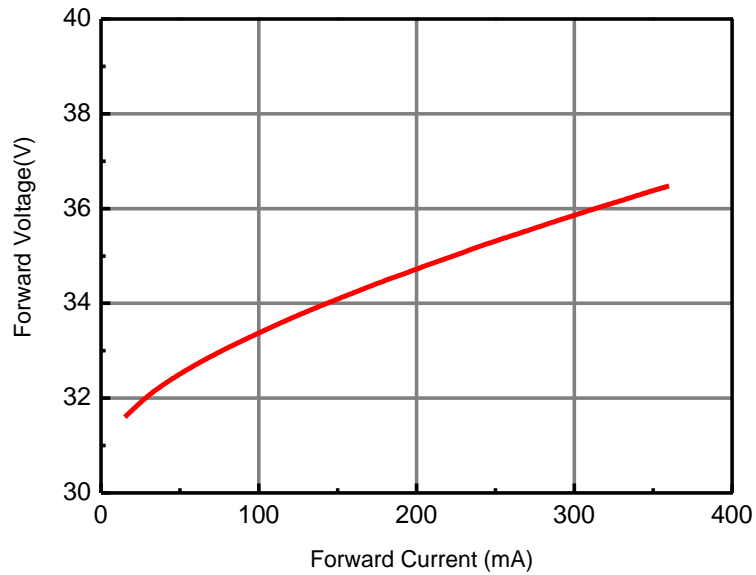

Luminous Flux vs. Forward Current
@ Substrate Temperature = 25°C

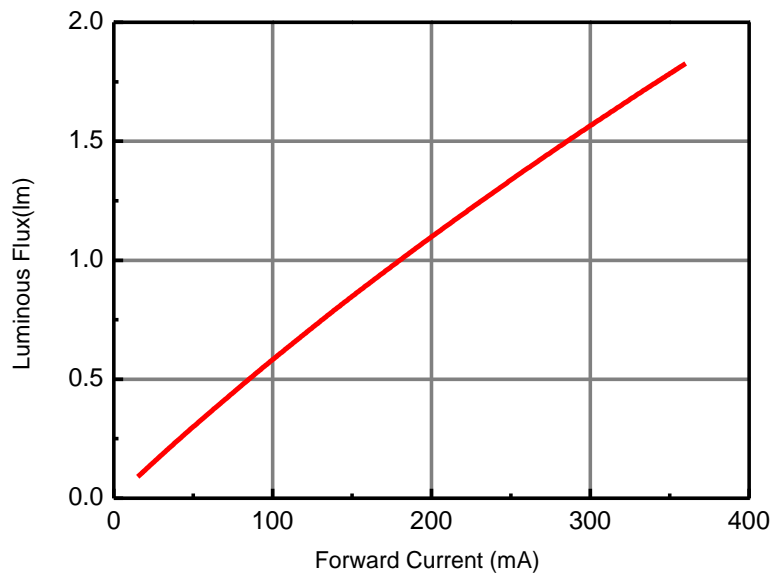

Correlated Color Temperature vs. Forward Current
@ Substrate Temperature = 25°C

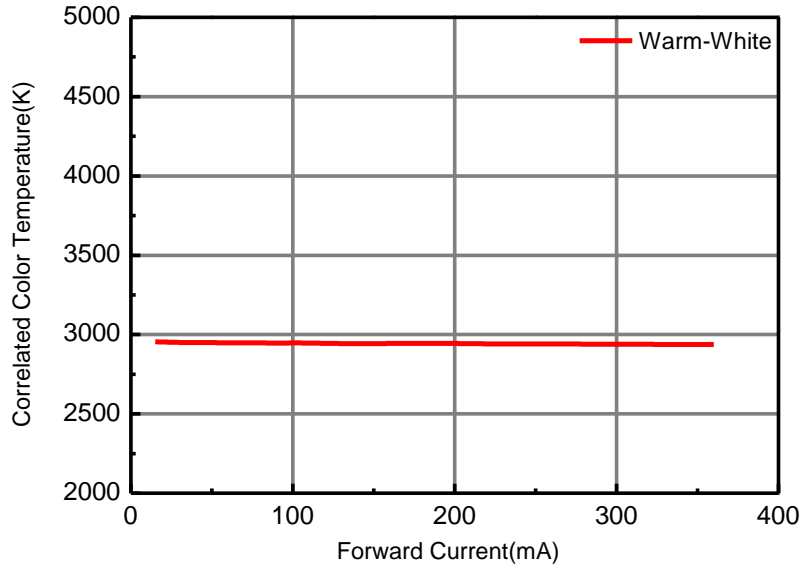

Correlated Color Temperature vs. Substrate Temperature
@ Forward Current = 180mA

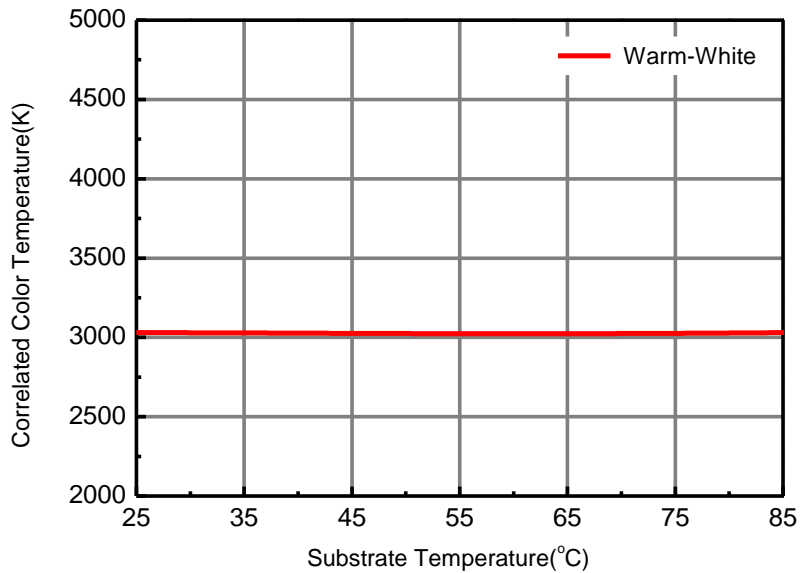

Forward Voltage vs. Substrate Temperature
@ Forward Current = 180mA

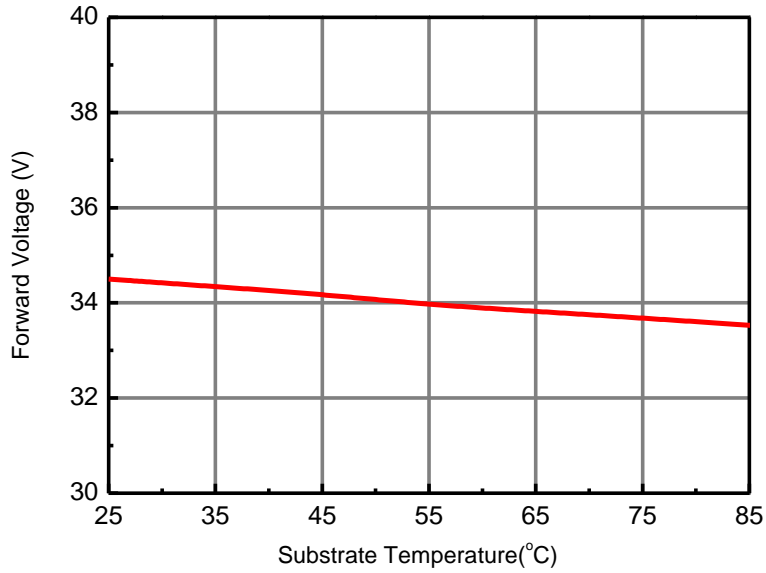

Forward Current Derating Curve
@ Junction Temperature <120°C

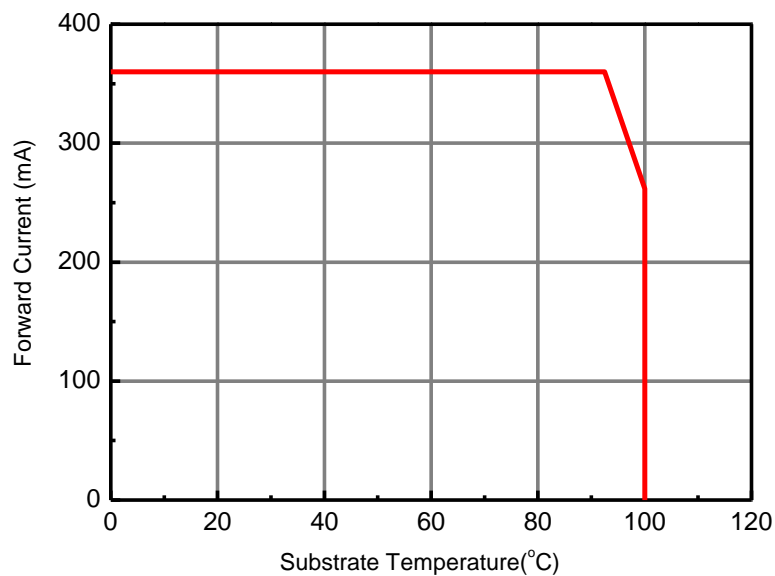

Typical Diagram Characteristics of Radiation Patterns

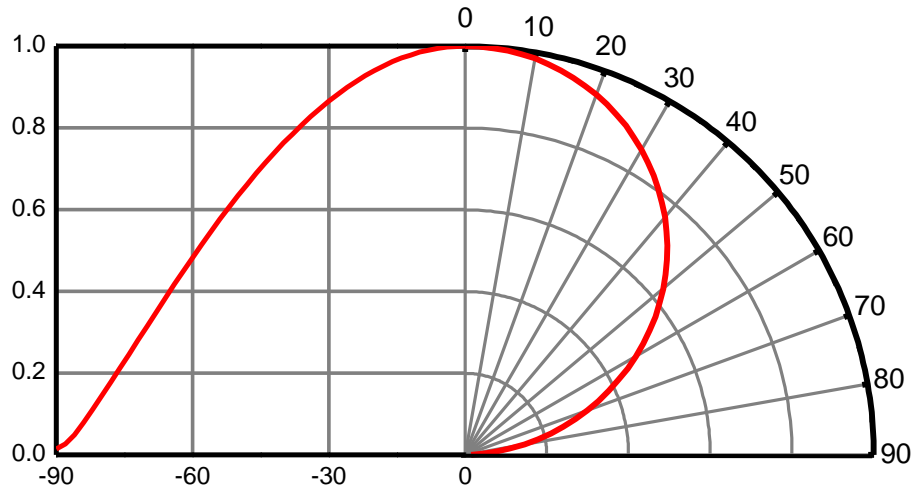

Notes:

1. $2\theta_{1/2}$ is the off axis angle from lamp centerline where the luminous intensity is 1/2 of the peak value.
2. Viewing angle tolerance is $\pm 5^\circ$.

Product Labeling

Label Explanation

CPN: Customer Specification (when required)

P/N : Everlight Americas Production Number

QTY: Packing Quantity

CAT: Luminous Flux (Brightness) Bin

HUE: Color Bin

REF: Forward Voltage Bin

LOT No: Lot Number

MADE IN TAIWAN: Production Place

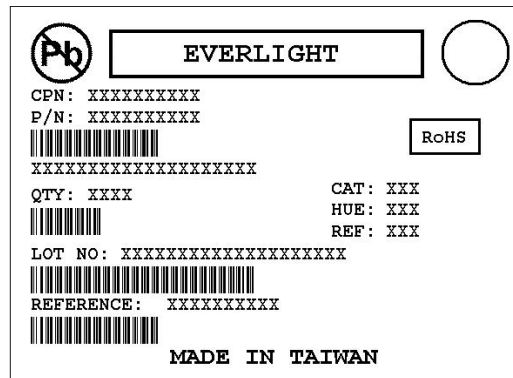

Carrier Tray Specification

Loaded Quantity: 63 PCS Per Tray

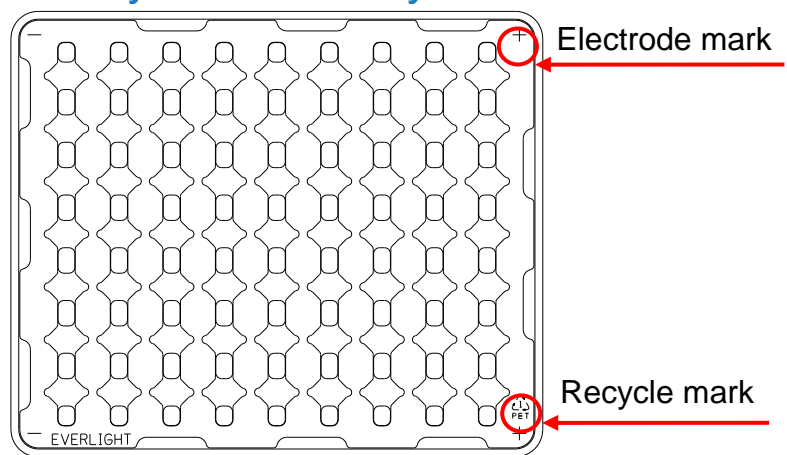
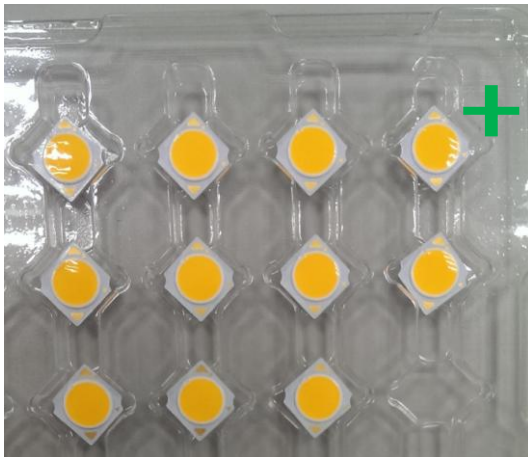

Notes:

1. Dimensions are in millimeters.
2. Tolerances unless mentioned are $\pm 0.1\text{mm}$

LED Direction

- The **Recycle mark** on the LEDs will be toward the **Anode mark** on the carrier tray.

Moisture Resistant Packaging



Outside Carton

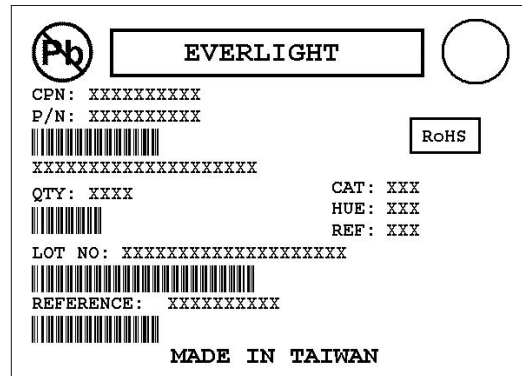
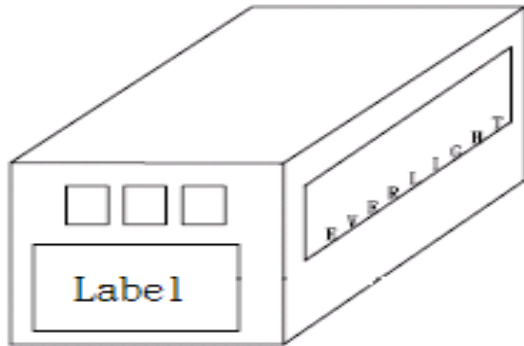

Packaging Quantity

- 63 PCS Per Tray
- 20 Trays Per Outside Carton

Precautions of Use

Over-Current-Proof

- Though the EAHP1313WB0 has a conducted ESD protection mechanism, customers must not use the device in reverse and should apply resistors for extra protection. Otherwise slight voltage shift may cause significant current changes and burn out failure may happen.

Storage Conditions

- Before the package is opened: The LEDs should be stored at 30°C or less and 50%RH or less after being shipped from Everlight Americas and the storage life limit is 6 months. If the LEDs are stored for 6 months or more, they should be stored in a sealed container with a nitrogen atmosphere and moisture absorbent material.
- After opening the package: The LED should be stored under 30°C or less and 30%RH or less. The LED should be used within 168hrs (7days) after opening the package. If unused LEDs remain, it should be stored in moisture proof packages.
- Do not stack assemblies.



Handling

- Do not put mechanical stress on the LED.
- Never touch the optical surface with finger or sharp object. The LED surface could be soiled or damaged, which could affect the optical performance of the LED.
- In low-humidity work environment, please keep handling the LEDs with appropriate ESD grounding.
- It is recommended to handle the LED with powder-less latex gloves.

Manual Handling

- When handling the product, do not apply direct pressure on the optical surface.
- Do not touch the resin with tweezers to avoid scratching or other damage.

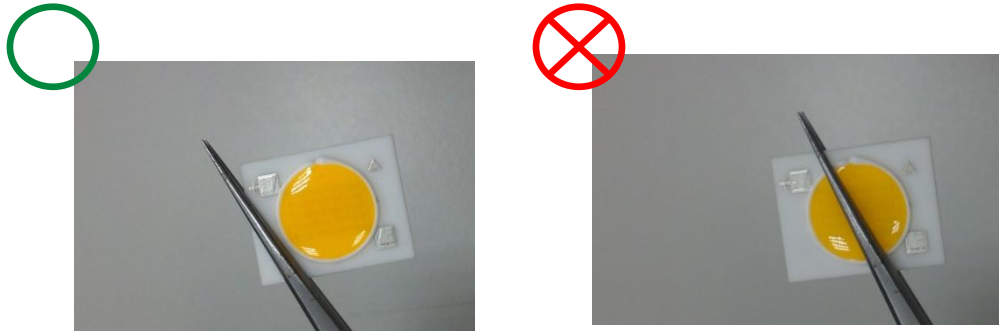

Thermal Management

- Sufficient thermal management must be implemented. Substrate of the positive in temperature must be kept under 105°C at the driving current of 180mA. Otherwise, the junction temperature of die may exceed the limit at high current driving conditions and the LEDs' lifetime may be decrease dramatically.

Revision History

Current version: 07.08.2014
Issue No:
Version: 1

Page	Subjects (major change in previous version)	Date of change