

**MPY634**

## Wide Bandwidth PRECISION ANALOG MULTIPLIER

### FEATURES

- WIDE BANDWIDTH: 10MHz typ
- ±0.5% MAX FOUR-QUADRANT ACCURACY
- INTERNAL WIDE-BANDWIDTH OP AMP
- EASY TO USE
- LOW COST

### APPLICATIONS

- PRECISION ANALOG SIGNAL PROCESSING
- MODULATION AND DEMODULATION
- VOLTAGE-CONTROLLED AMPLIFIERS
- VIDEO SIGNAL PROCESSING
- VOLTAGE-CONTROLLED FILTERS AND OSCILLATORS

### DESCRIPTION

The MPY634 is a wide bandwidth, high accuracy, four-quadrant analog multiplier. Its accurately laser-trimmed multiplier characteristics make it easy to use in a wide variety of applications with a minimum of external parts, often eliminating all external trimming. Its differential X, Y, and Z inputs allow configuration as a multiplier, squarer, divider, square-rooter, and other functions while maintaining high accuracy.

The wide bandwidth of this new design allows signal processing at IF, RF, and video frequencies. The internal output amplifier of the MPY634 reduces design complexity compared to other high frequency multipliers and balanced modulator circuits. It is capable of performing frequency mixing, balanced modulation, and demodulation with excellent carrier rejection.

An accurate internal voltage reference provides precise setting of the scale factor. The differential Z input allows user-selected scale factors from 0.1 to 10 using external feedback resistors.

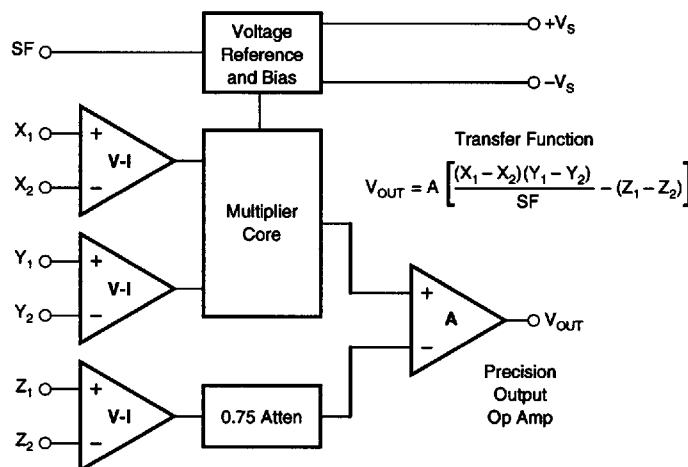

International Airport Industrial Park • Mailing Address: PO Box 11400 • Tucson, AZ 85734 • Street Address: 6730 S. Tucson Blvd. • Tucson, AZ 85706  
Tel: (520) 746-1111 • Twx: 910-952-1111 • Cable: BBRCORP • Telex: 066-6491 • FAX: (520) 889-1510 • Immediate Product Info: (800) 548-6132

# SPECIFICATIONS

## ELECTRICAL

At  $T_A = +25^\circ\text{C}$  and  $V_S = \pm 15\text{VDC}$ , unless otherwise noted.

MODEL	MPY634KP/KU			MPY634AM			MPY634BM			MPY634SM			UNITS
	MIN	TYP	MAX	MIN	TYP	MAX	MIN	TYP	MAX	MIN	TYP	MAX	
<b>MULTIPLIER PERFORMANCE</b>													
Transfer Function		*		$\frac{(X_1 - X_2)(Y_1 - Y_2)}{10V} + Z_2$				*			*		
Total Error <sup>(1)</sup> ( $-10V \leq X, Y \leq +10V$ )			$\pm 2.0$			$\pm 1.0$			$\pm 0.5$			*	%
$T_A = \text{min to max}$		$\pm 2.5$			$\pm 1.5$			$\pm 1.0$				$\pm 2.0$	%
Total Error vs Temperature		$\pm 0.03$			$\pm 0.022$			$\pm 0.015$				$\pm 0.02$	%/°C
Scale Factor Error (SF = 10.000V Nominal) <sup>(2)</sup>		$\pm 0.25$			$\pm 0.1$			*			*		%
Temperature Coefficient of Scaling Voltage		$\pm 0.02$			$\pm 0.01$			$\pm 0.01$			*		%/°C
Supply Rejection ( $\pm 15V \pm 1V$ )		*			$\pm 0.01$			*			*		%
Nonlinearity													
X ( $X = 20Vp-p, Y = 10V$ )		*			$\pm 0.4$			0.2	$\pm 0.3$		*		%
Y ( $Y = 20Vp-p, X = 10V$ )		*			$\pm 0.01$			*	$\pm 0.1$		*		%
Feedthrough <sup>(3)</sup>													
X (Y Nulled, $X = 20Vp-p, 50\text{Hz}$ )		*			$\pm 0.3$			$\pm 0.15$	$\pm 0.3$		*		%
Y (X Nulled, $Y = 20Vp-p, 50\text{Hz}$ )		*			$\pm 0.01$			*	$\pm 0.1$		*		%
Both Inputs (500kHz, 1Vrms)													
Unnulled	40 <sup>(4)</sup>	50		45	55		*	60		*	*		dB
Nulled	55 <sup>(4)</sup>	60		55	65		60	70		*	*		dB
Output Offset Voltage		$\pm 50$	$\pm 100$		$\pm 5$	$\pm 30$		*			*	*	mV
Output Offset Voltage Drift		*			$\pm 200$			$\pm 100$	$\pm 15$		*	*	$\mu\text{V}/^\circ\text{C}$
<b>DYNAMICS</b>													
Small Signal BW, ( $V_{\text{OUT}} = 0.1\text{Vrms}$ )	6 <sup>(4)</sup>	*		8	10		*	*		6	*		MHz
1% Amplitude Error ( $C_{\text{LOAD}} = 1000\text{pF}$ )		*			100			*			*		kHz
Slew Rate ( $V_{\text{OUT}} = 20Vp-p$ )		*			20			*			*		V/ $\mu\text{s}$
Settling Time (to 1%, $\Delta V_{\text{OUT}} = 20V$ )		*			2			*			*		$\mu\text{s}$
<b>NOISE</b>													
Noise Spectral Density: SF = 10V		*			0.8			*			*		$\mu\text{V}/\sqrt{\text{Hz}}$
Wideband Noise: f = 10Hz to 5MHz		*			1			*			*		mVrms
f = 10Hz to 10kHz		*			90			*			*		$\mu\text{Vrms}$
<b>OUTPUT</b>													
Output Voltage Swing	*			$\pm 11$			*			*			V
Output Impedance ( $f \leq 1\text{kHz}$ )		*			0.1			*			*		$\Omega$
Output Short Circuit Current ( $R_L = 0, T_A = \text{min to max}$ )		*			30			*			*		mA
Amplifier Open Loop Gain (f = 50Hz)		*			85			*			*		dB
<b>INPUT AMPLIFIERS (X, Y and Z)</b>													
Input Voltage Range													
Differential $V_{\text{IN}}$ ( $V_{\text{CM}} = 0$ )		*			$\pm 12$			*			*		V
Common-Mode $V_{\text{IN}}$ ( $V_{\text{DIFF}} = 0$ ) (see Typical Performance Curves)		*			$\pm 10$			*			*		V
Offset Voltage X, Y		$\pm 25$	$\pm 100$		$\pm 5$	$\pm 20$		$\pm 2$	$\pm 10$		*	*	mV
Offset Voltage Drift X, Y		200			100			50			*	*	$\mu\text{V}/^\circ\text{C}$
Offset Voltage Z		$\pm 25$	$\pm 100$		$\pm 5$	$\pm 30$		$\pm 2$	$\pm 15$		*	*	mV
Offset Voltage Drift Z		*			200			100			*	500	$\mu\text{V}/^\circ\text{C}$
CMRR	*	*		60	80		70	90		*	*		dB
Bias Current		*	*		0.8	2.0		*	*		*	*	$\mu\text{A}$
Offset Current		*			0.1			*			*	2.0	$\mu\text{A}$
Differential Resistance		*			10			*			*		M $\Omega$
<b>DIVIDER PERFORMANCE</b>													
Transfer Function ( $X_1 > X_2$ )		*		$10V \frac{(Z_2 - Z_1)}{(X_1 - X_2)} + Y_1$				*			*		
Total Error <sup>(1)</sup> untrimmed ( $X = 10V, -10V \leq Z \leq +10V$ )		1.5			$\pm 0.75$			$\pm 0.35$			$\pm 0.75$		%
( $X = 1V, -1V \leq Z \leq +1V$ )		4.0			$\pm 2.0$			$\pm 1.0$			*		%
( $0.1V \leq X \leq 10V, -10V \leq Z \leq 10V$ )		5.0			$\pm 2.5$			$\pm 1.0$			*		%
<b>SQUARE PERFORMANCE</b>													
Transfer Function		*		$\frac{(X_1 - X_2)^2}{10V} + Z_2$				*			*		
Total Error ( $-10V \leq X \leq 10V$ )		$\pm 1.2$			$\pm 0.6$			$\pm 0.3$			*		%

# SPECIFICATIONS (CONT)

## ELECTRICAL

At  $T_A = +25^\circ\text{C}$  and  $V_S = \pm 15\text{VDC}$ , unless otherwise noted.

MODEL	MPY634KP/KU			MPY634AM			MPY634BM			MPY634SM			UNITS
	MIN	TYP	MAX	MIN	TYP	MAX	MIN	TYP	MAX	MIN	TYP	MAX	
<b>SQUARE-ROOTER PERFORMANCE</b> Transfer Function ( $Z_1 \leq Z_2$ ) Total Error <sup>(1)</sup> ( $1\text{V} \leq Z \leq 10\text{V}$ )		*		$\sqrt{10\text{V}(Z_2 - Z_1)} + X_2$				*			*		%
<b>POWER SUPPLY</b> Supply Voltage: Rated Performance Operating Supply Current, Quiescent	*	*	*	$\pm 8$	$\pm 15$	$\pm 18$ 6	*	*	*	*	*	$\pm 20$ *	VDC VDC mA
<b>TEMPERATURE RANGE</b> Specification Storage	<sup>(5)</sup> -40		<sup>(5)</sup> +85	-25 -65		+85 +150	*	*	*	-55 *		+125 *	$^\circ\text{C}$ $^\circ\text{C}$

\* Specification same as for MPY634AM.

NOTES: (1) Figures given are percent of full scale,  $\pm 10\text{V}$  (i.e.,  $0.01\% = 1\text{mV}$ ). (2) May be reduced to 3V using external resistor between  $-V_S$  and SF. (3) Irreducible component due to nonlinearity; excludes effect of offsets. (4) KP grade only. (5) KP grade only.  $0^\circ\text{C}$  to  $+70^\circ\text{C}$  for KU grade.

## PIN CONFIGURATIONS

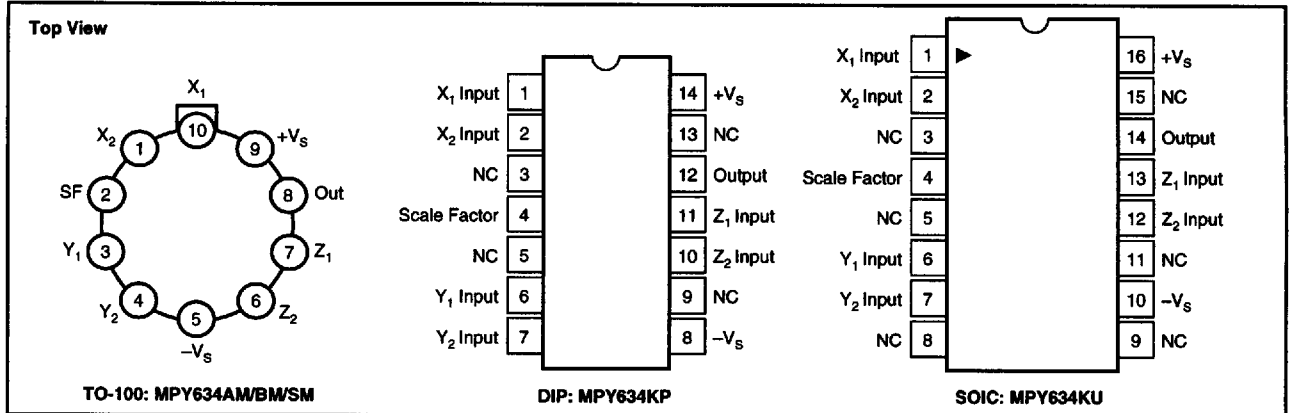

## ABSOLUTE MAXIMUM RATINGS

PARAMETER	MPY634AM/BM	MPY634KP/KU	MPY634SM
Power Supply Voltage	$\pm 18$	*	$\pm 20$
Power Dissipation	500mW	*	*
Output Short-Circuit to Ground	Indefinite	*	*
Input Voltage (all X, Y and Z)	$\pm V_S$	*	*
Temperature Range:			
Operating	$-25^\circ\text{C}/+85^\circ\text{C}$	*	$-55^\circ\text{C}/+125^\circ\text{C}$
Storage	$-65^\circ\text{C}/+150^\circ\text{C}$	$-40^\circ\text{C}/+85^\circ\text{C}$	*
Lead Temperature (soldering, 10s)	+300 $^\circ\text{C}$	*	*
SOIC 'KU' Package		+260 $^\circ\text{C}$	

\* Specification same as for MPY634AM/BM.

## ORDERING INFORMATION

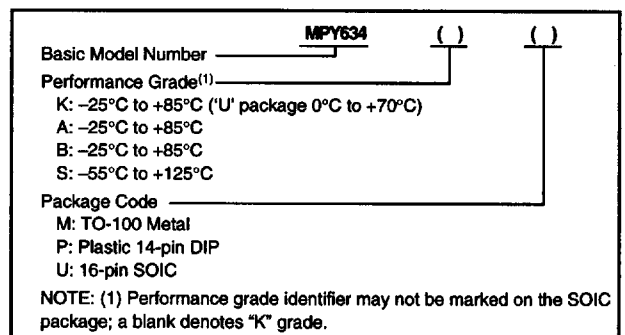

## PACKAGE INFORMATION

MODEL	PACKAGE	PACKAGE DRAWING NUMBER <sup>(1)</sup>
MPY634KP	14-Pin PDIP	010
MPY634KU	16-Pin SOIC	211
MPY634AM	TO-100	007
MPY634BM	TO-100	007
MPY634SM	TO-100	007

NOTE: (1) For detailed drawing and dimension table, please see end of data sheet, or Appendix D of Burr-Brown IC Data Book.

# TYPICAL PERFORMANCE CURVES

$T_A = +25^\circ\text{C}$ ,  $V_S = \pm 15\text{VDC}$ , unless otherwise noted.

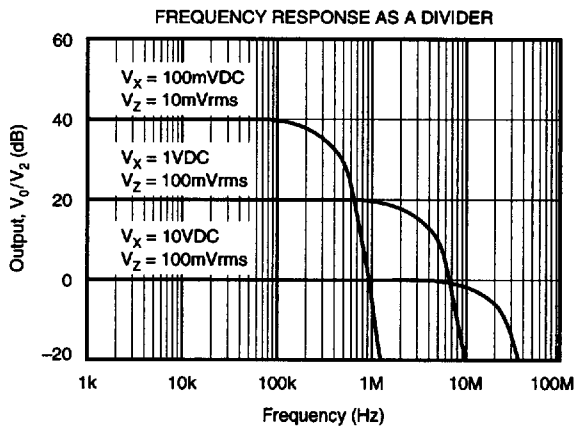
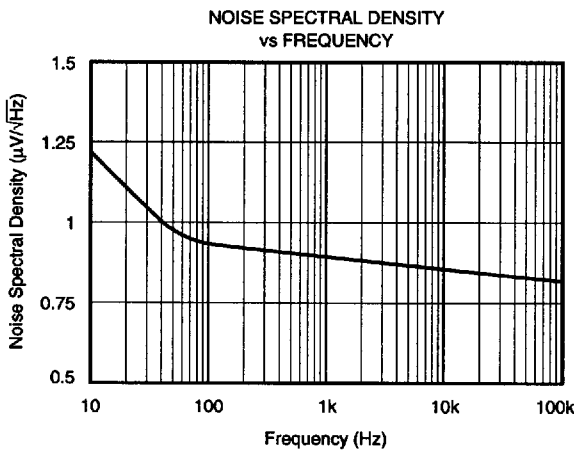
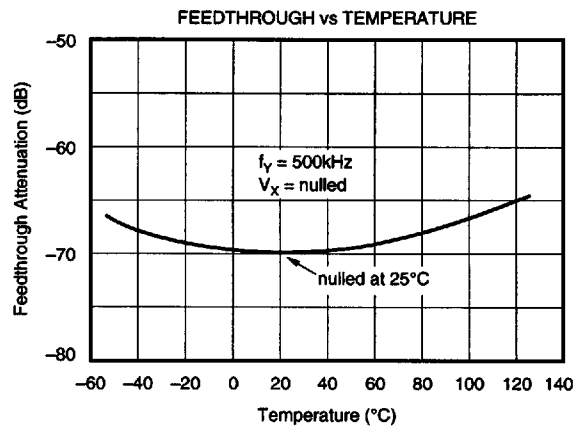
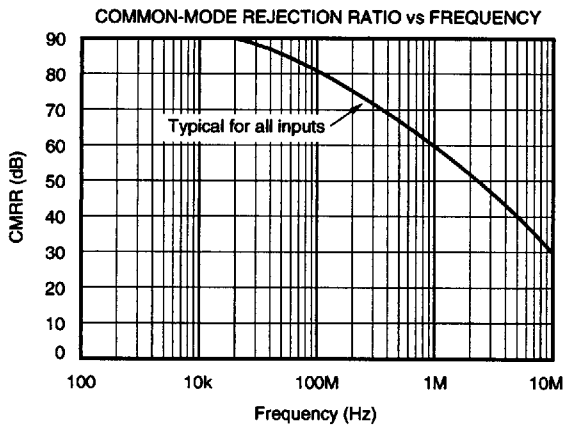
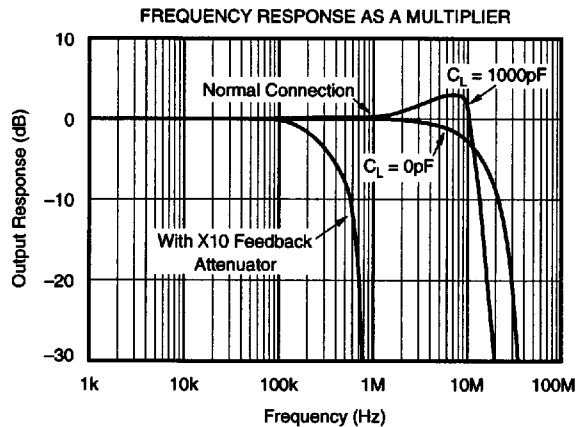
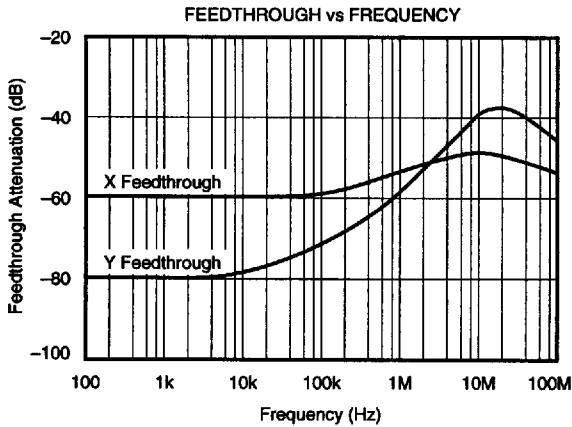

The information provided herein is believed to be reliable; however, BURR-BROWN assumes no responsibility for inaccuracies or omissions. BURR-BROWN assumes no responsibility for the use of this information, and all use of such information shall be entirely at the user's own risk. Prices and specifications are subject to change without notice. No patent rights or licenses to any of the circuits described herein are implied or granted to any third party. BURR-BROWN does not authorize or warrant any BURR-BROWN product for use in life support devices and/or systems.

# TYPICAL PERFORMANCE CURVES (CONT)

$T_A = +25^\circ\text{C}$ ,  $V_S = \pm 15\text{VDC}$ , unless otherwise noted.

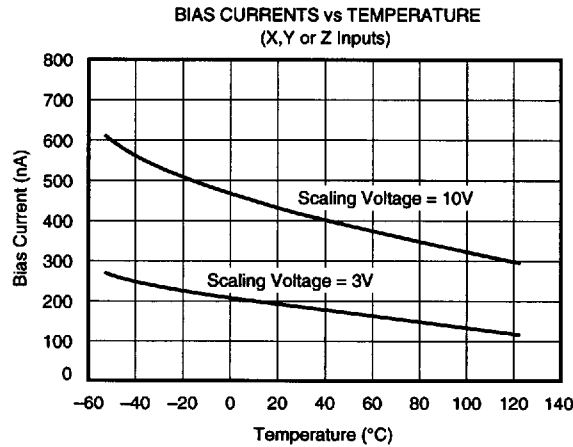
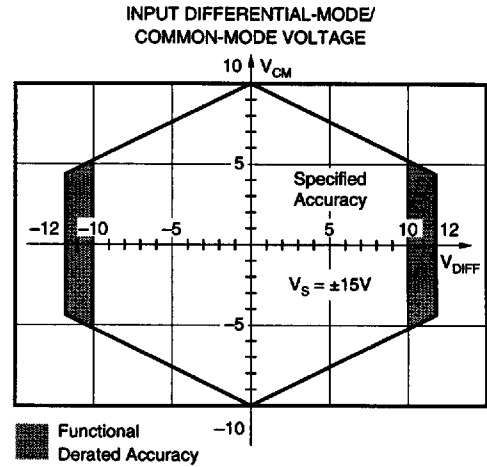
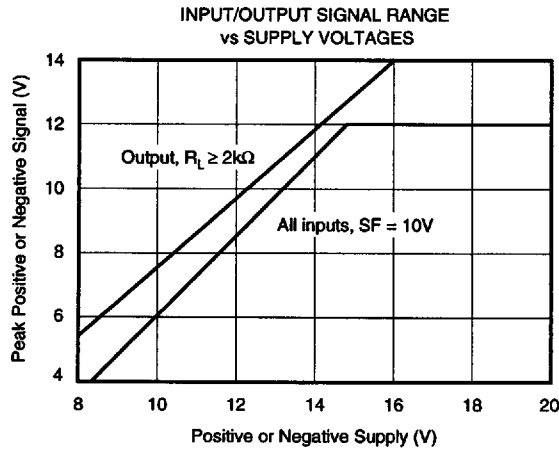

## THEORY OF OPERATION

The transfer function for the MPY634 is:

$$V_{OUT} = A \left[ \frac{(X_1 - X_2)(Y_1 - Y_2)}{SF} - (Z_1 - Z_2) \right]$$

where:

A = open-loop gain of the output amplifier (typically 85dB at DC).

SF = Scale Factor. Laser-trimmed to 10V but adjustable over a 3V to 10V range using external resistors.

X, Y, Z are input voltages. Full-scale input voltage is equal to the selected SF. (Max input voltage =  $\pm 1.25$  SF).

An intuitive understanding of transfer function can be gained by analogy to the op amp. By assuming that the open-loop gain, A, of the output operational amplifier is infinite,

inspection of the transfer function reveals that any  $V_{OUT}$  can be created with an infinitesimally small quantity within the brackets. Then, an application circuit can be analyzed by assigning circuit voltages for all X, Y and Z inputs and setting the bracketed quantity equal to zero. For example, the basic multiplier connection in Figure 1,  $Z_1 = V_{OUT}$  and  $Z_2 = 0$ . The quantity within the brackets then reduces to:

$$\frac{(X_1 - X_2)(Y_1 - Y_2)}{SF} - (V_{OUT} - 0) = 0$$

This approach leads to a simple relationship which can be solved for  $V_{OUT}$  to provide the closed-loop transfer function.

The scale factor is accurately factory adjusted to 10V and is typically accurate to within 0.1% or less. The scale factor may be adjusted by connecting a resistor or potentiometer between pin SF and the  $-V_S$  power supply. The value of the external resistor can be approximated by:

$$R_{SF} = 5.4k\Omega \left( \frac{SF}{10 - SF} \right)$$

Internal device tolerances make this relationship accurate to within approximately 25%. Some applications can benefit from reduction of the SF by this technique. The reduced input bias current, noise, and drift achieved by this technique can be likened to operating the input circuitry in a higher gain, thus reducing output contributions to these effects. Adjustment of the scale factor does not affect bandwidth.

The MPY634 is fully characterized at  $V_S = \pm 15V$  but operation is possible down to  $\pm 8V$  with an attendant reduction of input and output range capability. Operation at voltages greater than  $\pm 15V$  allows greater output swing to be achieved by using an output feedback attenuator (Figure 1).

As with any wide bandwidth circuit, the power supplies should be bypassed with high frequency ceramic capacitors. These capacitors should be located as near as practical to the power supply connections of the MPY634. Improper bypassing can lead to instability, overshoot, and ringing in the output.

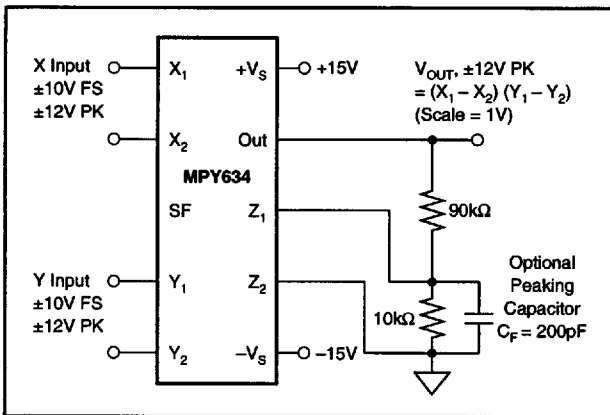

FIGURE 1. Connections for Scale-Factor of Unity.

### BASIC MULTIPLIER CONNECTION

Figure 2 shows the basic connection as a multiplier. Accuracy is fully specified without any additional user-trimming circuitry. Some applications can benefit from trimming of one or more of the inputs. The fully differential inputs facilitate referencing the input quantities to the source voltage common terminal for maximum accuracy. They also allow use of simple offset voltage trimming circuitry as shown on the X input.

The differential Z input allows an offset to be summed in  $V_{OUT}$ . In basic multiplier operation, the  $Z_2$  input serves as the output voltage ground reference and should be connected to the ground of the driven system for maximum accuracy.

A method of changing (lowering) SF by connecting to the SF pin was discussed previously. Figure 1 shows an alternative method of changing the effective SF of the overall circuit by using an attenuator in the feedback connection to  $Z_1$ . This method puts the output amplifier in a higher gain and is thus accompanied by a reduction in bandwidth and an

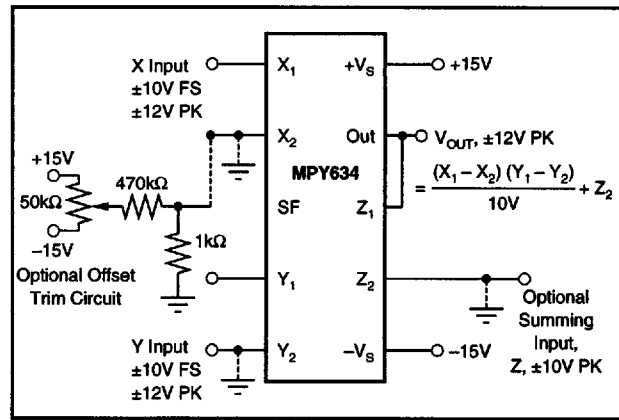

FIGURE 2. Basic Multiplier Connection.

increase in output offset voltage. The larger output offset may be reduced by applying a trimming voltage to the high impedance input,  $Z_2$ .

The flexibility of the differential Z inputs allows direct conversion of the output quantity to a current. Figure 3 shows the output voltage differentially-sensed across a series resistor forcing an output-controlled current. Addition of a capacitor load then creates a time integration function useful in a variety of applications such as power computation.

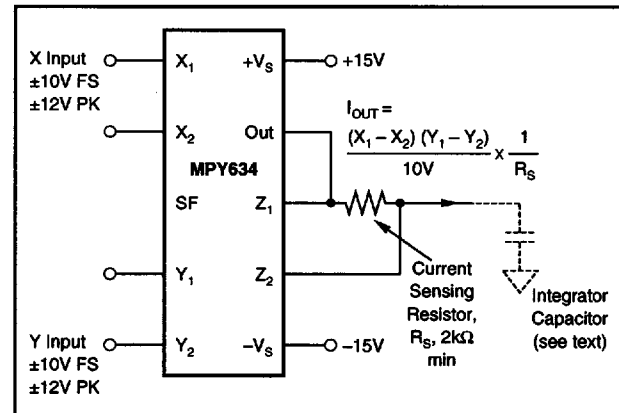

FIGURE 3. Conversion of Output to Current.

### SQUARER CIRCUIT (FREQUENCY DOUBLER)

Squarer, or frequency doubler, operation is achieved by paralleling the X and Y inputs of the standard multiplier circuit. Inverted output can be achieved by reversing the differential input terminals of either the X or Y input. Accuracy in the squaring mode is typically a factor of two better than the specified multiplier mode with maximum error occurring with small (less than 1V) inputs. Better accuracy can be achieved for small input voltage levels by reducing the scale factor, SF.

### DIVIDER OPERATION

The MPY634 can be configured as a divider as shown in Figure 4. High impedance differential inputs for the numerator and denominator are achieved at the Z and X inputs,

respectively. Feedback is applied to the  $Y_2$  input, and  $Y_1$  is normally referenced to output ground. Alternatively, as the transfer function implies, an input applied to  $Y_1$  can be summed directly into  $V_{OUT}$ . Since the feedback connection is made to a multiplying input, the effective gain of the output op amp varies as a function of the denominator input voltage. Therefore, the bandwidth of the divider function is proportional to the denominator voltage (see Typical Performance Curves).

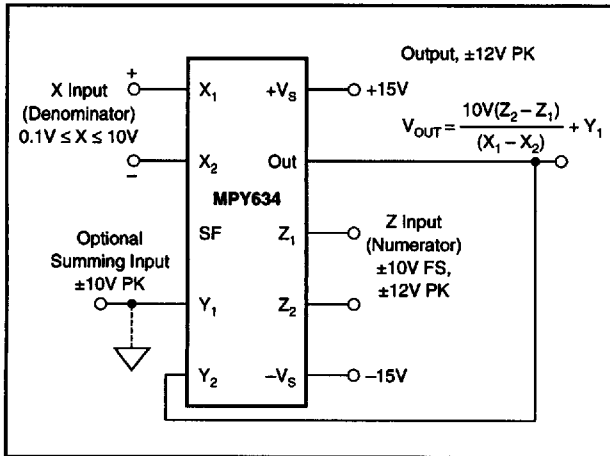

FIGURE 4. Basic Divider Connection.

Accuracy of the divider mode typically ranges from 1.0% to 2.5% for a 10 to 1 denominator range depending on device grade. Accuracy is primarily limited by input offset voltages and can be significantly improved by trimming the offset of the X input. A trim voltage of  $\pm 3.5\text{mV}$  applied to the "low side" X input ( $X_2$  for positive input voltages on  $X_1$ ) can produce similar accuracies over 100 to 1 denominator range. To trim, apply a signal which varies from 100mV to 10V at a low frequency (less than 500Hz). An offset sine wave or ramp is suitable. Since the ratio of the quantities should be constant, the ideal output would be a constant 10V. Using AC coupling on an oscilloscope, adjust the offset control for minimum output voltage variation.

### SQUARE-ROOTER

A square-roooter connection is shown in Figure 5. Input voltage is limited to one polarity (positive for the connection shown). The diode prevents circuit latch-up should the input go negative. The circuit can be configured for negative input and positive output by reversing the polarity of both the X and Y inputs. The output polarity can be reversed by reversing the diode and X input polarity. A load resistance of approximately  $10\text{k}\Omega$  must be provided. Trimming for improved accuracy would be accomplished at the Z input.

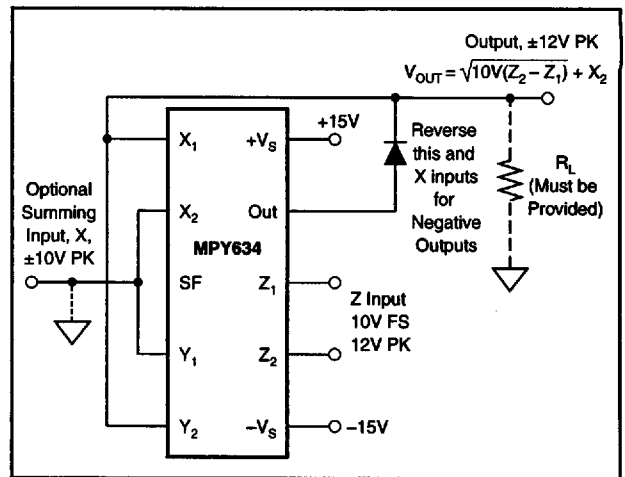

FIGURE 5. Square-Rooter Connection.

## APPLICATIONS

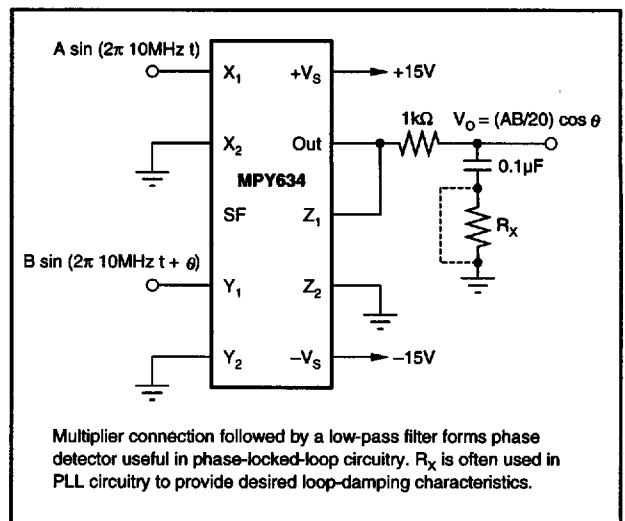

FIGURE 6. Phase Detector.

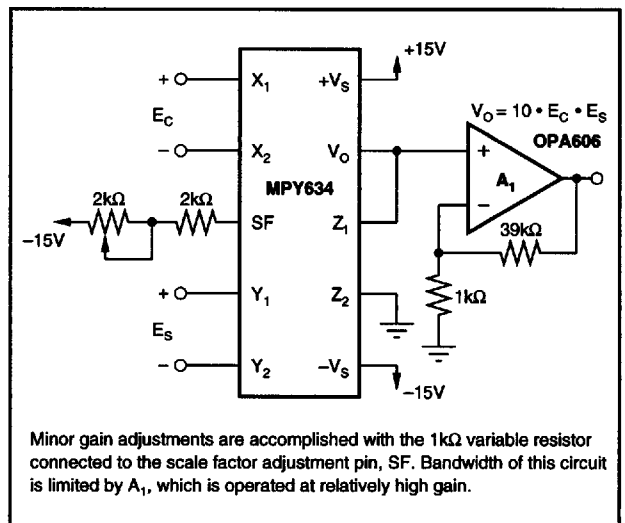

FIGURE 7. Voltage-Controlled Amplifier.

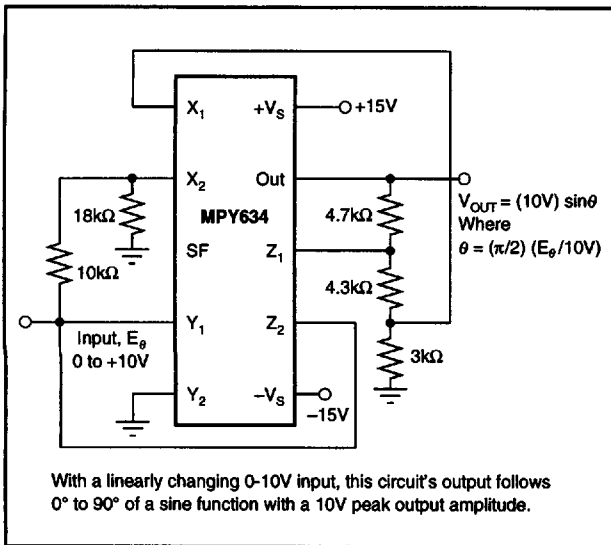

FIGURE 8. Sine-Function Generator.

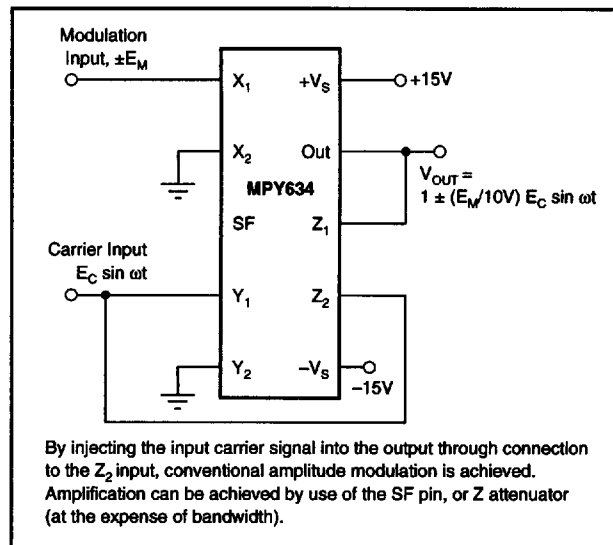

FIGURE 9. Linear AM Modulator.

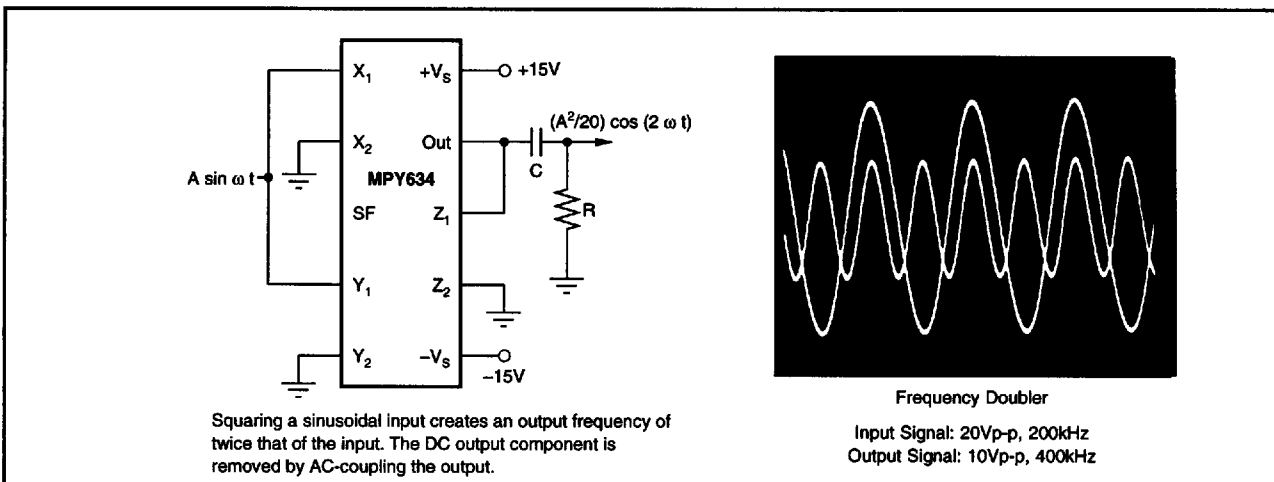

FIGURE 10. Frequency Doubler.

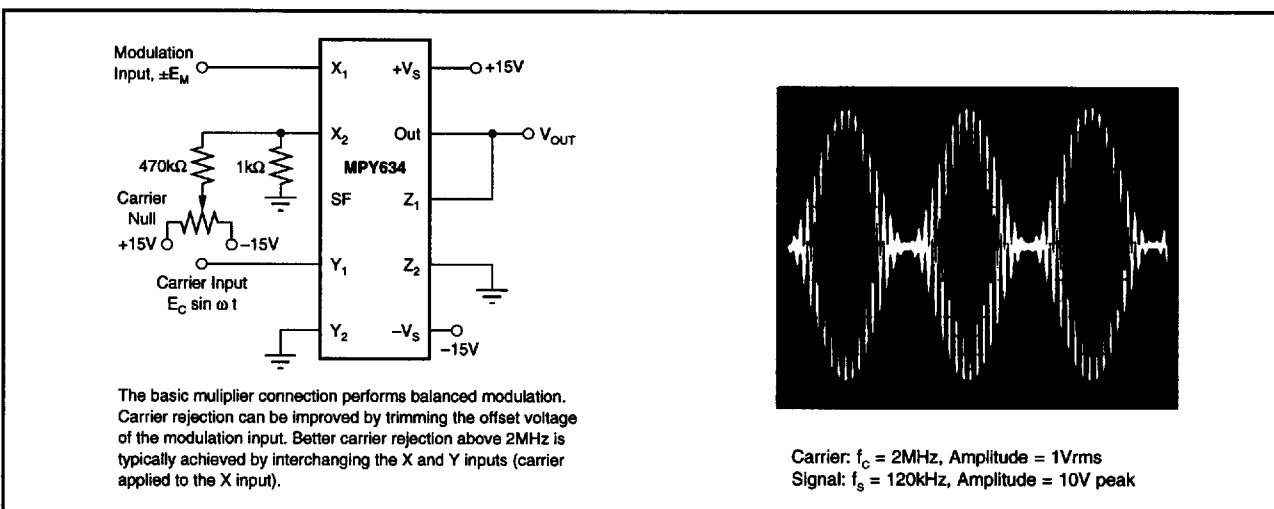
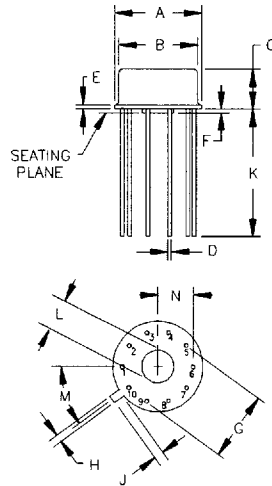

FIGURE 11. Balanced Modulator.



Package Number 007 - TO-100 Package



DIM	INCHES		MILLIMETERS		NOTE	DIM	INCHES		MILLIMETERS		NOTE
	MIN.	MAX.	MIN.	MAX.			MIN.	MAX.	MIN.	MAX.	
A	.335	.370	8.51	9.40							
B	.305	.335	7.75	8.51							
C	.165	.185	4.19	4.70							
D	.016	.021	0.41	0.53							
E	.010	.040	0.25	1.02							
F	.010	.040	0.25	1.02							
G	.230	BASIC	5.84	BASIC							
H	.028	.034	0.71	0.86							
J	.029	.045	0.74	1.14							
K	.500	---	12.70	---							
L	.120	.160	3.05	4.06							
M	.36	BASIC	36	BASIC							
N	.110	.120	2.79	3.05							

NOTES:

- LEADS IN TRUE POSITION WITHIN .010" (0.25mm) R @ MMC AT SEATING PLANE.
- PIN NUMBERS SHOWN FOR REFERENCE ONLY. NUMBERS MAY NOT BE MARKED ON PACKAGE.

PACKAGE NUMBER: Z2007      REV.: A  
 JEDEC NUMBER: UNKNOWN



PACKAGE DRAWING

1731365 0027732 801

Package Number 010 - 14-Pin Plastic, Single-Wide DIP

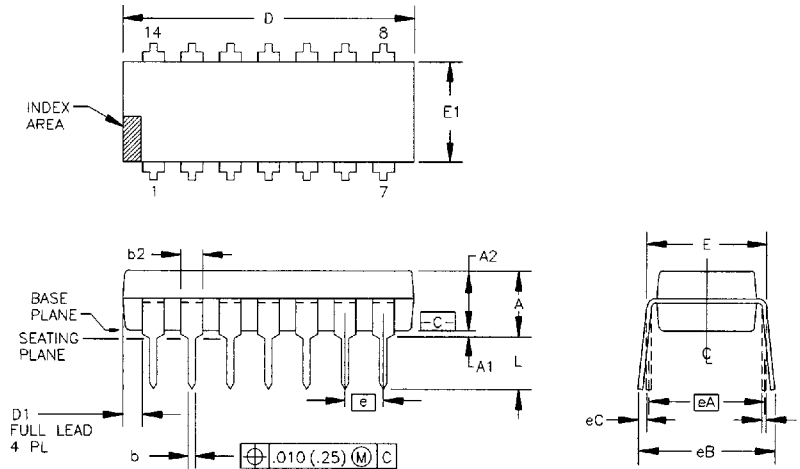

DIM	INCHES		MILLIMETERS		N	E	DIM	INCHES		MILLIMETERS		N	E
	MIN.	MAX.	MIN.	MAX.				MIN.	MAX.	MIN.	MAX.		
A	--	.210	--	5.33	3		L	.115	.150	2.92	3.81	3	
A1	.015	--	0.38	--	3		N		14		14	7	
A2	.115	.195	2.92	4.95									
b	.014	.022	0.36	0.56									
b2	.045	.070	1.14	1.78	9								
c	.008	.014	0.20	0.36									
D	.735	.775	18.67	19.69	4								
D1	.005	--	0.13	--	4								
E	.300	.325	7.62	8.26	5								
E1	.240	.280	6.10	7.11	4								
e	.100	BASIC	2.54	BASIC									
eA	.300	BASIC	7.63	BASIC	5								
eB	--	.430	--	10.92	6								
eC	.000	.060	0.00	1.52	6								

NOTES:

1. ALL DIMENSIONS ARE IN INCHES.
2. DIMENSIONING AND TOLERANCING PER ANSI Y14.5M-1982.
3. DIMENSIONS A, A1, AND L ARE MEASURED WITH THE PACKAGE SEATED IN JEDEC SEATING PLANE GAUGE GS-3.
4. D, D1, AND E1 DIMENSIONS DO NOT INCLUDE MOLD FLASH OR PROTRUSIONS. MOLD FLASH OR PROTRUSIONS SHALL NOT EXCEED .010 (0.25mm).
5. E AND eA MEASURED WITH THE LEADS CONSTRAINED TO BE PERPENDICULAR TO DATUM  $\text{--C--}$ .
6. eB AND eC ARE MEASURED AT THE LEAD TIPS WITH THE LEADS UNCONSTRAINED.
7. N IS THE MAXIMUM OF TERMINAL POSITIONS.

8. POINTED OR ROUNDED LEAD TIPS ARE PREFERRED TO EASE INSERTION.
9. b2 MAXIMUM DIMENSION DOES NOT INCLUDE DAMBAR PROTRUSIONS. DAMBAR PROTRUSIONS SHALL NOT EXCEED .010 (0.25mm).
10. DISTANCE BETWEEN LEADS INCLUDING DAMBAR PROTRUSIONS TO BE .005 (0.13mm) MINIMUM.
11. A VISUAL INDEX FEATURE MUST BE LOCATED WITHIN THE CROSS-HATCHED AREA.
12. FOR AUTOMATIC INSERTION, ANY RAISED IRREGULARITY ON THE TOP SURFACE (STEP, MESA, ETC.) SHALL BE SYMMETRICAL ABOUT THE LATERAL AND LONGITUDINAL PACKAGE CENTERLINES.

PACKAGE NUMBER: ZZ010      REV.: G  
 JEDEC NUMBER:      MS-001-AA

Package Number 211 - 16-Lead SOIC, .300 Wide

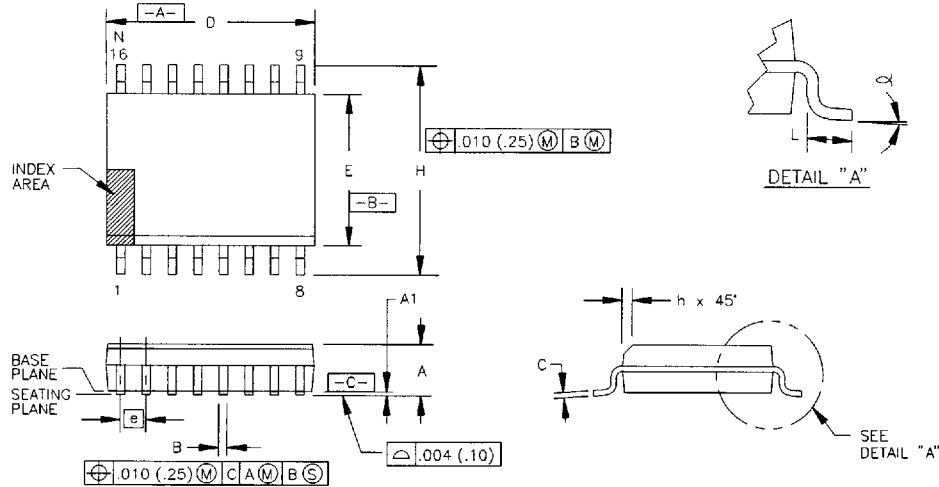

DIM	INCHES		MILLIMETERS		NOTE	DIM	INCHES		MILLIMETERS		NOTE
	MIN.	MAX.	MIN.	MAX.			MIN.	MAX.	MIN.	MAX.	
A	.0926	.1043	2.35	2.65							
A1	.004	.0118	0.10	0.30							
B	.013	.020	0.33	0.51	7						
C	.0091	.0125	0.23	0.32							
D	.3977	4.133	10.10	10.50	2						
E	.2914	.2992	7.40	7.60	3						
e	.050	BASIC	1.27	BASIC							
H	.394	.419	10.00	10.65							
h	.010	.029	0.25	0.75	4						
L	.016	.050	0.40	1.27	5						
N	16		16		6						
alpha	0°	8°	0°	8°							

NOTES:

- DIMENSIONING AND TOLERANCING PER ANSI Y14.5M-1982.
- DIMENSION D DOES NOT INCLUDE MOLD FLASH, PROTRUSIONS OR GATE BURRS. MOLD FLASH, PROTRUSIONS AND GATE BURRS SHALL NOT EXCEED .006 IN. (0.15 mm) PER SIDE.
- DIMENSION E DOES NOT INCLUDE INTER-LEAD FLASH OR PROTRUSIONS. INTER-LEAD FLASH AND PROTRUSIONS SHALL NOT EXCEED .010 IN. (0.25 mm) PER SIDE.
- THE CHAMFER ON THE BODY IS OPTIONAL. IF IT IS NOT PRESENT,

- A VISUAL INDEX FEATURE MUST BE LOCATED WITHIN THE CROSS-HATCHED AREA.
- L IS THE LENGTH OF TERMINAL FOR SOLDERING TO A SUBSTRATE.
- N IS THE NUMBER OF TERMINAL POSITIONS.
- THE LEAD WIDTH B, AS MEASURED .014 IN. (0.36 mm) OR GREATER ABOVE THE SEATING PLANE, SHALL NOT EXCEED A MAXIMUM VALUE OF .024 IN. (0.61 mm).
- LEAD TO LEAD COPLANARITY SHALL BE LESS THAN .004 IN. (0.10 mm) FROM SEATING PLANE.

PACKAGE NUMBER: ZZ211 | REV.: F  
JEDEC NUMBER: MS-013-AA



PACKAGE DRAWING

1731365 0027734 684