MSM7512B

1200 bps Half Duplex FSK Modem – ITU-T V.23

GENERAL DESCRIPTION

The MSM7512B is useful for the ITU-T V.23 modem, for examples, low cost built-in modems, telecontrol systems, home security systems, etc.

The family version, MSM7510 for ITU-T V.21, will be available following this device.

Oki has been mass-producing and delivering the MSM6926 and 6927 for a long time, but these devices need two power supplies, +5 V for digital and +12 V for analog.

New generation devices, MSM7510/7512B, work with single rail +3 V to +5 V and low power consumption.

FEATURES

- Conforms to ITU-T V.23, 1200 bps Half Duplex
- Conforms to ITU-T V.23, 75 bps transmitter
- Single Power Supply: +3 V to +5 V
- Low Power Consumption
 - Operating Mode: 25 mW Typ.
 - Power Down Mode: 0.1 mW Max.
- Line Hybrid Circuit on Chip
- Line Direct Drive Capability of Analog Output
- 3.579545 MHz Crystal Oscillator
- Digital Interface: TTL
- Package options:

16-pin plastic DIP	(DIP16-P-300-2.54)	(Product name: MSM7512BRS)
24-pin plastic SOP	(SOP24-P-430-1.27-K)	(Product name: MSM7512BGS-K)

BLOCK DIAGRAM

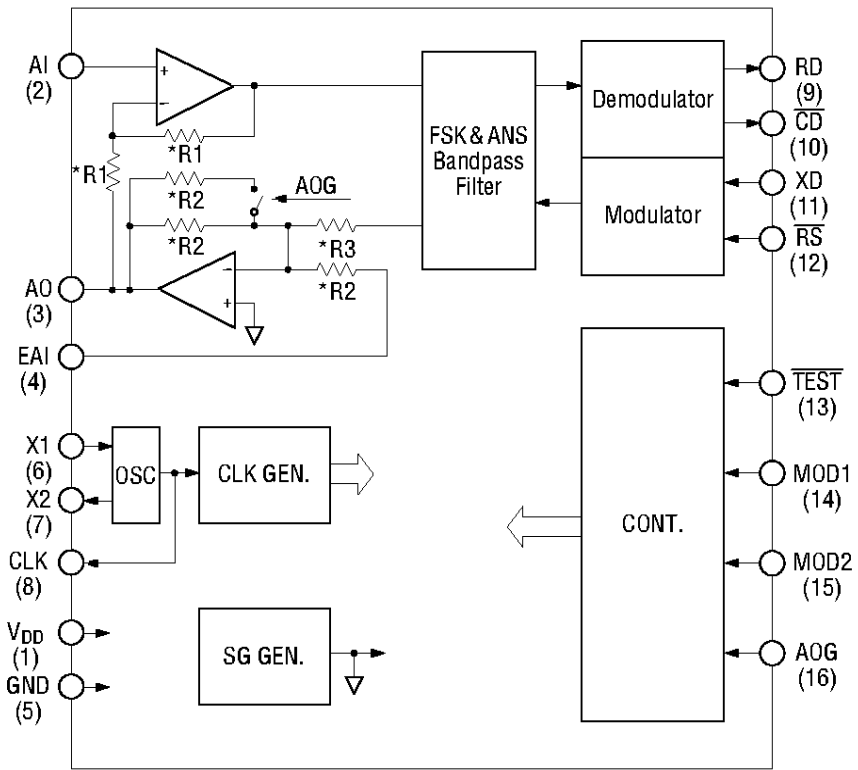

* R1 to R3 ≥ 50 kΩ

() : for MSM7512BRS

PIN CONFIGURATION (TOP VIEW)

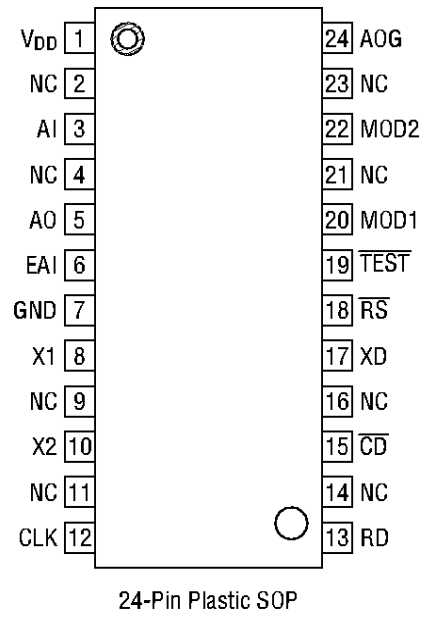
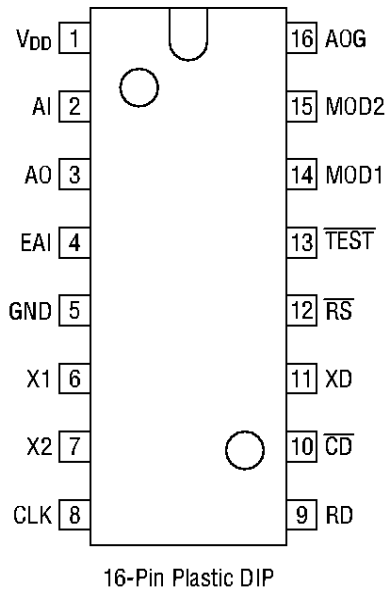

NC : No connect pin

PIN DESCRIPTION

No.		Name	I/O	Description
RS	GS-VK			
1	1	V _{DD}	—	+3 V to +5 V Power Supply
2	3	AI	I	Analog receive signal input.
3	5	AO	O	Analog transmit signal output.
4	6	EAI	I	External analog signal input. The signal applied to this pin is transmitted from AO via transmit output amplifier. When not using this pin, it should be left open.
5	7	GND	—	Ground, 0 V.
6	8	X1	I	3.579545 MHz crystal resonator should be connected to X1 and X2. When applying external clock 3.579545 MHz to the device, it should be applied to X2 (not X1) via an AC-coupling capacitor of 100 pF and X1 has to be opened.
7	10	X2	O	
8	12	CLK	O	3.579545 MHz clock signal output.
9	13	RD	O	Modem receive serial data output. Digital "1" and "0" correspond to "Mark" and "Space", respectively. When $\overline{\text{CD}}$ (Carrier Detect) is off, RD is held at "Mark" state.
10	15	$\overline{\text{CD}}$	O	FSK Receive signal and answer tone detect. Digital "0" and "1" represent "Detect" and "Non-detect", respectively.
11	17	XD	I*	Modem transmit serial data input. Digital "1" and "0" correspond to "Mark" and "Space", respectively.
12	18	$\overline{\text{RS}}$	I*	FSK signal and answer tone transmit enable. When digital "0" is applied to $\overline{\text{RS}}$, transmitting becomes enable.
13	19	$\overline{\text{TEST}}$	I*	Chip test input. $\overline{\text{TEST}}$ should be open or digital "1".
14	20	MOD1	I*	Operation mode select.
15	22	MOD2	I*	Refer to Table 1.
16	24	AOG	I*	Analog transmit signal amplitude select. Digital "1" → -10 dBm Typ. at AO Digital "0" → -4 dBm Typ. at AO

Note : I* : Internally pulled-up input pin.

ABSOLUTE MAXIMUM RATINGS

Parameter	Symbol	Condition	Rating	Unit
Power Supply Voltage	V_{DD}	$T_a = 25^\circ\text{C}$,	-0.3 to +7	V
Input Voltage	V_{IN}	With respect to GND	-0.3 to $V_{DD} + 0.3$	V
Storage Temperature	T_{STG}	—	-55 to +150	$^\circ\text{C}$

RECOMMENDED OPERATING CONDITIONS

Parameter	Symbol	Condition	Min.	Typ.	Max.	Unit	
Power Supply Voltage	V_{DD}	—	+2.7	—	+5.5	V	
Operating Temperature	T_{op}	—	-40	—	+85	$^\circ\text{C}$	
Input Clock Frequency	f_{CLK}	To 3.579545 MHz	-0.1	—	+0.1	%	
V_{DD} Bypass Capacitor	C_{VDD}	$V_{DD} - \text{GND}$	10	—	—	μF	
Crystal	Oscillation Frequency	—	—	3.579545	—	MHz	
	Frequency Deviation	—	+25 $^\circ\text{C}$ \pm 5 $^\circ\text{C}$	-100	—	+100	ppm
	Temperature Characteristics	—	-40 $^\circ\text{C}$ to +85 $^\circ\text{C}$	-50	—	+50	ppm
	Equivalent Series Resistance	—	—	—	—	50	Ω
	Load Capacitance	—	—	—	16	—	pF

ELECTRICAL CHARACTERISTICS

DC Characteristics

($V_{DD} = +2.7\text{ V to }+5.5\text{ V}$, $T_{op} = -40^\circ\text{C to }+85^\circ\text{C}$)

Parameter	Symbol	Condition	Min.	Typ.	Max.	Unit
Power Supply Current	I_{DD}	Operating Mode	—	5.0	10.0	mA
	I_{SS}	Power Down Mode	—	5.0	20.0	μA
Digital Input Voltage	V_{IL}	—	0	—	0.8	V
	V_{IH}	—	2.2	—	V_{DD}	V
Digital Input Leakage Current	I_{IL}	$V_I = 0\text{ V}^*$	-80	—	10	μA
	I_{IH}	$V_I = 5\text{ V}$	-10	—	10	μA
Digital Output Voltage	V_{OL}	$I_{OL} = 1.6\text{ mA}$	0	0.2	0.4	V
	V_{OH}	$I_{OH} = -0.4\text{ mA}$	2.4	—	V_{DD}	V

* Internally pulled-up pins

AC Characteristics

Modulator/analog output (AO) characteristics

(V_{DD} = +2.7 V to +5.5 V, Top = -40°C to +85°C)

Parameter	Symbol	Condition		Min.	Typ.	Max.	Unit
FSK Transmit Signal Frequency	f _{DM}	1200 bps Transmit Mode	XD = "1"	1296	1300	1304	Hz
	f _{DS}		XD = "0"	2096	2100	2104	Hz
Signal Frequency	f _{BM}	75 bps Transmit Mode	XD = "1"	386	390	394	Hz
	f _{BS}		XD = "0"	446	450	454	Hz
FSK Transmit Signal Answer Tone amplitude	V _{AO1}	V _O	AOG = "0"	-6	-4	-2	dBm
	V _{AO2}		AOG = "1"	-12	-10	-8	dBm
Analog External Input Signal Gain	V _{EA1}	V _{AO} - V _{EAI}	AOG = "0"	-2	0	2	dB
	V _{EA2}		AOG = "1"	-8	-6	-4	dB
FSK Transmit Signal Amplitude Ratio	V _{AOD}	V _{AO} (MARK) - V _{AO} (SPACE)		-2	0	2	dB
Out-of-band Energy	V _{SPS}	P : In-band Signal Energy	4 kHz to 8 kHz	—	—	P-20	dB
			8 kHz to 12 kHz	—	—	P-40	dB
			More than 12 kHz	—	—	P-60	dB
Output Offset Voltage	V _{OFF}	To V _{DD} /2		-150	—	+150	mV
Output Load Resistance	R _{AO}	—		600	—	—	Ω

* 0 dBm = 0.775 Vrms

Demodulator analog input (AI, EAI) characteristics

($V_{DD} = +2.7\text{ V to }+5.5\text{ V}$, $T_{op} = -40^{\circ}\text{C to }+85^{\circ}\text{C}$)

Parameter	Symbol	Condition	Min.	Typ.	Max.	Unit	
Receive Signal Amplitude	V_{AI}	FSK Signal, at AI	—	—	-6	dBm	
Receive Signal Detect Amplitude (\overline{CD})	V_{ON}	FSK Signal, (1:1) at AI	OFF \rightarrow ON	—	—	-42	dBm
	V_{OFF}		OFF \rightarrow OFF	-48	—	—	dBm
Hysteresis (\overline{CD})	V_{HYS}	$V_{ON} \rightarrow V_{OFF}$	—	2	—	dB	
\overline{CD} Delay Time	t_{CDD}	See Fig. 1	5	15	20	ms	
\overline{CD} Hold Time	t_{CDH}		20	40	60	ms	
Receive Data (\overline{RD}) Bias Distortion	D_{BS}	1200 bps, 1:1 Pattern	-10	—	10	%	
Input Resistance	R_{AI}	AI	—	10	—	M Ω	
	R_{EAI}	EAI	20	—	—	k Ω	

* 0 dBm = 0.775 Vrms

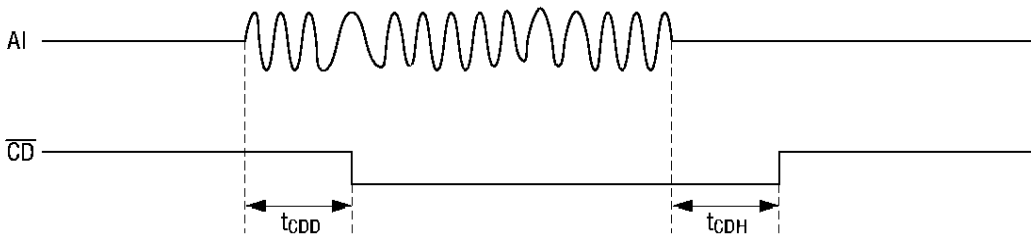

Figure 1 Carrier Detect (\overline{CD}) Timing

OPERATION MODE

Table 1 Operation Mode

MOD2	MOD1	Mode
0	0	FSK Transmit Mode (Fig.2)
0	1	FSK Receive & 75 bps Transmit Mode (Fig.3)
1	0	Analog Loop Back Test Mode (Fig. 4)
1	1	Power Down Mode

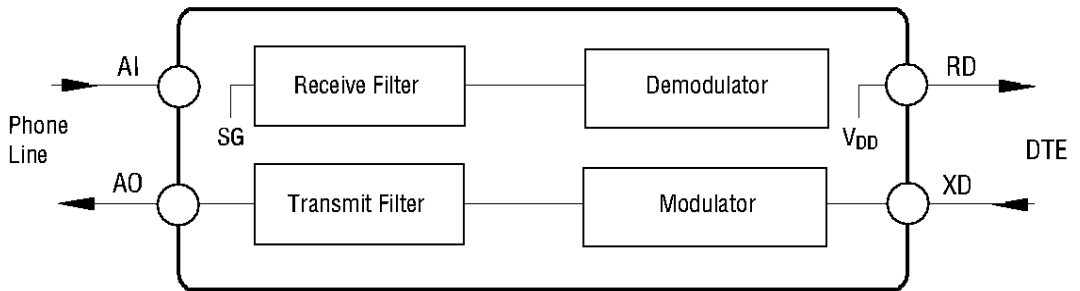

Figure 2 FSK Transmit Mode

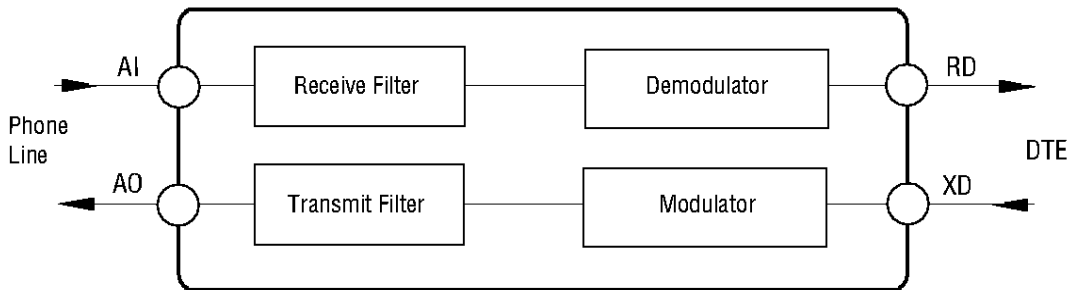

Figure 3 FSK Receive Mode

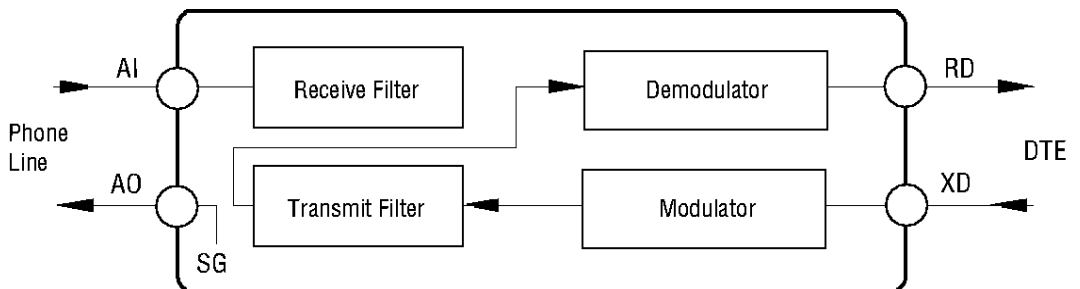
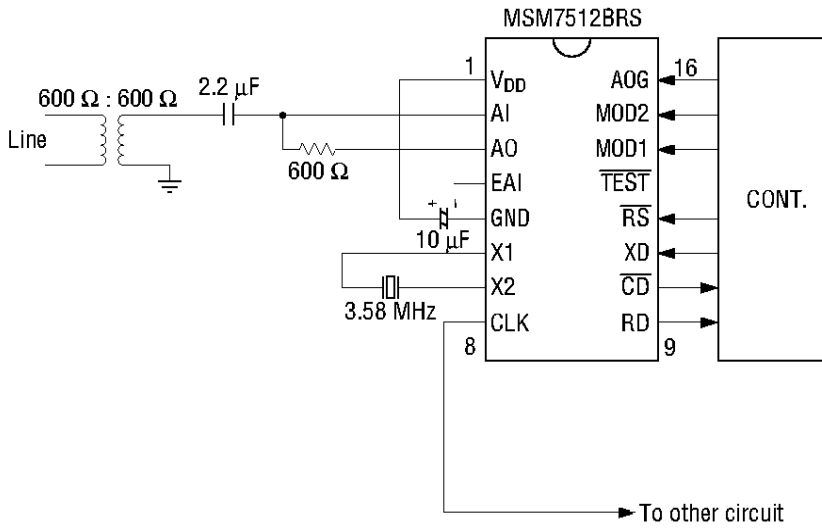

Figure 4 Analog Loop Back Test Mode

APPLICATION CIRCUIT

①



②

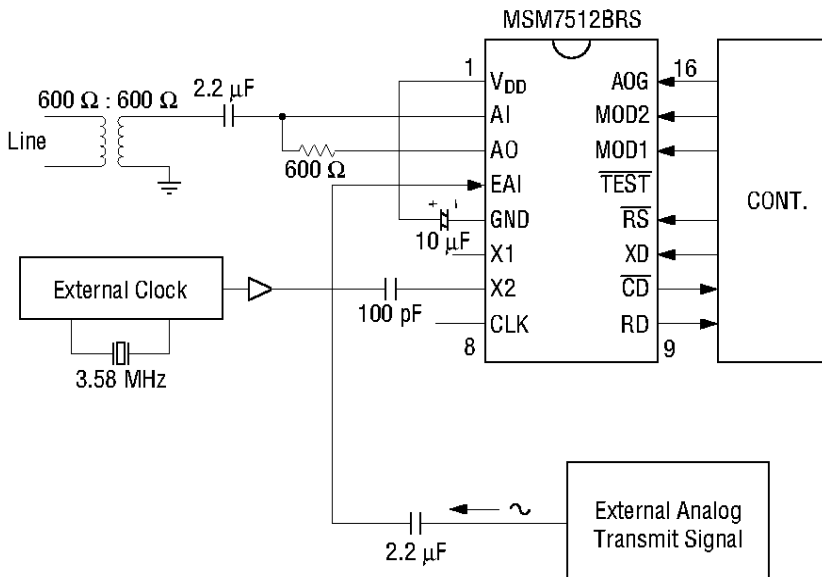

An Example of the External Adjustment for a transmitting Level and detecting Level

If you desire to change the transmitting level or detecting level, adjust the external circuit by referring to the following circuit.

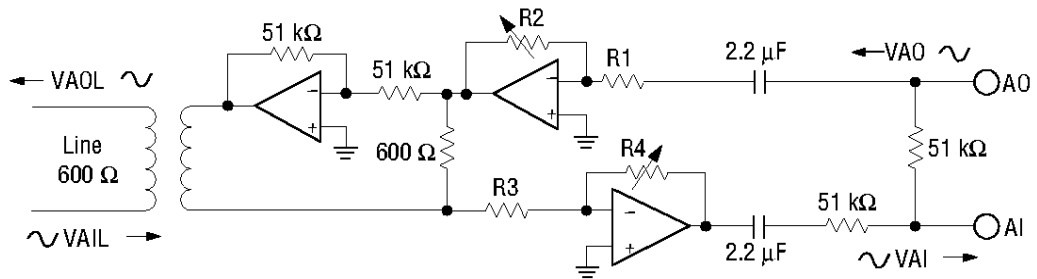

Line transmitting level : $V_{AOL} = V_{AO} \times (R2/R1)$
 IC input level : $V_{AI} = V_{AIL} \times (R4/R3)$

PACKAGE DIMENSIONS

(Unit : mm)

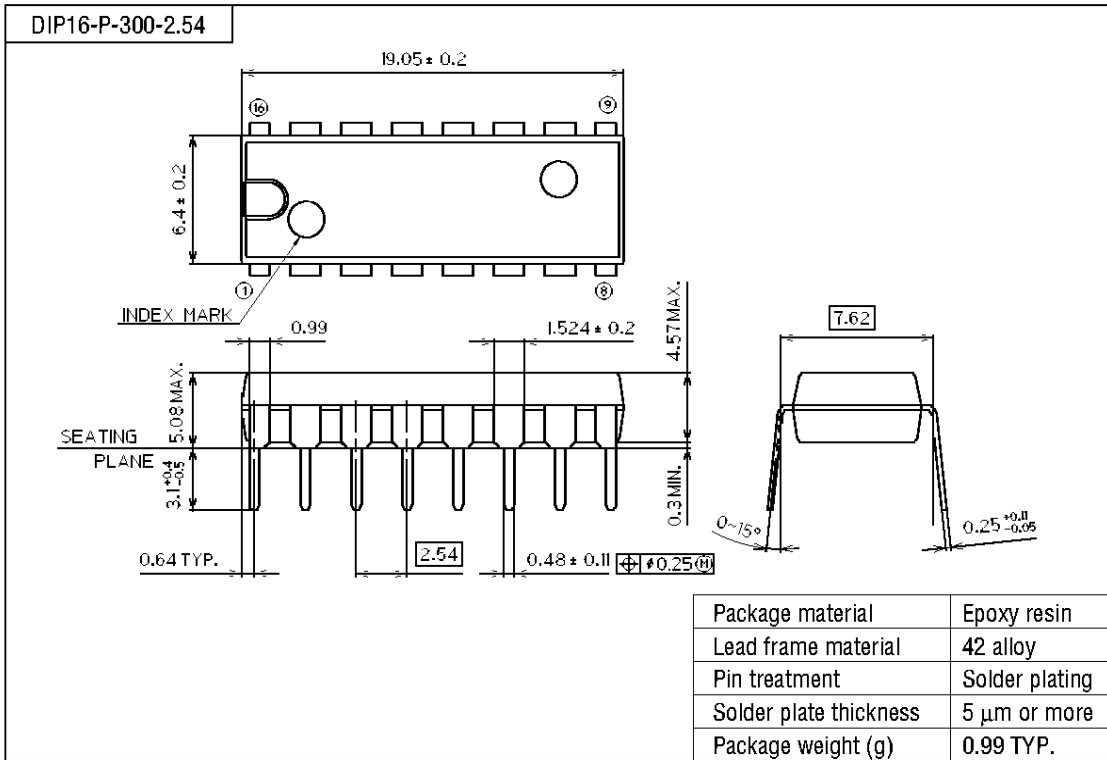

(Unit : mm)

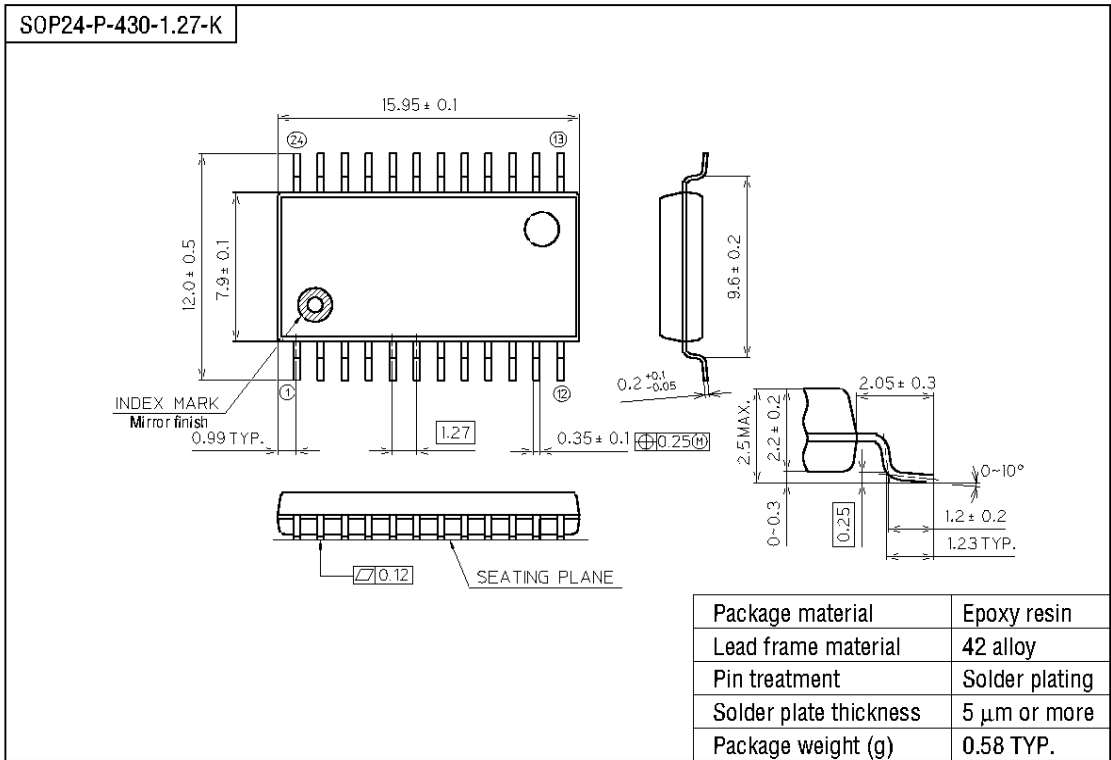

Notes for Mounting the Surface Mount Type Package

The SOP, QFP, TSOP, SOJ, QFJ (PLCC), SHP and BGA are surface mount type packages, which are very susceptible to heat in reflow mounting and humidity absorbed in storage. Therefore, before you perform reflow mounting, contact Oki's responsible sales person for the product name, package name, pin number, package code and desired mounting conditions (reflow method, temperature and times).