



HI-6210

Fully Integrated
MIL-STD-1553 BC/RT/MT

HI-6210, HI-6211, HI-6212 Families

July 2022

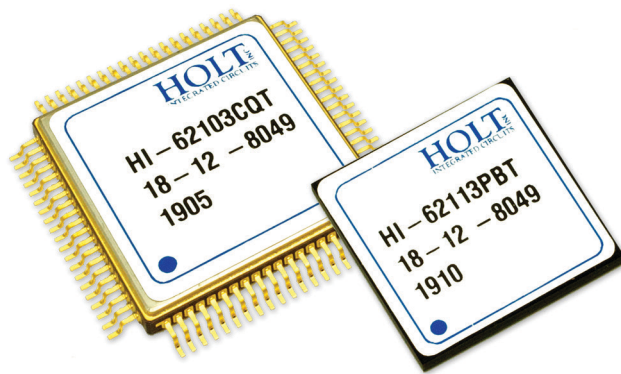

1. Overview

The HI-6210/11/12 family is a fully integrated and dual redundant MIL-STD-1553 BC/RT/MT interface solution which includes 1553 protocol, SRAM and dual transceivers in single plastic BGA and ceramic package configurations. The devices are direct pin compatible drop-in replacements for the Data Device Corporation (DDC®) Micro-ACE® TE and Mini-ACE® Mark3 Families of MIL-STD-1553 Terminals.

1.1. Bus Controller

The BC is a programmable message-sequencing engine programmed using a set of 20 instruction op codes. It greatly reduces the host's processing workload by autonomously supporting multi-frame message scheduling, message retry schemes, storage of message data in on-chip RAM, asynchronous message insertion and status/error reporting. The Enhanced BC mode also includes a General Purpose Queue and user-defined interrupts to further enhance host communication.

1.2. Remote Terminal

The RT has been fully validated by a recognized independent third party. RT memory management options include single, double, and 2 circular buffer modes for individual subaddresses. The RT performs comprehensive error checking including word and format validation and checks for various transfer errors. The RT supports flexible interrupt conditions, command illegalization and a programmable busy bit by subaddress. In addition, the HI-6210PB, HI-6211PB and HI-6212PB devices have an "auto-boot" feature necessary for MIL-STD-1760 compliance, whereby the terminal can initialize as an online RT with the busy bit set following power turn-on.

1.2.1. RT-only Mode with DMA Interface

The HI-62113PBx and HI-62115PBx devices may be configured as RT-only devices with a Direct Memory Access (DMA) interface and 4K SRAM. The mode provides a MIL-STD-1553 Remote Terminal interface for a system that doesn't include a microprocessor, such as A/D and D/A converters, actuators, and other discrete I/O signals. This mode is activated by simultaneously strapping three balls to ground.

1.3. Monitor Terminal

The family supports three monitor modes including a word monitor mode, a selective message monitor mode and a combined RT/Monitor Mode. For new applications it is recommended to implement the selective message monitor mode. Selective Message Monitor allows monitoring of 1553 messages and provides the ability to filter based on RT address, T/ \bar{R} bit and subaddress with no host processor intervention.

1.4. Host Processor Interface

Each device provides an 8/16-bit parallel host bus interface supporting a variety of processor configurations including shared RAM and DMA configurations. The host interface supports both non-multiplexed and multiplexed address/data buses, non-zero wait mode for interfacing to processor address/data buses, and zero wait mode for interfacing to microcontroller I/O ports.

Note: DDC®, Mini-ACE®, Enhanced Mini-ACE®, Micro-ACE®, Mini-ACE® Mark3 and Total-ACE® are registered trademarks of Data Device Corporation, Bohemia, NY, USA. There is no affiliation between Data Device Corporation and Holt Integrated Circuits Inc.

Overview

1.5. Built in Test

The family provides an autonomous built-in self-test capability. The testing includes both RAM and protocol logic tests which may be initiated by the host processor.

1.6. Features

- Dual Redundant MIL-STD-1553A/B/1760 Channel
- BC, RT, MT, or RT/MT Modes
- Configurable as an RT-only device with DMA interface and 4K SRAM (HI-62113PBx and HI-62115PBx devices)
- 64Kx17 or 4Kx16 SRAM
- External RT Address Inputs
- MIL-STD-1760 RT “Auto Boot” (HI-6210PB, HI-6211PB and HI-6212PB devices)
- +3.3V Single Supply on select devices
- Built-in Self-Test
- Generic 8/16-bit Processor Interface
- HI-62113PBx and HI-62115PBx may be configured as an RT-only device with DMA interface and 4K SRAM
 - Use as an interface to a system with no microprocessor
- -40°C to +85°C or -55°C to +125°C
 - No Limitations on transmit duty cycle
- 80-Pin Hermetic Gull Wing Package (HI-6210CQ and HI-6212CQ devices)
 - 22.4mm x 22.4mm x 3.6mm
- PBGA-324 (HI-6210PB, HI-6211PB and HI-6212PB devices)
 - 20.7mm x 20.7mm x 3.1mm

1.7. Application Benefits

- Simplified Board Design and Layout
- Third Party RT Validated
- Single Die for Improved Reliability
- Cost Effective Direct Drop-in Replacement for DDC[®] Mini-ACE[®] Mark3 and Micro-ACE[®] TE families
- Fully Software Compatible to DDC[®] ACE, Mini-ACE[®], Enhanced Mini-ACE[®], Micro-ACE[®], Mini-ACE[®] Mark3 and Total-ACE[®].

1.8. Cross Reference Guide

Holt P/N	DDC P/N
HI-62115PBxF	BU-64840R3-xxx
HI-62115PBx	BU-64840B3-xxx
HI-62113PBxF	BU-64843RC-xxx
HI-62113PBx	BU-64843BC-xxx
HI-62106PBx	BU-64860B4-xxx
HI-62105PBxF	BU-64860R3-xxx
HI-62105PBx	BU-64860B3-xxx
HI-62103PBxF	BU-64863RC-xxx
HI-62123PBx	BU-64743BC-xxx
HI-62123CQx	BU-64743GC-xxx
HI-62124CQx	BU-64743GD-xxx
HI-62125CQx	BU-64745G3-xxx
HI-62114CQx	BU-64843GD-xxx
HI-62105CQx	BU-64863G3-xxx
HI-62104CQx	BU-64863GD-xxx
HI-62103CQx	BU-64863GC-xxx

Overview

1.9. Block Diagram

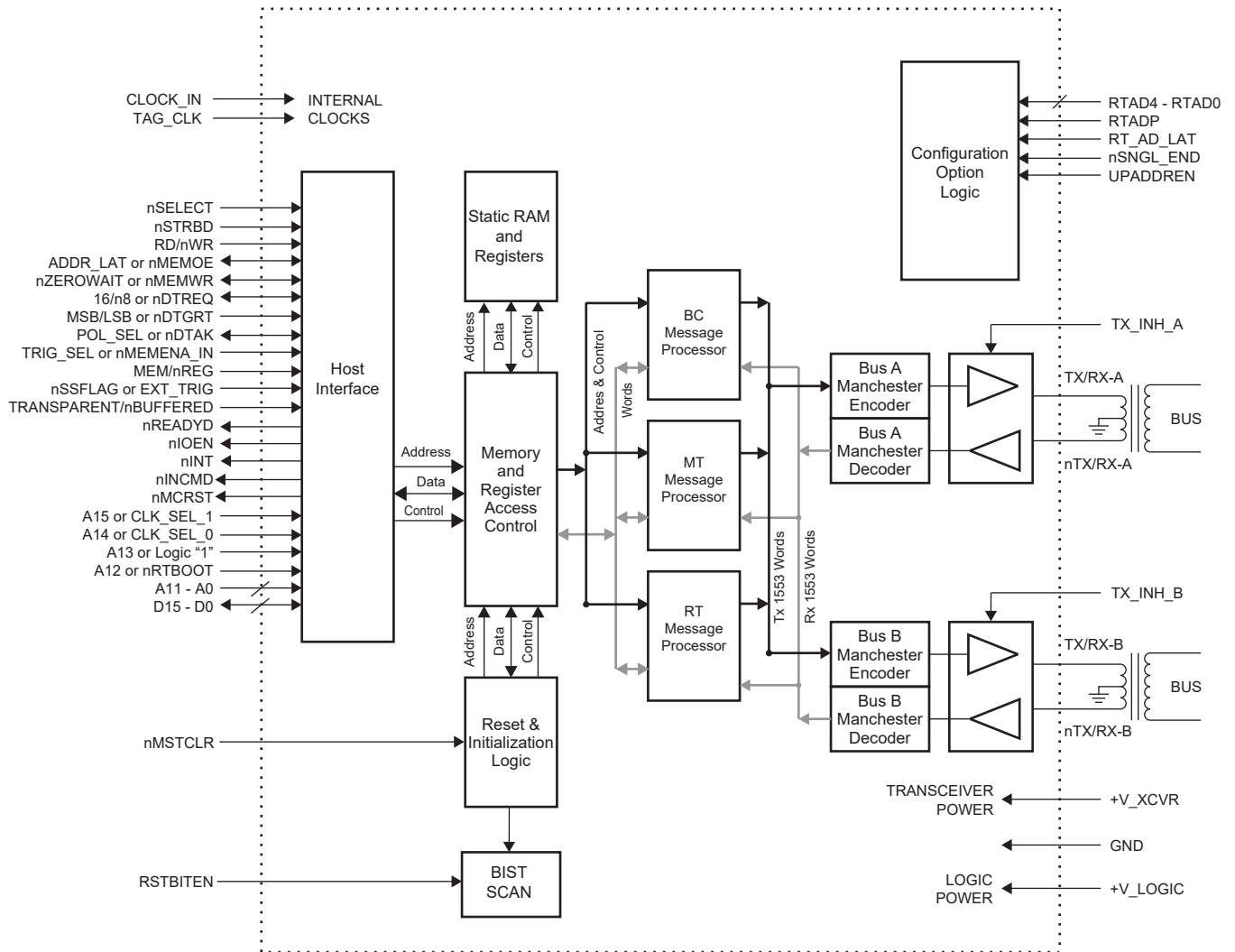

2. Registers and Command/Status Words

Table 1 summarizes the device registers and corresponding addresses.

Table 1. Register Summary

Hex Address	Access	Register Name	Hard Reset Default
0x0000	RD/WR	Interrupt Enable Register 1	0x0000
0x0001	RD/WR	Configuration Register 1	0x0000
0x0002	RD/WR	Configuration Register 2	0x0000
0x0003	WR	Start/Reset Register	0x0000
0x0003	RD	Non-Enhanced BC or RT Command Stack Pointer / Enhanced BC Instruction List Pointer Register	0x0000
0x0004	RD/WR	BC Control Word / RT Subaddress Control Word Register	0x0000
0x0005	RD/WR	Time Tag Register	0x0000
0x0006	RD	Interrupt Status Register 1	0x0000
0x0007	RD/WR	Configuration Register 3	0x0000
0x0008	RD/WR	Configuration Register 4	0x0000
0x0009	RD/WR	Configuration Register 5	Note 1
0x000A	RD/WR	RT/Monitor Data Stack Address Register	0x0000
0x000B	RD	BC Frame Time Remaining Register	0x0000
0x000C	RD	BC Time Remaining to Next Message Register	0x0000
0x000D	RD/WR	Non-Enhanced BC Frame Time / Enhanced BC Initial Instruction Pointer / RT Last Command/MT Trigger Word Register	0x0000
0x000E	RD	RT Status Word Register	0x0000
0x000F	RD	RT BIT Word Register	0x0000
0x0010	-	Test Mode Register 0	0x0000
0x0011	-	Test Mode Register 1	0x0000
0x0012	-	Test Mode Register 2	0x0000
0x0013	-	Test Mode Register 3	0x0000
0x0014	-	Test Mode Register 4	0x0000
0x0015	-	Test Mode Register 5	0x0000
0x0016	-	Test Mode Register 6	0x0000

Registers and Command/Status Words

Hex Address	Access	Register Name	Hard Reset Default
0x0017	-	Test Mode Register 7	0x0000
0x0018	RD/WR	Configuration Register 6	0x0000
0x0019	RD/WR	Configuration Register 7	0x0000
0x001A	-	Reserved	0x0000
0x001B	RD	BC Condition Code Register	0x0000
0x001B	WR	BC General Purpose Flag Register	0x0000
0x001C	RD	BIT Test Status Register	Note 2
0x001D	RD/WR	Interrupt Enable Register 2	0x0000
0x001E	RD	Interrupt Status Register 2	Note 2
0x001F	RD/WR	BC General Purpose Queue Pointer / RT-MT Interrupt Status Queue Pointer Register	0x0000

NOTES:

1. Bits SNGLEND, TXINHA, TXINHB, RTAD[4:0] and RTADP will reflect the logic values of their respective input pins.
2. Following Built-in Self Test, registers 0x001C (BIT Test Status Register) and 0x001E (Interrupt Status Register 2) will be non-zero. The value of register 0x001C will depend on the result of the Built-in Self Test. In register 0x001E, bit 2, BIST, will be set to logic "1" following Built-in Self Test.

2.1. Interrupt Enable Register #1, Read/Write 0x0000

Setting a respective bit below to logic “1” will cause an interrupt to be generated when the corresponding event occurs. The equivalent bit in Interrupt Status Register #1 will also be set to logic “1” regardless of whether the enable bit is set or not. Setting a respective bit below to logic “0” will disable (mask) the interrupt.

Bit No.	Mnemonic	R/W	Reset	Bit Description
15 (MSB)		–	0	Reserved
14	RAMPE	R/W	0	Set RAMPE to logic “1” to generate an interrupt when a RAM parity error occurs. Note: RAM PARITY ERROR must be set to logic “0” for 4K RAM device options, since there is no 17-bit RAM for these devices.
13	TXTO	R/W	0	Set TXTO to logic “1” to generate an interrupt when a transmitter timeout occurs.
12	STKRO	R/W	0	Set STKRO to logic “1” to generate an interrupt when a command stack rollover occurs. When in BC Mode, this applies to the BC Command Stack. When in RT Mode, this applies to the RT Command Stack.
11	MTRO	R/W	0	Set MTRO to logic “1” to generate an interrupt when an MT command stack rollover occurs.
10	MTDRO	R/W	0	Set MTDRO to logic “1” to generate an interrupt when an MT data stack rollover occurs.
9	HSKF	R/W	0	Set HSKF to logic “1” to generate an interrupt when a handshake failure occurs between the device and external RAM in Transparent Mode.
8	BCRTY	R/W	0	Set BCRTY to logic “1” to generate an interrupt when the BC tries to re-send a message, regardless of whether the retry was successful or not.
7	RTAPF	R/W	0	Set RTAPF to logic “1” to generate an interrupt when the The Remote Terminal address and parity bits do not exhibit odd parity.
6	TTRO	R/W	0	Set TTRO to logic “1” to generate an interrupt when the time tag counter rolls over.
5	RTCIRO	R/W	0	Set RTCIRO to logic “1” to generate an interrupt when the RT circular buffer rolls over
4	CWEOM	R/W	0	Set CWEOM to logic “1” to generate an interrupt at the end of the current message provided the EOM interrupt is enabled in the respective BC or RT subaddress control word.
3	BCEOF	R/W	0	Set BCEOF to logic “1” to generate an interrupt at the end of the current BC frame
2	ERR	R/W	0	Set ERR to logic “1” to generate an interrupt when a 1553 Message Error, loopback failure or response timeout is detected

Registers and Command/Status Words

Bit No.	Mnemonic	R/W	Reset	Bit Description	
1	BRMINT	R/W	0	The function of this bit depends on whether the device is operating in BC, RT or MT mode as follows: Set BRMINT to logic "1" to generate an interrupt when the conditions below are met:	
				BC Mode	A received RT Status Word contains the wrong RT address or an unexpected status bit value.
				Enhanced RT Mode	A valid Mode Command is received.
				Word Monitor Mode	A valid received command word matches the value programmed in the Monitor Trigger Register.
0 (LSB)	EOM	R/W	0	Set EOM to logic "1" to generate an interrupt at the end of every message.	

2.2. Configuration Register #1, Read/Write 0x0001

Configuration Register #1 is used to select the device's mode of operation and for software control of operational features such as RT Status Word bits, Time-Tagging, etc. Specific bit functionality depends on the selected mode of operation as outlined in the Tables below.

Table 2. Configuration Register #1, Non-Enhanced BC Mode (Legacy).

Bit No.	Mnemonic	R/W	Reset	Bit Description
15 (MSB)	MODE1	R/W	1	Set to logic "0" for BC mode of operation.
14	MODE2	R/W	0	Initializes logic "0" in BC mode.
13	MEMAB	R/W	0	This bit indicates which fixed memory location is used. If MEMAB is logic "0", Location A is used If MEMAB is logic "1", Location B is used.
12	ABRTME	R/W	0	Set ABORTME to logic "1" to abort message processing at the end of the current message when the BC encounters a message error. BC Message processing will continue if an optional message retry is successful.
11 – 0	-	R/W	0	Used only in Enhanced BC Mode (see below)

Registers and Command/Status Words

Table 3. Configuration Register #1, Enhanced BC Mode.

To enable Enhanced BC Mode, bit 15 of Configuration Register #1 should be set to logic “0” **AND** bit 15 of Configuration Register #3 should be set to logic “1”.

Bit No.	Mnemonic	R/W	Reset	Bit Description
15 (MSB)	MODE1	R/W	1	Set to logic “0” for BC mode of operation.
14	MODE2	R/W	0	Initializes logic “0” in BC mode.
13	MEMAB	R/W	0	Current Memory Pointer. Logic “0” for Location A, logic “1” for Location B.
12	ABRTME	R/W	0	Abort at End of Message if Error. Set to logic “1” to abort message processing at the end of the current message when the BC encounters an error. BC Message processing will continue if the message retry feature is enabled and retry is successful.
11	ABRTFE	R/W	0	Abort at End of Frame if Error. Set to logic “1” to abort message processing at the end of the current frame when the BC encounters an error. BC Message processing will continue if the message retry feature is enabled and retry is successful.
10	ABRTMES	R/W	0	Abort at End of Message if Status Bits Set. Set to logic “1” to abort message processing at the end of the current message when non-masked Status Word bits are set unexpectedly. BC Message processing will continue if the message retry feature is enabled and retry is successful.
9	ABRTFES	R/W	0	Abort at End of Frame if Status Bits Set. Set to logic “1” to abort message processing at the end of the current frame (even if Auto Frame Repeat is enabled) when non-masked Status Word bits are set unexpectedly. BC Message processing will continue if the message retry feature is enabled and retry is successful.
8	AFR	R/W	0	Auto Frame Repeat. Logic “0”: The host manually starts each BC frame. Logic “1”: BC frame will repeat indefinitely provided none of the conditions outlined in bits 12:9 occur or the part is not reset. A fixed frame time may be set by setting bit 6, Internal Trigger below.
7	ETRIG	R/W	0	External Trigger. Set to logic “1” to start BC message processing via rising edge of EXT_TRIG signal.

Registers and Command/Status Words

Bit No.	Mnemonic	R/W	Reset	Bit Description
6	ITRIG	R/W	0	<p>Internal Trigger.</p> <p>This bit is used in conjunction with bit 8, Auto Frame Repeat, to automatically repeat the BC frame with a fixed frame time. The time is set in increments of 100μs (up to 6.55 sec.) according to the value specified by the BC Frame Time Register.</p> <p>Logic "1": Enable.</p> <p>Logic "0": Disable. Stop after a single frame.</p>
5	GAPTMR	R/W	0	<p>Message Gap Timer.</p> <p>Logic "0": Default message gap (~10μs).</p> <p>Logic "1": The message gap is defined in steps of 1μs in the third word of the BC Message Block Descriptor (the defined value may be 10μs – 65.535 ms)</p>
4	RTY	R/W	0	<p>Message Retry.</p> <p>Logic "1": Enable BC message retries by setting bit 8 in the respective BC control word.</p> <p>Logic "0": Disable message retries.</p>
3	RTY2X	R/W	0	<p>If RTY2X is set to logic "1" and retries are enabled by setting bit 4 above, then the BC will retry again if the first attempt was unsuccessful.</p> <p>If RTY2X is set to logic "0", then retry only once.</p>
2	BCEN	R	0	<p>BC Enabled.</p> <p>Logic "1" indicates the BC state machine is enabled, i.e. is active and processing messages.</p> <p>Logic "0" indicates the BC is in Idle mode.</p>
1	BCFIP	R	0	<p>This bit will read logic "1" for the start of the first message to the end of the last message in a BC frame.</p>
0 (LSB)	BCMIP	R	0	<p>This bit will read logic "1" for the duration of all BC messages.</p>

Registers and Command/Status Words

Table 4. Configuration Register #1, RT Mode (without Alternate Status Word).

Configuration Register #3, bit 5 = logic “0”. For Enhanced RT operation, bit 15 of Configuration Register #3 should be set to logic “1”.

Bit No.	Mnemonic	R/W	Reset	Bit Description
15 (MSB)	MODE1	R/W	1	Set to logic “1” for RT mode of operation.
14	MODE2	R/W	0	If bit 15 is logic “1” for RT operation, this bit should be logic “0”. In this case, enable MT mode (i.e. RT/MT) by setting bit 12 of this register.
13	MEMAB	R/W	0	Current Memory Pointer. Logic “0” for Location A, logic “1” for Location B.
12	MTEN	R/W	0	Message Monitor Enable Logic “1”: Enable Message Monitor. Logic “0”: Disable Message Monitor.
11	DBAC	R/W	0	Dynamic Bus Control Acceptance, active low. Logic “0”: The RT will respond to a Dynamic Bus Control Mode Code Command by setting the Dynamic Bus Control Acceptance bit in the RT Status Word. Logic “1”: The Dynamic Bus Control Acceptance bit in the RT Status Word will always be zero.
10	BUSY	R/W	0	Busy Bit, active low. Logic “0” will result in “busy” status set. The RT will not respond to commands and will transmit the RT Status Word with the busy bit set. Logic “1” results in the busy bit not set in the RT Status Word and the RT will respond to commands in the normal way.
9	SVCREQ	R/W	0	Service Request Bit, active low. Logic “0” will result in the Service Request bit set in the RT Status Word. Logic “1” will result in the Service Request bit not set in the RT Status Word.
8	SSYS	R/W	0	Subsystem Flag Bit, active low. Logic “0” will result in the Subsystem Flag bit set in the RT Status Word. Logic “1” will result in the Subsystem Flag bit not set in the RT Status Word.

Registers and Command/Status Words

Bit No.	Mnemonic	R/W	Reset	Bit Description
7	TF	R/W	0	Terminal Flag Bit, active low. Enhanced Mode only (Configuration Register #3, bit 15 = logic "1"). Logic "0" will result in the Terminal Flag bit set in the RT Status Word. Logic "1" will result in the Terminal Flag bit not set in the RT Status Word.
6 - 1		-	-	Not used.
0 (LSB)	RTMIP	R	0	RT Message in Progress. Enhanced Mode only (Configuration Register #3, bit 15 = logic "1"). Logic "1" indicates the RT is processing a message. Set just before SOM and reset just after EOM.

Table 5. Configuration Register #1, RT Mode (with Alternate Status Word).

Configuration Register #3, bit 5 = logic "1". Bits 11 – 1 of the RT status word are programmable directly by the host. For use of the RT Alternate Status word, Enhanced RT operation must be activated (bit 15 of Configuration Register #3 should be set to logic "1").

Bit No.	Mnemonic	R/W	Reset	Bit Description
15 (MSB)	MODE1	R/W	1	Set to logic "1" for RT mode of operation.
14	MODE2	R/W	0	Set to logic "0" for RT mode of operation.
13	MEMAB	R/W	0	Current Memory Pointer. Logic "0" for Location A, logic "1" for Location B.
12	MTEN	R/W	0	Message Monitor Enable Logic "1": Enable Message Monitor. Logic "0": Disable Message Monitor.
11	MERR	R/W	0	If this bit is logic "1", the Message Error bit (bit 9) of the RT Status Word will be set.
10	INS	R/W	0	If this bit is logic "1", the Instrumentation bit (bit 10) of the RT Status Word will be set.
9	SVCREQ	R/W	0	If this bit is logic "1", the Service Request bit (bit 11) of the RT Status Word will be set.
8	RSRV1	R/W	0	If this bit is logic "1", bit 12 of the RT Status Word will be set.
7	RSRV2	R/W	0	If this bit is logic "1", bit 13 of the RT Status Word will be set.
6	RSRV3	R/W	0	If this bit is logic "1", bit 14 of the RT Status Word will be set.

Registers and Command/Status Words

Bit No.	Mnemonic	R/W	Reset	Bit Description
5	BCST	R/W	0	If this bit is logic "1", Broadcast Command Received bit (bit 15) of the RT Status Word will be set.
4	BUSY	R/W	0	If this bit is written logic "1", the Busy bit (bit 16) of the RT Status Word will be set.
3	SSYS	R/W	0	If this bit is written logic "1", the Subsystem Flag bit (bit 17) of the RT Status Word will be set.
2	DBAC	R/W	0	If this bit is written logic "1", bit 18 of the RT Status Word will be set.
1	TF	R/W	0	If this bit is written logic "1", the Terminal Flag bit (bit 19) of the RT Status Word will be set.
0 (LSB)	RTMIP	R	0	RT Message in Progress. Logic "1" indicates the RT is processing a message. Set just before SOM and reset just after EOM.

Table 6. Configuration Register #1, Enhanced Monitor Mode.

Enhanced mode is activated by setting bit 15 of Configuration Register #3 to logic "1". Bits 15 – 13 apply to both Enhanced and non-Enhanced Modes. Bits 12 – 0 only apply in Enhanced Mode.

Bit No.	Mnemonic	R/W	Reset	Bit Description
15 (MSB)	MODE1	R/W	1	Set to logic "0" for MT mode of operation.
14	MODE2	R/W	0	Set to logic "1" for MT mode of operation.
13	MEMAB	R/W	0	Current Memory Pointer. Logic "0" for Location A, logic "1" for Location B.
12	MTEN	R/W	0	Message Monitor Enable Logic "1": Enable Message Monitor. Logic "0": Disable Message Monitor.
11	TRIGEN	R/W	0	Word Monitor Trigger Enable. Enable with logic "1". This bit must be set in Word Monitor Mode to enable a monitor start via EXT_TRIG (bit 7 below set to logic "1") or via successful comparison between a received valid word and the word stored in the MT Trigger Register (0x00D).
10	TRSTRT	R/W	0	Start Word Monitor on Trigger. Enable with logic "1". The Word Monitor will start monitoring following successful comparison between a received valid word and the word stored in the MT Trigger Register (0x00D).

Registers and Command/Status Words

Bit No.	Mnemonic	R/W	Reset	Bit Description
9	TRSTOP	R/W	0	Stop Word Monitor on Trigger. Enable with logic "1". The Word Monitor will stop monitoring following successful comparison between a received valid word and the word stored in the MT Trigger Resister (0x00D).
8	-	-	-	Not used.
7	EXTTRIG	R/W	0	External Trigger. Set to logic "1" to start MT via rising edge of EXT_TRIG signal. Monitor trigger must also be enabled by setting bit 11 of this register.
6 - 3	-	-	-	Not used.
2	MEN	R	0	Monitor Enabled. A logic "1" indicates the Monitor is enabled.
1	MTR	R	0	Monitor Triggered. A logic "1" indicates the Monitor was triggered either by successful comparison with the word in the MT Trigger Resister (0x00D) or via rising edge of the EXT_TRIG signal..
0 (LSB)	MACT	R	0	Monitor Active. A logic "1" indicates the Word Monitor was started.

2.3. Configuration Register #2, Read/Write 0x0002

Bit No.	Mnemonic	R/W	Reset	Bit Description			
15 (MSB)	EINTEN	R/W	0	Set EINTEN to logic "1" to enable Enhanced Interrupts.			
14	RAMP	R/W	0	Set RAMP to logic "1" to enable parity checking in the internal RAM.			
13	BUSYLU	R/W	0	Set BUSYLU to logic "1" to enable the Busy Lookup Table.			
12	DBUF	R/W	0	Set DBUF to logic "1" to enable Double Buffering for Rx messages (see bit 1 below).			
11	OVINV	R/W	0	Setting OVINV to logic "1" will cause invalid circular buffer data to be overwritten.			
10	256RO	R/W	0	If 256RO is logic "0", RAM buffers will rollover after 256 words.			
9 – 7	TTRES	R/W	0	Time Tag Resolution bits. Bits 9 – 7 set the time tag resolution as follows:			
				Bit 9	Bit 8	Bit 7	Time Tag Resolution
				0	0	0	64 μ s
				0	0	1	32 μ s
				0	1	0	16 μ s
				0	1	1	8 μ s
				1	0	0	4 μ s
				1	0	1	2 μ s
				1	1	0	The Time Tag is incremented by writing logic "1" to bit 4 of the Start/Reset Register.
1	1	1	The Time Tag is incremented by means of an external clock connected to TAG_CLK.				
6	TTSYNC	R/W	0	In RT Mode, setting this bit to logic "1" will clear the Time Tag counter when a Synchronize Without Data mode command is received.			
5	SYNCDAT	R/W	0	In RT Mode, setting this bit to logic "1" will cause the data word in a received Synchronize With Data mode command to loaded into the Time Tag Register. In BC Mode, setting this bit to logic "1" will allow the value of the Time Tag Register to be transmitted as the data word in a Synchronize With Data mode command.			
4	CLRSTAT	R/W	0	Logic "1": Clear Interrupt Status Registers #1 or #2 when read respectively. Logic "0": Clear both Interrupt Status Registers #1 and #2 by writing logic "1" to bit 2, Start/Reset Register 0x003.			

Registers and Command/Status Words

Bit No.	Mnemonic	R/W	Reset	Bit Description
3	LEVEL	R/W	0	<p>This bit sets whether the interrupt output signal INT is a continuous level or a pulse.</p> <p>Logic "1": The $\overline{\text{INT}}$ output signal will be a level that will remain low until Interrupt Status Registers #1 and #2 are cleared.</p> <p>Logic "0": The $\overline{\text{INT}}$ output signal will be a 500ns pulse.</p>
2	SRREQ	R/W	0	<p>Logic "0": The Service Request bit in the RT Status Word may only be controlled by the host.</p> <p>Logic "1": The Service Request bit in the RT Status Word may be controlled by the host, but is cleared when the RT responds to a Transmit Vector Word mode code command</p>
1	ENRTBUF	R/W	0	<p>This bit is used to set the Enhanced RT buffering mode.</p> <p>ENRTBUF = logic "0": If bit 12 of this register is logic "1", double buffer mode will be set globally for all Rx commands. If bit 12 is logic "0", single buffer mode will be set.</p> <p>ENRTBUF = logic "1": Each Rx subaddress can have a different buffering mode, set by the individual subaddress control word.</p>
0 (LSB)	NOTICE2	R/W	0	<p>Notice 2 Broadcast Data Storage.</p> <p>If this bit is logic "1", the terminal stores data associated with broadcast commands separately from data associated with non-broadcast commands to meet the requirements of MIL-STD-1553B Notice 2.</p> <p>If this bit is logic "0", broadcast command data is stored in the same buffer with data from nonbroadcast commands.</p>

2.4. Command Stack Pointer Register/ Enhanced BC Instruction List Register, Read Only 0x0003

When read, this register contains the current value of the Stack Pointer for RT, MT and non-enhanced BC modes. In Enhanced BC Mode, this register will contain a pointer to the BC Instruction List.

Bit No.	R/W	Reset	Bit Description
15 (MSB) – 0 (LSB)	R	0	Command Stack Pointer, bits[15 – 0] respectively.

2.5. Start/Reset Register, Write Only 0x0003

When writing to this register, all reserved bits must be written logic “0”.

Bit No.	Mnemonic	R/W	Reset	Bit Description
15 (MSB) – 12		W	0	Reserved.
11	RTON	W	0	If the RT goes offline following receipt of an Initiate Self-Test mode command (RTOFF bit 4 of Configuration Register #7 set), then the RT will automatically restart following completion of the self-test. However, if the host does not run the self-test by setting bit 7 of this register, then this bit should be set in order to bring the RT back online.
10	CLRST	W	0	Setting CLRST to logic “1” will clear the Self-Test Register
9	RAMST	W	0	Setting RAMST to logic “1” will initiate a RAM Self-Test
8	-	W	0	Reserved
7	PROST	W	0	Setting PROST to logic “1” will initiate a Protocol Self-Test
6	STOPMSG	W	0	In BC Mode, setting this bit will stop operation at End-of-Message. In MT Mode, setting this bit will stop message monitoring.
5	BCSTOPFR	W	0	In BC Mode, setting this bit will stop operation at End-of-Frame.
4	TTINC	W	0	Setting this bit will increment the Time Tag Counter by “1” LSB when Time Tag Resolution bits 9-7 of Configuration Register #2 are set to “110”.
3	TTRST	W	0	Setting TTRST to logic “1” will reset the Time Tag Counter.
2	INTRST	W	0	Setting this bit will clear Interrupt Status Registers #1 and #2.
1	BCMTSTRT	W	0	In BC Mode, setting this bit will start the BC. In MT Mode, setting this bit will start the MT.
0 (LSB)	SFTRESET	W	0	Setting this bit will initiate a software reset.

Registers and Command/Status Words

2.6. BC Control Word Register, Read/Write 0x0004

The BC Control Word is the first word in each Message Control / Status Block. The BC Control Word is not transmitted on the MIL-STD-1553 bus. This word is initialized and maintained by the host to specify message attributes such as bit masks for the received RT Status Word, which bus to use, enabling self test, BC message format, etc.

Bit No.	Mnemonic	R/W	Reset	Bit Description
15 (MSB)	TXTTMC17	R/W	0	<p>Transmit Time Tag for Synchronize (with data) Mode Code Command (MC17).</p> <p>If TXTTMC17 bit is logic “0” the BC transmits the value contained in the Message Data Block as the data word for a “synchronize” mode code command MC17.</p> <p>If TXTTMC17 bit is logic “1”, the “synchronize” mode data word value originates from the value of the Time Tag Register. Bit 5 of Configuration Register #2 must also be set.</p>
14	MEMASK	R/W	0	<p>Message Error Bit Mask.</p> <p>If MEMASK bit is logic “0” and the Message Error bit is logic 1 in the received RT Status Word, the BC will recognise the Message Error status.</p> <p>If MEMASK bit is logic “1”, the Message Error bit in the received RT Status Word is masked and is treated by the BC as “Don’t Care”.</p>
13	SRQMASK	R/W	0	<p>Service Request Bit Mask.</p> <p>If SRQMASK bit is logic “0” and the Service Request bit is logic 1 in the received RT Status Word, the BC will recognise the Service Request status.</p> <p>If SRQMASK bit is logic “1”, the Service Request bit in the received RT Status Word is masked and is treated by the BC as “Don’t Care”.</p>
12	BSYMASK	R/W	0	<p>Busy Bit Mask.</p> <p>If BSYMASK bit is logic “0” and the Busy bit is logic 1 in the received RT Status Word, the BC will recognise the Busy status.</p> <p>If BSYMASK bit is logic “1”, the Busy bit in the received RT Status Word is masked and is treated by the BC as “Don’t Care”.</p>
11	SSYSMASK	R/W	0	<p>Subsystem Flag Bit Mask.</p> <p>If SSYSMASK bit is logic “0” and the Subsystem Flag bit is logic 1 in the received RT Status Word, the BC will recognise the Subsystem Flag status.</p> <p>If SSYSMASK bit is logic “1”, the Subsystem Flag bit in the received RT Status Word is masked and is treated by the BC as “Don’t Care”.</p>

Registers and Command/Status Words

Bit No.	Mnemonic	R/W	Reset	Bit Description
10	TFMASK	R/W	0	Terminal Flag Bit Mask. If TFMASK bit is logic "0" and the Terminal Flag bit is logic 1 in the received RT Status Word, the BC will recognise the Terminal Flag status. If TFMASK bit is logic "1", the Terminal Flag bit in the received RT Status Word is masked and is treated by the BC as "Don't Care".
9	RSVMASK	R/W	0	Reserved Bits Mask. If RSVMASK bit is logic "0" and one or more of the three Reserved bits is logic "1" in the received RT Status Word, the BC will recognise the Reserved status. If RSVMASK bit is logic "1", the Reserved bits in the received RT Status Word are masked and are treated by the BC as "Don't Care".
8	RTRYENA	R/W	0	Retry Enabled. If RTRYENA is set to logic "1", failed messages will be retried according to Configuration Register settings.
7	USEBUSA	R/W	0	Use Bus A/ \bar{B} . If this Control Word bit is logic "1", the BC transmits the command on Bus A. If this Control Word bit is logic "0", the BC transmits the command on Bus B.
6	SELFTST	R/W	0	Self-Test Message Off-Line. If SELFTST is logic "1", an internal loopback test (bus transmission disabled) is performed.
5	MASKBCR	R/W	0	Mask Broadcast Command Received Bit. If MASKBCR bit is logic "0" and the Broadcast Command Received bit is logic "1" in the received RT Status Word, the BC will recognise the Broadcast status. If MASKBCR bit is logic "1", the Broadcast Command Received bit in the received RT Status Word is masked and is treated by the BC as "Don't Care".
4	EOMINT	R/W	0	End of Message Interrupt. If EOMINT is logic "1", an interrupt request will be generated (if not masked in Interrupt Enable Register #1) upon message completion.
3	1553AB	R/W	0	1553A/B Select. If 1553AB is Logic "1", RT response will comply with MIL-STD-1553A. If 1553AB is Logic "0", RT response will comply with MIL-STD-1553B.

Registers and Command/Status Words

Bit No.	Mnemonic	R/W	Reset	Bit Description			
2 – 0 (LSB)	BCMSGFT	R/W	0	BC Message Format. The BC Message format is defined by these three bits as follows:			
				Bit 2	Bit 1	Bit 0	BC Message Format
				0	0	0	BC-to-RT
				0	0	1	RT-to-RT
				0	1	0	Broadcast
				0	1	1	Broadcast RT-to-RTs
				1	0	0	Mode Code
				1	0	1	Not Used
				1	1	0	Broadcast Mode Code
				1	1	1	Not Used

2.7. RT Subaddress Control Word Register, Read/Write 0x0004

This register enables the buffering mechanism for transmit, receive and broadcast subaddresses, either globally or for individual subaddresses. It is Read-Only when the RT is active and reads back the value of the last received control word. It may be written for test purposes when the RT is Idle.

Bit No.	Mnemonic	R/W	Reset	Bit Description
15 (MSB)	DBGB	R/W	0	<p>If this bit is logic "0" then circular or single message buffering will be enabled for individual subaddresses (see MEMx bits below).</p> <p>If this bit is logic "1", then double buffering will be enabled for individual subaddresses. Note, DBUF bit 12 of Configuration Register #2 should be also be set.</p> <p>For individual subaddress buffering, enhanced RT buffering must be enabled (set ENRTBUF bit 1 of Configuration Register #2). Combinations of the MEMx bits below set the size of the buffer.</p> <p>To enable double buffering, DBUF bit 12 of Configuration Register #2 should be set.</p> <p>To enable circular buffering, CIRCEN bit 12 of Configuration Register #6 should be set.</p> <p>Note: This bit is ignored for Tx subaddresses.</p>
14	TXEOM	R/W	0	TXEOM = logic "1" enables an interrupt to be generated when the end of a message occurs for a transmit subaddress.
13	TXCIR	R/W	0	TXCIR = logic "1" enables an interrupt to be generated when a transmit subaddress circular buffer rolls over.

Registers and Command/Status Words

Bit No.	Mnemonic	R/W	Reset	Bit Description			
12 – 10	TXMEM[2:0]	R/W	0	These bits set the buffer type and size for transmit subaddress buffering as follows:			
				TXMEM2 bit 12	TXMEM1 bit 11	TXMEM0 bit 10	Buffering Mode
				0	0	0	Individual Tx subaddress single message buffering
				0	0	1	Individual Tx subaddress circular buffering, 128 Words
				0	1	0	Individual Tx subaddress circular buffering, 256 Words
				0	1	1	Individual Tx subaddress circular buffering, 512 Words
				1	0	0	Individual TX subaddress circular buffering, 1024 Words
				1	0	1	Individual TX subaddress circular buffering, 2048 Words
				1	1	0	Individual Tx subaddress circular buffering, 4096 Words
				1	1	1	Individual Tx subaddress circular buffering, 8192 Words
9	RXEOM	R/W	0	RXEOM = logic “1” enables an interrupt to be generated when the end of a message occurs for a receive subaddress.			
8	RXCIR	R/W	0	RXCIR = logic “1” enables an interrupt to be generated when a receive subaddress circular buffer rolls over.			

Registers and Command/Status Words

Bit No.	Mnemonic	R/W	Reset	Bit Description				
7 – 5	RXMEM[2:0]	R/W	0	These bits set the buffer type and size for receive subaddress buffering as follows:				
				DBGB bit 15	RXMEM2 bit 7	RXMEM1 bit 6	RXMEM0 bit 5	Buffering Mode
				0	0	0	0	Individual Rx subaddress single message buffering
				0	0	0	1	Individual Rx subaddress circular buffering, 128 Words
				0	0	1	0	Individual Rx subaddress circular buffering, 256 Words
				0	0	1	1	Individual Rx subaddress circular buffering, 512 Words
				0	1	0	0	Individual RX subaddress circular buffering, 1024 Words
				0	1	0	1	Individual RX subaddress circular buffering, 2048 Words
				0	1	1	0	Individual Rx subaddress circular buffering, 4096 Words
				0	1	1	1	Individual Rx subaddress circular buffering, 8192 Words
				1	0	0	0	Double buffering for individual Rx subaddresses.
				1	1	1	1	Global circular buffering for all Rx subaddresses. The size of the buffer is set by bits CIRSZE[11:9] of Configuration Register #6.
4	BCSTEOM	R/W	0	BCSTEOM = logic “1” enables an interrupt to be generated when the end of a message occurs for a broadcast subaddress.				
3	BCSTCIR	R/W	0	BCSTCIR = logic “1” enables an interrupt to be generated when a broadcast subaddress circular buffer rolls over.				

Registers and Command/Status Words

Bit No.	Mnemonic	R/W	Reset	Bit Description				
2 – 0	BCSTMEM[2:0]	R/W	0	These bits set the buffer type and size for broadcast subaddress buffering as follows:				
				DBGB bit 15	BCSTMEM2 bit 2	BCSTMEM1 bit 1	BCSTMEM0 bit 0	Buffering Mode
				0	0	0	0	Individual BCST subaddress single message buffering
				0	0	0	1	Individual BCST subaddress circular buffering, 128 Words
				0	0	1	0	Individual BCST subaddress circular buffering, 256 Words
				0	0	1	1	Individual BCST subaddress circular buffering, 512 Words
				0	1	0	0	Individual BCST subaddress circular buffering, 1024 Words
				0	1	0	1	Individual BCST subaddress circular buffering, 2048 Words
				0	1	1	0	Individual BCST subaddress circular buffering, 4096 Words
				0	1	1	1	Individual BCST subaddress circular buffering, 8192 Words
				1	0	0	0	Double buffering for individual BCST subaddresses.
				1	1	1	1	Global circular buffering for all BCST subaddresses. The size of the buffer is set by bits CIRSZE[11:9] of Configuration Register #6.

2.8. Time Tag Register, Read/Write 0x0005

Bit No.	R/W	Reset	Bit Description
15 (MSB) – 0 (LSB)	R/W	0	This register contains the current value of the time tag counter. The resolution of the Time Tag (in $\mu\text{s}/\text{LSB}$) is programmable through bits 9 – 7 of Configuration Register #2.

2.9. Interrupt Status Register #1, Read Only 0x0006

The bits in this register will be set when the respective event occurs, regardless of whether the interrupt is enabled (equivalent bit set in the Interrupt Enable Register #1) or not.

Bit No.	Mnemonic	R/W	Reset	Bit Description
15 (MSB)	MINT	R	0	This bit only applies when Enhanced Interrupts are enabled by setting bit 15 of Configuration Register #2. MINT will be set to logic “1” if an interrupt request has been generated on the $\overline{\text{INT}}$ output signal.
14	RAMPE	R	0	RAMPE will be set to logic “1” when a RAM parity error occurs.
13	TXTO	R	0	TXTO will be set to logic “1” when a transmitter timeout occurs.
12	STKRO	R	0	STKRO will be set to logic “1” when a command stack rollover occurs. When in BC Mode, this applies to the BC Command Stack. When in RT Mode, this applies to the RT Command Stack.
11	MTRO	R	0	MTRO will be set to logic “1” when an MT command stack rollover occurs.
10	MTDRO	R	0	MTDRO will be set to logic “1” when an MT data stack rollover occurs.
9	HSKF	R	0	HSKF will be set to logic “1” when a handshake failure occurs between the device and external RAM in Transparent Mode.
8	BCRTY	R	0	BCRTY will be set to logic “1” when the BC tries to re-send a message, regardless of whether the retry was successful or not.
7	RTAPF	R	0	RTAPF will be set to logic “1” when the RT address and parity bits do not exhibit odd parity.
6	TTRO	R	0	TTRO will be set to logic “1” when the time tag counter rolls over.
5	RTCIRRO	R	0	RTCIRRO will be set to logic “1” when the RT circular buffer rolls over.
4	CWEOM	R	0	CWEOM will be set to logic “1” at the end of the current message provided the EOM interrupt is enabled in the respective BC or RT subaddress control word.
3	BCEOF	R	0	BCEOF will be set to logic “1” at the end of the current BC frame
2	ERR	R	0	ERR will be set to logic “1” when a 1553 Message Error, loopback failure or response timeout is detected

Registers and Command/Status Words

Bit No.	Mnemonic	R/W	Reset	Bit Description	
1	BRMINT	R/W	0	The function of this bit depends on whether the device is operating in BC, RT or MT mode as follows: BRMINT will be set to logic "1" when the conditions below are met:	
				BC Mode	A received RT Status Word contains the wrong RT address or an unexpected status bit value.
				Enhanced RT Mode	A valid Mode Command is received.
				Word Monitor Mode	A valid received command word matches the value programmed in the Monitor Trigger Register.
0 (LSB)	EOM	R/W	0	EOM will be set to logic "1" at the end of every message.	

2.10. Configuration Register #3, Read/Write 0x0007

Bit No.	Mnemonic	R/W	Reset	Bit Description		
15 (MSB)	ENHANC	R/W	0	Set ENHANC to logic "1", to enable Enhanced Mode operation.		
14 – 13	BCRTSTK[1:0]	R/W	0	The BCRTSTK[1:0] bits set the size of the BC (BC Mode) or RT (RT Mode) command stack size as follows:		
				BCRTSTK 1	BCRTSTK 0	BC OR RT Command Stack Size
				0	0	256 words (64 messages)
				0	1	512 words (128 messages)
				1	0	1024 words (256 messages)
12 – 11	MTSTK[1:0]	R/W	0	The MTSTK[1:0] bits set the size of the MT command stack size as follows:		
				MTSTK 1	MTSTK 0	MT Command Stack Size
				0	0	256 words (64 messages)
				0	1	1024 words (256 messages)
				1	0	4096 words (1024 messages)
				1	1	16384 words (4096 messages)

Registers and Command/Status Words

Bit No.	Mnemonic	R/W	Reset	Bit Description			
10 – 8	MTDATA[2:0]	R/W	0	The MTDATA[2:0] bits set the size of the MT data stack size as follows:			
				MTSTK 2	MTSTK 1	MTSTK 0	MT Data Stack Size
				0	0	0	65,536 words
				0	0	1	32,768 words
				0	1	0	16,384 words
				0	1	1	8,192 words
				1	0	0	4,096 words
				1	0	1	2,048 words
				1	1	0	1,024 words
1	1	1	512 words				
7	ILLOFF	R/W	0	If ILLOFF bit is logic “0”, Command Illegalization is enabled. If ILLOFF bit is logic “1”, Command Illegalization is disabled and the Illegalization Table memory space may be used for data storage. .			
6	MCRSVME	R/W	0	The MCRSVME decides how the RT responds to a received reserved mode command: Logic “0”: RT doesn’t respond to reserved mode commands. Message Error bit is set. Logic “1”: RT will respond to reserved mode commands. Message Error bit is not set.			
5	ALTSTAT	R/W	0	Setting ALTSTAT to logic “1” enables the Alternate RT Status Word as follows: Logic “1”: All RT Status Word response bits may be controlled directly by the Host by setting their respective bits 11 – 1 in Configuration Register #1. Logic “0”: The Alternate RT Status Word is disabled and only the Dynamic Bus Control Acceptance bit, Busy bit, Service Request bit, Subsystem Flag bit and Terminal Flag bits are programmable by the Host by setting their respective bits 11 – 7 in Configuration Register #1.			
4	NOILLRX	R/W	0	If NOILLRX is set to logic “1”, illegal command data words received by the RT are not stored in RAM. If NOILLRX is set to logic “0”, illegal command data words received by the RT are stored in RAM.			
3	NOBUSYRX	R/W	0	If NOBUSYRX is set to logic “1”, the RT responds “Busy status” with the BUSY bit set, but does not store the received data words in RAM. If NOBUSYRX is set to logic “0”, the RT responds “Busy status” with the BUSY bit set and stores the received data words in RAM.			

Registers and Command/Status Words

Bit No.	Mnemonic	R/W	Reset	Bit Description
2	RTTFF	R/W	0	Active low. If RTTFF is logic "1" the Terminal Flag bit in the RT status word will be automatically set following a transmitter timeout or loopback failure and control of the Terminal Flag bit is not accessible to the host. If RTTFF is logic "0" the Terminal Flag bit in the RT status word will be automatically set following a transmitter timeout or loopback failure and the Terminal Flag bit is also programmable by the host.
1	1553A	R/W	0	If 1553A is set to logic "1", Mode Codes are processed according to MIL-STD-1553A. If 1553A is set to logic "0", Mode Codes are processed according to MIL-STD-1553B.
0 (LSB)	ENHMC	R/W	0	If ENHMC is set to logic "1", enhanced features are enabled for mode command processing. Mode code data words may be stored separately according to whether they are receive, transmit or broadcast and interrupts may be enables for individual mode codes. If ENHMC is set to logic "0", all mode code data is stored in the same location in RAM.

2.11. Configuration Register #4, Read/Write 0x0008

Bit No.	Mnemonic	R/W	Reset	Bit Description
15 (MSB)	BITW	R/W	0	If BITW is set to logic "0" the RT will respond to a Transmit BIT word mode command with the data word stored in the internal BIT Word Register. If BITW is set to logic "1" the RT will respond to a Transmit BIT word mode command with the data word stored by the host in RAM location 0x0123.
14	INBITW	R/W	0	Setting INBITW to logic "1" will inhibit transmission of the BIT word (in response to a Transmit BIT word mode command) if the Busy bit is set. The RT will respond with the Busy bit set in the RT Status word but no BIT word will be transmitted. If INBITW is logic "0", the BIT word will be transmitted (in response to a Transmit BIT word mode command), following transmission of the RT Status word with the Busy bit set.
13	MCBUSY	R/W	0	This bit affects RT response to Transmit Vector Word or the Reserved Mode Commands 22 to 31 (decimal) when the busy bit is set. If MCBUSY is logic "1" the RT will respond to the above mode commands with the busy bit set in the RT Status Word, followed by a data word. If MCBUSY is logic "0", no data word will be transmitted,

Registers and Command/Status Words

Bit No.	Mnemonic	R/W	Reset	Bit Description
12	EBCCW	R/W	0	<p>In BC Mode, setting EBCCW to logic “1” enables all bits of the Expanded BC Control Word.</p> <p>In BC Mode, if EBCCW is logic “0” or if ENHANC bit 15 in Configuration Register #3 is logic “0”, then only bits 7, 6, 5, 2, 1, and 0 in the BC Control Word are enabled.</p>
11	BCSTMEN	R/W	0	<p>In BC Mode, if BCSTMEN is logic “1”, the function of the MASKBCR bit in the BC Control Word is enabled, i.e. if BCSTMEN is logic “1” and MASKBCR bit is logic “0”, the BC will recognise Broadcast status if the Broadcast Command Received bit is logic “1” in the received RT Status Word. If MASKBCR bit is logic “1”, the Broadcast Bit in the received RT Status Word is “Don’t Care”.</p> <p>In BC Mode, if BCSTMEN is logic “0”, the value of the MASKBCR bit in the BC Control Word is XORed with the Broadcast bit in the received RT Status Word.</p>
10	RTY1553A	R/W	0	<p>Setting this bit to logic “1” will cause the BC to try to resend a message in 1553A mode when the Message Error bit in the received RT Status word is set. This is in addition to the normal criteria for retrying failed messages, provided retries are enabled (e.g. response timeout, etc.).</p>
9	RTYSTAT	R/W	0	<p>If RTYSTAT is logic “0”, the BC will not retry to send a message in response to a received RT Status Word bit being set.</p> <p>If RTYSTAT is logic “1”, the BC will retry to send a message in response to a received RT Status Word bit being set, provided retries are enabled.</p>
8	RTY1ALT	R/W	0	<p>If this bit is set to logic “0”, the first retry will be on the same bus as the original failed message.</p> <p>If this bit is set to logic “1”, the first retry will be on the opposite bus from the original failed message.</p>
7	RTY2ALT	R/W	0	<p>If this bit is set to logic “0”, the second retry will be on the same bus as the original failed message.</p> <p>If this bit is set to logic “1”, the second retry will be on the opposite bus from the original failed message.</p> <p>Note that the second retry option must be enabled by setting RTY2X, bit 3 of Configuration Register #1.</p>
6	MERVAL	R/W	0	<p>When an RT responds to a valid message with the Message Error bit set in the status word, the requested number of data words must follow the status word in order for the response to be valid.</p> <p>Setting MERVAL to logic “1” allows the message to be also valid if the status word is followed by no data words (e.g. illegal command).</p>
5	BUSYVAL	R/W	0	<p>When an RT responds to a valid message with the Busy bit bit set in the status word, the requested number of data words must follow the status word in order for the response to be valid.</p> <p>Setting BUSYVAL to logic “1” allows the message to be also valid if the status word is followed with no data words.</p>

Registers and Command/Status Words

Bit No.	Mnemonic	R/W	Reset	Bit Description																																				
4	MTGAP	R/W	0	<p>When in MT mode, this bit allows an additional 20μs to be added to the gap time of consecutive messages when the second message is received on the alternate bus.</p> <p>Logic "0": Add 20μs to gap time, even if messages overlap.</p> <p>Logic "1": Gap time will remain unchanged.</p>																																				
3	RTLATEN	R/W	0	<p>When set to logic "1", RTLATEN enables latching of the RT address and parity, provided the input signal RT_AD_LAT is also logic "1".</p> <p>When RTLATEN is logic "0", the RT address and parity will not be latched.</p>																																				
2 – 0 (LSB)	TEST[2:0]	R/W	0	<p>The TEST[2:0] bits are used to set hardware and protocol test conditions:</p> <table border="1"> <thead> <tr> <th>TEST2</th> <th>TEST1</th> <th>TEST0</th> <th>Description</th> </tr> </thead> <tbody> <tr> <td>0</td> <td>0</td> <td>0</td> <td>Normal Operation.</td> </tr> <tr> <td>0</td> <td>0</td> <td>1</td> <td>Test Decoder.</td> </tr> <tr> <td>0</td> <td>1</td> <td>0</td> <td>Test Encoder.</td> </tr> <tr> <td>0</td> <td>1</td> <td>1</td> <td>Test Protocol.</td> </tr> <tr> <td>1</td> <td>0</td> <td>0</td> <td>Test failsale timer.</td> </tr> <tr> <td>1</td> <td>0</td> <td>1</td> <td>Test Registers.</td> </tr> <tr> <td>1</td> <td>1</td> <td>0</td> <td>Reserved.</td> </tr> <tr> <td>1</td> <td>1</td> <td>1</td> <td>Not supported.</td> </tr> </tbody> </table>	TEST2	TEST1	TEST0	Description	0	0	0	Normal Operation.	0	0	1	Test Decoder.	0	1	0	Test Encoder.	0	1	1	Test Protocol.	1	0	0	Test failsale timer.	1	0	1	Test Registers.	1	1	0	Reserved.	1	1	1	Not supported.
				TEST2	TEST1	TEST0	Description																																	
				0	0	0	Normal Operation.																																	
				0	0	1	Test Decoder.																																	
				0	1	0	Test Encoder.																																	
				0	1	1	Test Protocol.																																	
				1	0	0	Test failsale timer.																																	
				1	0	1	Test Registers.																																	
				1	1	0	Reserved.																																	
1	1	1	Not supported.																																					

2.12. Configuration Register #5, Read/Write 0x0009

Bit No.	Mnemonic	R/W	Reset	Bit Description		
15 (MSB)	CLKSEL	R	0	This Read-Only bit simply returns the value of CLKSEL0, bit 0 of Configuration Register #6.		
14	SNGLEND	R	0	This bit reflects the state of the $\overline{\text{SNGLEND}}$ input signal. See the section Signal Descriptions.		
13	TXINHA	R	0	TXINHA will be logic "1" when the TX_INH_A input signal is logic "1", indicating that transmission on Bus A has been inhibited.		
12	TXINHB	R	0	TXINHB will be logic "1" when the TX_INH_B input signal is logic "1", indicating that transmission on Bus B has been inhibited.		
11	ZEROXEN	R/W	0	Setting ZEROXEN to logic "0" will cause the decoder to sample both edges of the clock input.		
10 – 9	RTRTTO[1:0]	R/W	0	These two bits set the device RT-to-RT response timeout as follows:		
				RTRTTO1	RTRTTO0	RT-to-RT Response Timeout
				0	0	18.5 μs
				0	1	22.5 μs
				1	0	50.5 μs
1	1	130 μs				
8	GTEN	R/W	0	If GTEN is set to logic "0", the device will not check for a minimum gap time between messages. If GTEN is set to logic "1", the device will check for a minimum gap time between messages of 2 μs . Violating this minimum time will result in the message being invalid.		
7	BCSTDIS	R/W	0	If BCSTDIS is set to logic "1", the device will not recognise subaddress 31 as a Broadcast Command. If BCSTDIS is set to logic "0", the device will recognise subaddress 31 as a Broadcast Command.		
6	RTADLAT	R	0	This bit reflects the state of the RT_AD_LAT input signal. See the section Signal Descriptions.		
5 – 0 (LSB)	RTAD[4:0] RTADP (LSB)	R/W	0	Writing these lower 6 bits via data lines D5 – D0 provide a mechanism to set the RT Address and Parity bit (LSB) via software. See RT_AD_LAT input signal description in section Signal Descriptions.		

Registers and Command/Status Words

2.13. RT/Monitor Data Stack Address Register, Read/Write 0x000A

Bit No.	R/W	Reset	Bit Description
15 (MSB) – 0 (LSB)	R/W	0	This register contains the current value of the Data Stack pointer, either RT Data stack or Word Monitor Data Stack, depending on the mode of operation.

2.14. BC Frame Time Remaining Register, Read Only 0x000B

Bit No.	R/W	Reset	Bit Description
15 (MSB) – 0 (LSB)	R	0	In BC Mode, this register contains the value of the time remaining in the BC frame. The resolution is 100ms/LSB, with a maximum value of 6.55ms.

2.15. BC Message Time Remaining Register, Read Only 0x000C

Bit No.	R/W	Reset	Bit Description
15 (MSB) – 0 (LSB)	R	0	In BC Mode, this register contains the current value of the time-to-next message timer. The resolution is 1 μ s/LSB, with a maximum value of 65.535ms.

2.16. Non-Enhanced BC Frame Time/Enhanced BC Initial Instruction Pointer / RT Last Command / MT Trigger Register, Read/Write 0x000D

Bit No.	R/W	Reset	Bit Description	
15 (MSB) – 0 (LSB)	R/W	0	The value of this register depends of the mode of operation as follows:	
			Mode of Operation	Register Function
			Non-Enhanced BC	Used to program the BC frame time
			Enhanced BC	Used to program the initial value of the BC instruction list pointer
			RT	Used to store the last command processed by the RT.
Word Monitor	Used to store the value of the word which will initiate a monitor start if a valid received valid word matches it.			

2.17. RT Status Word Register, Read Only 0x000E

This register contains the current value of the device RT Status Word. This includes the Alternate RT Status Word, where all lower 11 bits are all programmable by the host.

Bit No.	R/W	Reset	Bit Description
15 (MSB) – 11	R	0	Logic “0”
10	R	0	Message Error Status Bit
9	R	0	Instrumentation Status Bit
8	R	0	Service Request Status Bit
7 – 5	R	0	Reserved bits
4	R	0	Broadcast Command Received Status Bit
3	R	0	Busy Status Bit
2	R	0	Subsystem Flag Status Bit
1	R	0	Dynamic Bus Control Acceptance Status Bit
0 (LSB)	R	0	Terminal Flag Status Bit

2.18. RT BIT Word Register, Read Only 0x000F

This register’s bits will read logic “1” to reflect errors flagged by the device. The content of this register will be transmitted to the BC following a “Transmit BIT Word” mode command. It may also be read by the host.

Bit No.	Mnemonic	R/W	Reset	Bit Description
15 (MSB)	TXTO	R	0	Transmitter Timed Out. The transmitter timeout of 668 μ s was exceeded.
14	LBFB	R	0	Loopback Test Failure B. A loopback failure occurred on Bus B.
13	LBFA	R	0	Loopback Test Failure A. A loopback failure occurred on Bus A.
12	HSF	R	0	Transparent Mode Handshake Failure.
11	TXSDB	R	0	Transmitter Shutdown B. A Transmitter Shutdown mode command was received on Bus A. This mode command shuts down the transmitter of the inactive bus.
10	TXSDA	R	0	Transmitter Shutdown A. A Transmitter Shutdown mode command was received on Bus B. This mode command shuts down the transmitter of the inactive bus.

Registers and Command/Status Words

Bit No.	Mnemonic	R/W	Reset	Bit Description
9	TFINH	R	0	Terminal Flag Inhibited. An Inhibit Terminal Flag mode command was received.
8	BITF	R	0	BIT Test Fail. The device failed its internal Built-In-Test routine.
7	DWCH	R	0	Data Word Count High. The number of data words received in the last message was higher than expected.
6	DWCL	R	0	Data Word Count Low. The number of data words received in the last message was lower than expected.
5	SNYCF	R	0	Incorrect Sync Received. A command sync bit was detected in a data word.
4	INVW	R	0	Invalid Word Received
3	RTRTE	R	0	RT-to-RT Gap / Sync / Address Error. If the device is the receiving RT in an RT-to-RT transfer, this bit will be set if there is a gap time error (gap less than 2 μ s), incorrect sync or format error, or incorrect RT address.
2	RTRTTO	R	0	RT-to-RT Timeout Error. This bit will be set if the allowed RT-to-RT response time is exceeded. The RT-to-RT response timeout is programmed by setting the RTRTTO[1:0] bits [10:9] in Configuration Register #5.
1	RTRTCWE	R	0	RT-to-RT Command Word Error . If the device is the receiving RT in an RT-to-RT transfer, this bit will be set if there is an error in the Transmit Command Word, e.g. T \bar{R} bit is not logic "1".
0 (LSB)	RXCWE	R	0	Received Command Word Error. This bit will be set if there is an error in a received Command Word

2.19. Configuration Register #6, Read/Write 0x0018

Bit No.	Mnemonic	R/W	Reset	Bit Description			
15 (MSB)	ENHBC	R/W	0	Setting ENHBC to logic “1” puts the device in Enhanced BC Mode operation.			
14	ENHCPU	R/W	0	Setting ENHCPU to logic “1” reduces the wait time for the host to access the bus if a message is in progress. If ENHCPU = logic “0”, the host has to wait until the end of the entire message sequence (approximately 3.6µs for a 20MHz clock).			
13	INCSTK	R/W	0	In MT or RT modes, setting INCSTK to logic “1” will cause the command stack pointer to be incremented by 4 at EOM instead of SOM.			
12	CIRCEN	R/W	0	Setting CIRCEN to logic “1” enables the RT global circular buffer.			
11 – 9	CIRSIZE[2:0]	R/W	0	These bits are use to define the size of the global circular buffer as follows:			
				CIRSIZE2	CIRSIZE1	CIRSIZE0	Global Circular Buffer Size
				0	0	0	Circular buffering not enabled
				0	0	1	128 words
				0	1	0	256 words
				0	1	1	512 words
				1	0	0	1024 words
				1	0	1	2048 words
				1	1	0	4096 words
1	1	1	8192 words				
8	NOINVMSG	R/W	0	If NOINVMSG is set to logic “1” then invalid messages which result in interrupts will not result in any update to the Interrupt Status Queue.			
7	NOVALMSG	R/W	0	If NOVALMSG is set to logic “1” then valid messages which result in interrupts will not result in any update to the Interrupt Status Queue.			
6	INTQEN	R/W	0	Setting this bit to logic “1” will enable the Interrupt Status Queue.			

Registers and Command/Status Words

Bit No.	Mnemonic	R/W	Reset	Bit Description		
5	RTADSRC	R/W	0	<p>If RTADSRC is logic “0”, then the source of the RT address and parity will be come from the input signals RTAD[4:0] and RTADP respectively.</p> <p>If RTADSRC is logic “1”, then the source of the RT address and parity will be come from bits 5 – 0 in Configuration Register #5. See also RT_AD_LAT input signal description in section Signal Descriptions.</p>		
4	ENHMT	R/W	0	This bit affects operation when operating in combined RT/MT Mode. Setting ENHMT to logic “1” results in all command and data words being stored by the MT, including the RT status words.		
3	-	R/W	0	Reserved		
2	64WORD	R/W	0	Setting this bit to logic “1” expands the device internal register address space. As this accesses unavailable test registers, it is recommended to program this bit to logic “0”.		
1 – 0 (LSB)	CLKSEL[1:0]	R/W	0	These two bits select the Clock Frequency according to the table below.		
				CLKSEL1	CLKSEL0	Clock Frequency (MHz)
				0	0	16
				0	1	12
				1	0	20
1	1	10				

2.20. Configuration Register #7, Read/Write 0x0019

Bit No.	Mnemonic	R/W	Reset	Bit Description
15 (MSB) – 10	MEMADR	R/W	0	Memory Management Base Address, bits[15 – 10] respectively.
9 – 5	-	R/W	0	Reserved.
4	RTOFF	R/W	0	Setting this bit to logic “1” will enable the RT to go offline upon receipt of an Initiate Self-Test mode command. The host will then be able to run the built-in self-test.
3	1553RT	R/W	0	Setting this bit to logic “1” will increase the maximum time from when a host requests access to when access is granted during a DMA transfer from 8µs to 10µs.
2	ENHTT	R/W	0	This bit affects the functionality of a Synchronize With Data Mode Command. In RT Mode, if SYNCDAT bit 5 in Configuration Register #5 is logic “1”, then the data word in a Synchronize with data mode command will be loaded into the time tag register. If ENHTT is also logic “1”, then this will only happen if the LSB is “0”. In BC Mode, if SYNCDAT bit 5 in Configuration Register #5 is logic “1” and TXTTMC17 bit 15 in BC Control Word is logic “1” and ENHTT is also logic “1”, then the data word for a Synchronize with data mode command will come from the time tag register.
1	ENBCWDT	R/W	0	Setting this bit to logic “1” enables an interrupt to be generated when the BC Frame Timer expires (BCEOF will be set in the Interrupt Status Register and the interrupt will be generated if not masked by bit 3 in Interrupt Enable Register).
0 (LSB)	MCRST	R/W	0	This bit sets the functionality of the shared $\overline{\text{INCMD}}$ / $\overline{\text{MCRST}}$ digital output. If logic “0”, the output is $\overline{\text{INCMD}}$. If logic “1”, the output is $\overline{\text{MCRST}}$. See section Pin Diagrams.

Registers and Command/Status Words

2.21. BC Condition Code Register, Read Only 0x001B

Bit No.	Mnemonic	R/W	Reset	Bit Description		
15 (MSB)	ENHBC	R	0	This bit is always logic "1" in Enhanced BC Mode.		
14 – 13	RETRY[1:0]	R	0	These bits indicate the number of retries of the most recent message as follows:		
				RETRY1	RETRY0	Number of Retries
				0	0	None
				0	1	1
				1	0	Not Used
1	1	2				
12	BADMSG	R	0	This message will be logic "1" if the previous message was unsuccessful, i.e. contained errors, failed loopback or failed to elicit a response.		
11	RTSTAT	R	0	This bit will be set if any of the RT Status Word bits are set (provided they are unmasked in the BC Control Word).		
10	GOODMSG	R	0	This bit will be set to logic "1" if the previous message was error free. It will be set to zero following an invalid message.		
9	FORMERR	R	0	The bit will be set if the previous RT response had a 1553 Format Error.		
8	NORESP	R	0	This bit will be set if the BC receives no response or if the maximum response time has been exceeded.		
7 – 2	GPFLAG[7:2]	R	0	General Purpose Flags bits[7 – 2] respectively. These bits may be re-purposed for use by the host and set/reset by the BC FLG Instruction.		
1	GPFLAG1	R	0	General Purpose Flag 1. This flag may also be used as an "equal to" flag following BC compare instructions.		
0 (LSB)	GPFLAG0	R	0	General Purpose Flag 0. This flag may also be used as a "less than" flag following BC compare instructions.		

2.22. BC General Purpose Flag Register, Write Only 0x001B

Bit No.	R/W	Reset	Bit Description
15 (MSB) – 8	W	0	Clear General Purpose Flag, bits[7 – 0] respectively.
7 – 0 (LSB)	W	0	Set General Purpose Flag, bits[7 – 0] respectively.

2.23. BIT Test Status Flag Register, Read Only 0x001C

The bits in this read-only register will be set when the corresponding conditions below have occurred (except for logic “0” bits).

Bit No.	R/W	Reset	Bit Description
15 (MSB)	R	0	Protocol Built-In Test Complete
14	R	0	Protocol Built-In Test In-Progress
13	R	0	Protocol Built-In Test Passed
12	R	0	Protocol Built-In Test Abort
11	R	0	Protocol Built-In Test Complete / In-Progress
10 – 8	R	0	These bits always read Logic “0”
7	R	0	RAM Built-In Test Complete
6	R	0	RAM Built-In Test In-Progress
5	R	0	RAM Built-In Test Passed
4 – 0 (LSB)	R	0	These bits always read Logic “0”

Registers and Command/Status Words

2.24. Interrupt Enable Register #2, Read/Write 0x001D

Setting a respective bit below to logic “1” will cause an interrupt to be generated when the corresponding event occurs. The equivalent bit in Interrupt Status Register #2 will also be set to logic “1” regardless of whether the enable bit is set or not. Setting a respective bit below to logic “0” will disable (mask) the interrupt.

Bit No.	Mnemonic	R/W	Reset	Bit Description
15 (MSB)	–	R/W	0	Not Used
14	BCOPER	R/W	0	Set BCOPER to logic “1” to generate an interrupt when a parity error is detected in an Enhanced BC instruction.
13	ILLCMD	R/W	0	In RT Mode, set ILLCMD to logic “1” to generate an interrupt when an illegalized command is received. In Message Monitor Mode, set this bit to logic “1” to generate an interrupt when a message is received and stored by the monitor.
12	QUERO	R/W	0	In Enhanced BC Mode, set this bit to logic “1” to generate an interrupt when the General Purpose Queue rolls over. In RT and MT modes, set this bit to logic “1” to generate an interrupt when the Interrupt Status Queue rolls over.
11	STKERR	R/W	0	In Enhanced BC Mode, set this bit to logic “1” to generate an interrupt when the BC Call Stack overflows or underflows.
10	BCILL	R/W	0	Set BCILL to logic “1” to generate an interrupt when the Enhanced BC fetches an illegal op code.
9	RTSTK50	R/W	0	Set RTSTK50 to logic “1” to generate an interrupt when the RT Command Stack is 50% full.
8	RTCIR50	R/W	0	Set RTCIR50 to logic “1” to generate an interrupt when the RT Circular Buffer is 50% full.
7	MTSTK50	R/W	0	Set MTSTK50 to logic “1” to generate an interrupt when the MT Command Stack is 50% full.
6	MTDT50	R/W	0	Set MTD50 to logic “1” to generate an interrupt when the MT Data Stack is 50% full.
5 – 2	BCIRQ[3:0]	R/W	0	Set BCIRQ[3:0] to logic “1” to generate an interrupt when the Enhanced BC issues an IRQ instruction.
1	BIST	R/W	0	Set BIST to logic “1” to generate an interrupt when the devices completes a built-in self-test.
0 (LSB)	–	R/W	0	Not Used

2.25. Interrupt Status Register #2, Read Only 0x001E

The bits in this register will be set when the respective event occurs, regardless of whether the interrupt is enabled (equivalent bit set in the Interrupt Enable Register #2) or not.

Bit No.	Mnemonic	R/W	Reset	Bit Description
15 (MSB)	MSTINT	R	0	MSTINT will be logic "1" when one or more of the interrupts below is pending.
14	BCOPER	R	0	BCOPER will be set to logic "1" when a parity error is detected in an Enhanced BC instruction.
13	ILLCMD	R	0	In RT Mode, ILLCMD will be set to logic "1" when an illegalized command is received. In Message Monitor Mode, this bit is set to logic "1" when a message is received and stored by the monitor.
12	QUERO	R	0	In Enhanced BC Mode, QUERO will be set to logic "1" when the General Purpose Queue rolls over. In RT and MT modes, this bit will be set to logic "1" when the Interrupt Status Queue rolls over.
11	STKERR	R	0	In Enhanced BC Mode, STKERR will be set to logic "1" when the BC Call Stack overflows or underflows.
10	BCILL	R	0	BCILL will be set to logic "1" when the Enhanced BC fetches an illegal op code
9	RTSTK50	R	0	RTSTK50 will be set to logic "1" when the RT Command Stack is 50% full.
8	RTCIR50	R	0	RTCIR50 will be set to logic "1" when the RT Circular Buffer is 50% full.
7	MTSTK50	R	0	MTSTK50 will be set to logic "1" when the MT Command Stack is 50% full.
6	MTDT50	R	0	MTDT50 will be set to logic "1" when the MT Data Stack is 50% full.
5 – 2	BCIRQ[3:0]	R	0	These bits will be change when the Enhanced BC issues an IRQ instruction. The value of these bits will reflect the value of the 4 LSBs of the IRQ parameter respectively.
1	BIST	R	0	Built-in Self-Test Complete. BIST will be set to logic "1" when a protocol self-test or RAM self-test is completed.
0 (LSB)	INTSTAT1	R	0	INTSTAT1 will be set to logic "1" when one or more bits are set in Interrupt Status Register #1.

Registers and Command/Status Words

2.26. BC General Purpose Queue Pointer Register / RT, MT Interrupt Status Queue Pointer Register, Read/Write 0x001F

In Enhanced BC mode, this register contains the pointer for the General Purpose Queue. In RT and Message Monitor modes, it contains the pointer for the Interrupt Status Queue. Bits 15 – 6 contain the base address and bits 5 – 0 contain the address of the next data location.

Bit No.	R/W	Reset	Bit Description
15 (MSB) – 6	R/W	0	Queue Pointer Base Address, bits[15 – 6] respectively.
5 – 0 (LSB)	R/W	0	Queue Pointer Address, bits[5 – 0] respectively.

2.27. BC Block Status Word

The Block Status Word in the Message Control / Status Block provides information regarding message status (in process or completed), the bus it was transmitted on, whether errors occurred during the message, and the type of occurring errors. This word is written into RAM by the device after message completion. Because it resides in RAM, the host has read-write access, although this word is usually treated as read-only by the host.

Bit No.	Mnemonic	R/W	Reset	Bit Description
15 (MSB)	EOM	R/W	0	End of Message. This bit is set upon completion of a BC message, whether or not errors occurred.
14	SOM	R/W	0	Start of Message. This bit is set at the start of a BC message and cleared at the end of the message.
13	BID	R/W	0	Bus ID (Bus B / $\overline{\text{Bus A}}$). This bit is logic “1” if the BC message was transacted on Bus B. This bit is logic “0” if the BC message was transacted on Bus A.
12	EF	R/W	0	This bit acts as an Error Flag. If EF is logic “1” and some/all of bits 10, 9 or 8 are also set, it is an indication that one or more of those respective errors occurred in the current message. If EF is logic “1” and all of bits 10, 9 and 8 are zero, then a handshake failure has occurred (applies only to transparent mode).
11	STATSET	R/W	0	Status Set. This bit is not affected by the values of mask bits 14-9 in the BC Control Word for the message. This bit is logic “1” when the received RT Status Word contains an unexpected bit value in the bit range 10 – 0. The expected value is usually logic “0”, except when broadcast is enabled.

Registers and Command/Status Words

Bit No.	Mnemonic	R/W	Reset	Bit Description		
10	FE	R/W	0	Format Error. This bit is logic "1" when a received RT response violates MIL-STD-1553 message protocol. This includes sync, word count, encoding, bit count or parity errors.		
9	TOER	R/W	0	No Response Timeout Error. This bit is logic "1" when a receiving RT responded later than the RT-to-RT Response Timeout interval specified by bits RTRTTO[10 – 9] in Configuration Register #5.		
8	LBE	R/W	0	Loopback Error. Each word transmitted by the BC is looped back to the receiver and checked for 1553 validity (sync, encoding, bit count and/or parity error). In addition, for each message transacted, the received image for the last word transmitted by the BC is evaluated for data match. This bit is logic "1" when the received version for one or more words transmitted by the BC fails 1553 "word validity" criteria, and/or the received version for the last word transmitted by the BC does not match the transmitted Manchester II word.		
7	MSTATSET	R/W	0	Masked Status Set. This bit is logic "1" when one or more of the mask bits 14-9 in the BC Control Word is logic "0" and the corresponding bit is logic "1" in the received RT Status Word.		
6 – 5	RETRY[1:0]	R/W	0	These two bits indicate the number of times a message was retried:		
				RETRY1	RETRY0	Number of Retries
				0	0	0
				0	1	1
				1	0	2
1	1	2				
4	GDB	R/W	0	Good Transmit Data Block Transfer. This bit is set to logic "1" upon successful completion of an error-free RT-to-BC message, RT-to-RT message, or transmit mode code message with data. This bit always resets to logic 0 for any BC-to-RT message, mode code message without data, or any incomplete or invalid message.		

Registers and Command/Status Words

Bit No.	Mnemonic	R/W	Reset	Bit Description
3	WAG	R/W	0	<p>Wrong RT Address and/or No Gap.</p> <p>This bit is logic 1 when one or both of the following conditions occur:</p> <ul style="list-style-type: none"> the RT address field within a received RT Status Word does not match the RT address field in the Command Word transmitted by the BC or the GTEN Gap Check Enable bit 8 of Configuration Register #5 is set and the RT responds with response time less than 4 μs per MIL-STD-1553B, mid-parity bit to mid-sync, (2 μs bus “dead time”).
2	LE	R/W	0	<p>Word Count (Length) Error.</p> <p>This bit is logic 1 when an RT-to-BC message, RT-to-RT message, or transmit mode code message with data is transacted with the wrong number of data words.</p> <p>This bit always resets to logic 0 for BC-to-RT messages, receive mode code messages, or transmit mode code messages without data.</p>
1	SE	R/W	0	<p>Sync Error.</p> <p>This bit is logic 1 when an RT responds with Data Sync in its Status Word, or with Command/Status Sync in a Data Word.</p>
0 (LSB)	IWE	R/W	0	<p>Invalid Word Error.</p> <p>This bit is logic 1 when an RT response in one or more words having at least one of the following errors: sync encoding error, Manchester II encoding error, bit count error, parity error.</p>

2.28. RT and MT Block Status Word

The following block status word applies to both RT and Message Monitor Modes.

Bit No.	Mnemonic	R/W	Reset	Bit Description
15 (MSB)	EOM	R/W	0	End of Message. This bit is set upon completion of an RT message, whether or not errors occurred.
14	SOM	R/W	0	Start of Message. This bit is set at the start of an RT message and cleared at the end of the message.
13	BID	R/W	0	Bus ID (Bus B / $\overline{\text{Bus A}}$). This bit is logic "1" if the RT message was transacted on Bus B. This bit is logic "0" if the RT message was transacted on Bus A.
12	EF	R/W	0	This bit acts as an Error Flag. If EF is logic "1" and some/all of bits 10, 9 or 8 (10 and 9 in Message Monitor Mode) are also set, it is an indication that one or more of those respective errors occurred in the current message. If EF is logic "1" and all of bits 10, 9 and 8 (10 and 9 in Message Monitor Mode) are zero, then a handshake failure has occurred (applies only to transparent mode).
11	RTRTRX	R/W	0	This bit will be set in the RT Block Status Word if the device is the receiving RT in an RT-to-RT transfer. In Message Monitor Mode, this bit will be set to indicate the message was an RT-to-RT transfer.
10	FE	R/W	0	Format Error. This bit is logic "1" when a received RT response violates MIL-STD-1553 message protocol. This includes sync, word count, encoding, bit count or parity errors.
9	TOER	R/W	0	No Response Timeout Error. This bit is logic "1" when the device is the receiving RT in an RT-to-RT transfer and the transmitting RT failed to respond, or responded later than the RT-to-RT Response Timeout interval specified by bits RTRTTO[10 – 9] in Configuration Register #5.

Registers and Command/Status Words

Bit No.	Mnemonic	R/W	Reset	Bit Description
8	LBE	R/W	0	<p>Loopback Error.</p> <p>In RT Mode, this bit will be logic “1” following a loopback error, i.e. when the received version of a transmitted word fails 1553 “word validity” criteria, and/or the received version of the last word transmitted does not match the transmitted Manchester II word.</p> <p>In Message Monitor Mode, this bit will be logic “1” following receipt of a valid message. It will be logic “0” if the message was invalid.</p>
7	CIRRO	R/W	0	<p>CIRRO will be set to logic “1” if the enabled global circular buffer rolls over. This will happen if the upper boundary of the circular buffer is exceeded. If OVINV bit 11 of Configuration register #2 is set to logic “1”, the roll over will only occur following receipt of a valid message. Invalid messages will be overwritten and roll over will not occur until the next valid message.</p> <p>In Message Monitor Mode, the size of the circular buffer is set by bits MTDATA[10 – 8] in Configuration Register #3.</p>
6	ILLCMD	R/W	0	<p>In RT Mode, ILLCMD will be set to logic “1” when an illegal command is received.</p>
5	LE	R/W	0	<p>Word Count (Length) Error.</p> <p>This bit is logic 1 when an RT-to-BC message, RT-to-RT message, or transmit mode code message with data is transacted with the wrong number of data words.</p>
4	SE	R/W	0	<p>Sync Error.</p> <p>This bit is logic 1 when an RT responds with Data Sync in its Status Word, or with Command/Status Sync in a Data Word.</p>
3	IWE	R/W	0	<p>Invalid Word Error.</p> <p>This bit is logic 1 when an RT response in one or more words having at least one of the following errors: sync encoding error, Manchester II encoding error, bit count error, parity error.</p>
2	RTRTERR	R/W	0	<p>This bit is set if one of the following occurs during an RT-to-RT transfer:</p> <ul style="list-style-type: none"> the RT address of the responding RT does not match the RT address field in the Command Word the GTEN Gap Check Enable bit 8 of Configuration Register #5 is set and the RT responds with response time less than 4 μs per MIL-STD-1553B, mid-parity bit to mid-sync, (2 μs bus “dead time”) the responding RT had an invalid status word or wrong sync bit.

Registers and Command/Status Words

Bit No.	Mnemonic	R/W	Reset	Bit Description
1	RTRTERR2	R/W	0	This bit is set if the second command word in an RT-to-RT transfer had an error (e.g. wrong T/ \bar{R} bit).
0 (LSB)	CWERR	R/W	0	This bit is set if a received Command Word is undefined (violates MIL-STD-1553 rules), e.g. if broadcast is enabled (BCSTDIS bit 7 in Configuration Register #5 is set to logic "0") and a mode command not allowed to be broadcast under 1553 rules (e.g. Transmit Last Command) is sent to subaddress 31.

2.29. Word Monitor Identification Word

The Word Monitor Information Word gives information about the received words stored during Word Monitor Mode operation.

Bit No.	Mnemonic	Bit Description
15 (MSB) – 8	GT[7:0]	Gap Time, bits 7 – 0. If CTDATA, bit 1 is logic "0", then these bits will show the gap time between the start of the current word and the end of the previous word. The resolution is 0.5 μ s/LSB, up to a max of 127.5 μ s.
7	WF	Word Flag, always set to logic "1".
6	RTCMD	If BCST is logic "0", then the received word was a valid RT command (correct sync, RT Address and Parity). Otherwise, RTCMD will be logic "1".
5	BCST	If BCST is logic "0", then the received word was a valid broadcast command with RT address = 31.
4	ERR	This bit will be set to logic "1" if the received word contained an error.
3	SYNC	If SYNC = logic "1", then the received word contained a command sync. If SYNC = logic "0", then the received word contained a data sync.
2	BUSAB	If BUSAB = logic "0", then the word was received on Bus A. If BUSAB = logic "1", then the word was received on Bus B.
1	CTDATA	If CTDATA is logic "1", then previous and next message is contiguous and the gap time bits GT[7:0] above are not used. If CTDATA is logic "0", then the gap time is stored in bits 15 – 8 above.
0 (LSB)	MCODE	If MCODE is logic "0", then the received word was a valid mode code command.

Registers and Command/Status Words

2.30. RT/MT Interrupt Status Queue Word

In Enhanced RT or MT Modes, or combined RT/MT Mode, both the RT and MT have the capability to store interrupt information in the Interrupt Status Queue. A two-word entry is written to the Interrupt Status Queue every time an interrupt event occurs. The first word is the Status Queue Word (see Table 7 and Table 8 below), which describe what event(s) caused the interrupt. Bit 0 will indicate if the interrupt was a message interrupt (bit 0 = logic “1”) or a non-message interrupt (bit 0 = logic “0”) event. A logic “1” value on any of the other bits indicates that respective interrupt event took place.

The second word stored in the status queue will be a parameter word, indicating where the interrupt came from, e.g. in the case of a Message Interrupt Event, the parameter word will be a pointer to the relevant Block Status Word in the RT or MT descriptor stack.

Table 7. RT/Monitor Interrupt Status Queue Word for Message Interrupt Events

Bit No.	Message Interrupt Event	Parameter Word
15 (MSB)	RT transmitter watchdog timer has timed out.	RT Block Status Word pointer
14	In RT Mode, this bit is set when an illegalized command has been received. In MT Mode, this bit is set when a valid message is received. Note: Bit 7, NOVALMSG of Configuration Register #6 must be logic “0” or this bit will not be set when a valid message is received.	RT/MT Block Status Word pointer
13	The Monitor Data Stack is half-full.	MT Block Status Word pointer
12	The Monitor Data Stack is full and has rolled over.	MT Block Status Word pointer
11	The RT Circular Buffer is half full.	RT Block Status Word pointer
10	The RT Circular Buffer is full and has rolled over.	RT Block Status Word pointer
9	The Monitor Command Stack is half-full.	MT Block Status Word pointer
8	The Monitor Command Stack is full and has rolled over.	MT Block Status Word pointer
7	The RT Command Stack is half-full.	RT Block Status Word pointer
6	The RT Command Stack is full and has rolled over.	RT Block Status Word pointer
5	A Handshake Failure occurred between the device and external RAM in Transparent Mode.	RT Block Status Word pointer
4	A 1553 Message Error, loopback failure or response timeout was detected	RT/MT Block Status Word pointer
3	A Mode Command has been received. Note: The mode command must have its interrupt enabled in the Mode Command Interrupt Enable Lookup Table at addresses 0x108 to 0x10F.	RT Block Status Word pointer

Registers and Command/Status Words

Bit No.	Message Interrupt Event	Parameter Word
2	An EOM occurred in a specific RT Subaddress Control Word. Note: The RT must be in Enhanced Memory Management Mode and the appropriate EOM interrupt bit (TXEOM, RXEOM or BCSTEOM) must be set in the RT Subaddress Control Word Register.	RT Block Status Word pointer
1	A message was completed (EOM).	RT/MT Block Status Word pointer
0 (LSB)	Logic "1".	N/A.

Table 8. RT/Monitor Interrupt Status Queue Word for non-Message Interrupt Events

A logic "1" value on any of the bits indicates that respective interrupt event took place.

Bit No.	Non-Message Interrupt Event	Parameter Word
15 (MSB) – 5	No function.	No function.
4	The Time Tag Register value rolled over.	0x0000
3	An RT Address Parity Error occurred.	0x0000
2	A Protocol Self-Test was completed.	0x0000
1	A RAM Parity Error occurred.	Address location where parity error occurred.
0 (LSB)	Logic "0".	N/A.

Pin Diagrams

3. Pin Diagrams

Bottom View

DNC	DNC	DNC	nMSTCLR	RT_AD LAT	RTAD0	RTAD3	RTAD1	RTADP	D6	D4	D8	D12	D10	nINT	DNC	DNC	DNC	18
DNC	DNC	DNC	16/n8 /nDTREQ	nINCMD	TRIG_SEL /n MEM- ENA_IN	+3.3V LOGIC	+3.3V LOGIC	D0	D2	D5	D3	D7	D11	TRANS /nBUFF	DNC	DNC	DNC	17
DNC	DNC	DNC	DNC	DNC	DNC	+3.3V LOGIC	+3.3V LOGIC	D1	RTAD2	DNC	DNC	D9	D13	D15	DNC	DNC	DNC	16
DNC	DNC	DNC	DNC	DNC	DNC	DNC	DNC	DNC	RTAD4	DNC	DNC	D14	DNC	DNC	A10	nREADYD	nIOEN	15
DNC	DNC	DNC	DNC	DNC	DNC	DNC	RSTBITEN	DNC	DNC	DNC	DNC	TAG_ CLK	DNC	n SINGL_END /DNC	DNC	TX_ INH_B	TX_ INH_A	14
DNC	GND	GND	GND	+3.3V LOGIC	+3.3V LOGIC	DNC	DNC	DNC	DNC	DNC	DNC	DNC	DNC	DNC	DNC	DNC	DNC	13
DNC	GND	GND	GND	+3.3V LOGIC	+3.3V LOGIC	DNC	DNC	DNC	DNC	GND	GND	GND	GND	DNC	A5	nSELECT	nSTRBD	12
DNC	GND	GND	GND	DNC	DNC	DNC	DNC	DNC	DNC	GND	GND	GND	GND	nMCRST	DNC	RD / nWR	A15 ¹ or A15 / CLK_ SEL_1 ²	11
DNC	ADDR_LAT /nMEMOE	CLOCK _IN	RXDATA _IN_B	n RXDATA _IN_B	DNC	DNC	DNC	DNC	DNC	GND	GND	GND	GND	A8	A9	A13 ¹ or A13 / Logic *1-2	A12 ¹ or A12 / nRE- BOOT ²	10
A6	DNC	DNC	RXDATA _OUT_B	n RXDATA _OUT_B	DNC	DNC	DNC	DNC	DNC	DNC	DNC	DNC	A3	A7	A2	+3.3V_ LOGIC	+3.3V_ LOGIC	9
POL_SEL /nDTACK	A1	nZERO- WAIT /nMEMWR	nSSFLAG /EXT_TRIG	DNC	TXINH _OUT_B	n TXDATA _OUT_B	TXDATA _OUT_B	DNC	DNC	RXDATA _IN_A	n RXDATA _IN_A	A0	TXINH _OUT_A	n TXDATA _OUT_A	TXDATA _OUT_A	+3.3V_ LOGIC	+3.3V_ LOGIC	8
+3.3V_ LOGIC	+3.3V_ LOGIC	+3.3V_ LOGIC	+3.3V_ LOGIC	DNC	TXINH _IN_B	n TXDATA _IN_B	TXDATA _IN_B	DNC	DNC	RXDATA _OUT_A	n RXDATA _OUT_A	UPADDR- EN	TXINH _IN_A	n TXDATA _IN_A	TXDATA _IN_A	A4	A14 ¹ or A14 / CLK_ SEL_0 ²	7
+3.3V_ LOGIC	+3.3V_ LOGIC	+3.3V_ LOGIC	+3.3V_ LOGIC	DNC	DNC	DNC	DNC	DNC	DNC	DNC	DNC	DNC	A11	DNC	DNC	MSB/LSB /nDTGRT	MEM / nREG	6
+3.3V_ XCVR	+3.3V_ XCVR	DNC	DNC	GND	GND	GND	GND	+3.3V_ XCVR	+3.3V_ XCVR	DNC	GND	GND	GND	GND	DNC	+3.3V_ XCVR	+3.3V_ XCVR	5
+3.3V_ XCVR	+3.3V_ XCVR	DNC	SLEEPIN	GND	GND	GND	GND	+3.3V_ XCVR	+3.3V_ XCVR	DNC	GND	GND	GND	GND	DNC	+3.3V_ XCVR	+3.3V_ XCVR	4
DNC	DNC	DNC	DNC	GND	GND	GND	GND	+3.3V_ XCVR	+3.3V_ XCVR	DNC	GND	GND	GND	GND	DNC	DNC	DNC	3
DNC	DNC	DNC	n TX/RX- B	n TX/RX- B	GND	TX/RX- B	TX/RX- B	+3.3V_ XCVR	+3.3V_ XCVR	n TX/RX- A	n TX/RX- A	GND	TX/RX- A	TX/RX- A	DNC	DNC	DNC	2
DNC	DNC	DNC	n TX/RX- B	n TX/RX- B	GND	TX/RX- B	TX/RX- B	+3.3V_ XCVR	+3.3V_ XCVR	n TX/RX- A	n TX/RX- A	GND	TX/RX- A	TX/RX- A	DNC	DNC	DNC	1
V	U	T	R	P	N	M	L	K	J	H	G	F	E	D	C	B	A	

Notes:

1. 64K RAM option.
2. 4K RAM option.
3. Prefix "n" denotes an inverted or negative signal, e.g. nRXDATA_IN_A = $\overline{\text{RXDATA_IN_A}}$, etc.

Figure 1. HI-621x3PBx (3.3V Transceiver) BGA Package Pinout

Bottom View

DNC	DNC	DNC	DNC	DNC	DNC	RSTBITEN	RT_AD_LAT	RTAD1	RTADP	D2	D6	D8	D12	TAG_CLK	DNC	DNC	DNC	18
DNC	DNC	DNC	DNC	DNC	DNC	DNC	RTAD2	RTAD3	D1	D0	D4	D7	D14	nINT	DNC	DNC	DNC	17
DNC	DNC	DNC	DNC	DNC	DNC	DNC	+5.0V / +3.3V_LOGIC	RTAD0	RTAD4	nINCMD	D5	D10	D13	TRANS / nBUFF	DNC	DNC	DNC	16
n TX/RX-B	n TX/RX-B	GND	GND	GND	DNC	DNC	+5.0V / +3.3V_LOGIC	DNC	DNC	DNC	D3	D9	D11	D15	nREADYD	DNC	n SNGL_END	15
n TX/RX-B	GND	GND	GND	GND	RXDATA_OUT_B	n RXDATA_OUT_B	DNC	DNC	DNC	GND	GND	GND	GND	DNC	nIOEN	DNC	TX_INH_A	14
+5.0V_XCVR	+5.0V_XCVR	GND	GND	GND	RXDATA_IN_B	n RXDATA_IN_B	DNC	DNC	DNC	GND	GND	GND	GND	DNC	TX_INH_B	nMCRST	nVDD_LOW	13
TX/RX-B	GND	GND	GND	GND	n TXDATA_IN_B	n TXDATA_OUT_B	DNC	DNC	DNC	GND	GND	GND	GND	DNC	UPADDR-EN	nSELECT	nSTRBD	12
TX/RX-B	TX/RX-B	GND	GND	GND	DNC	DNC	TRIG_SEL / n MEM-ENA IN	DNC	DNC	DNC	DNC	DNC	DNC	DNC	MEM / nREG	nMSTCLR	RD / nWR	11
DNC	DNC	DNC	TXDATA_IN_B	TXDATA_OUT_B	DNC	nZERO-WAIT / nMEMWR	16/n8 / nDTREQ	DNC	DNC	DNC	DNC	A0	n RXDATA_OUT_A	n RXDATA_IN_A	A15 ¹ or A15 / CLK_SEL ^{1,2}	A13 ¹ or A13 / Logic ^{1,2}	A14 ¹ or A14 / CLK_SEL ^{0,2}	10
DNC	DNC	DNC	+5.0V / +3.3V_LOGIC	+5.0V / +3.3V_LOGIC	POL_SEL / nDTACK	CLOCK_IN	ADDR_LAT / nMEMOE	DNC	DNC	DNC	DNC	RXDATA_OUT_A	RXDATA_IN_A	DNC	A8	A11	A12 ¹ or A12 / nRE-BOOT ²	9
+5.0V / +3.3V_LOGIC	DNC	TXINH_IN_B	TXINH_OUT_B	DNC	DNC	DNC	DNC	DNC	nSSFLAG / EXT_TRIG	DNC	DNC	DNC	A2	A4	TXDATA_IN_A	TXDATA_OUT_A	A10	8
DNC	DNC	DNC	DNC	+5.0V / +3.3V_LOGIC	DNC	DNC	DNC	DNC	MSB/LSB / nDTGRT	DNC	DNC	DNC	A1	A6	A7	A9	+5.0V / +3.3V_LOGIC	7
DNC	DNC	DNC	DNC	DNC	DNC	DNC	DNC	DNC	DNC	DNC	DNC	DNC	DNC	A3	A5	DNC	DNC	6
DNC	DNC	DNC	DNC	DNC	DNC	DNC	DNC	DNC	DNC	GND	GND	GND	GND	GND	n TXDATA_OUT_A	DNC	TXINH_OUT_A	5
DNC	DNC	DNC	+5.0V_RAM ¹ or DNC ²	+5.0V_RAM ¹ or DNC ²	DNC	DNC	DNC	DNC	DNC	GND	GND	GND	GND	GND	n TXDATA_IN_A	DNC	TXINH_IN_A	4
DNC	DNC	DNC	DNC	DNC	DNC	+5.0V / +3.3V_LOGIC	DNC	DNC	DNC	GND	GND	GND	GND	GND	DNC	DNC	DNC	3
DNC	DNC	DNC	DNC	DNC	DNC	DNC	+5.0V / +3.3V_LOGIC	DNC	DNC	n TX/RX-A	GND	+5.0V_XCVR	GND	TX/RX-A	DNC	DNC	DNC	2
DNC	DNC	DNC	DNC	DNC	DNC	DNC	+5.0V / +3.3V_LOGIC	DNC	DNC	n TX/RX-A	n TX/RX-A	+5.0V_XCVR	TX/RX-A	TX/RX-A	DNC	DNC	DNC	1
V	U	T	R	P	N	M	L	K	J	H	G	F	E	D	C	B	A	

Notes:

1. 64K RAM option.
2. 4K RAM option.
3. Prefix "n" denotes an inverted or negative signal, e.g. nRXDATA_IN_A = $\overline{\text{RXDATA_IN_A}}$, etc.

Figure 2. HI-621x5PBx and HI-62106PBx, (5.0V Transceiver) BGA Package Pinout

Pin Diagrams

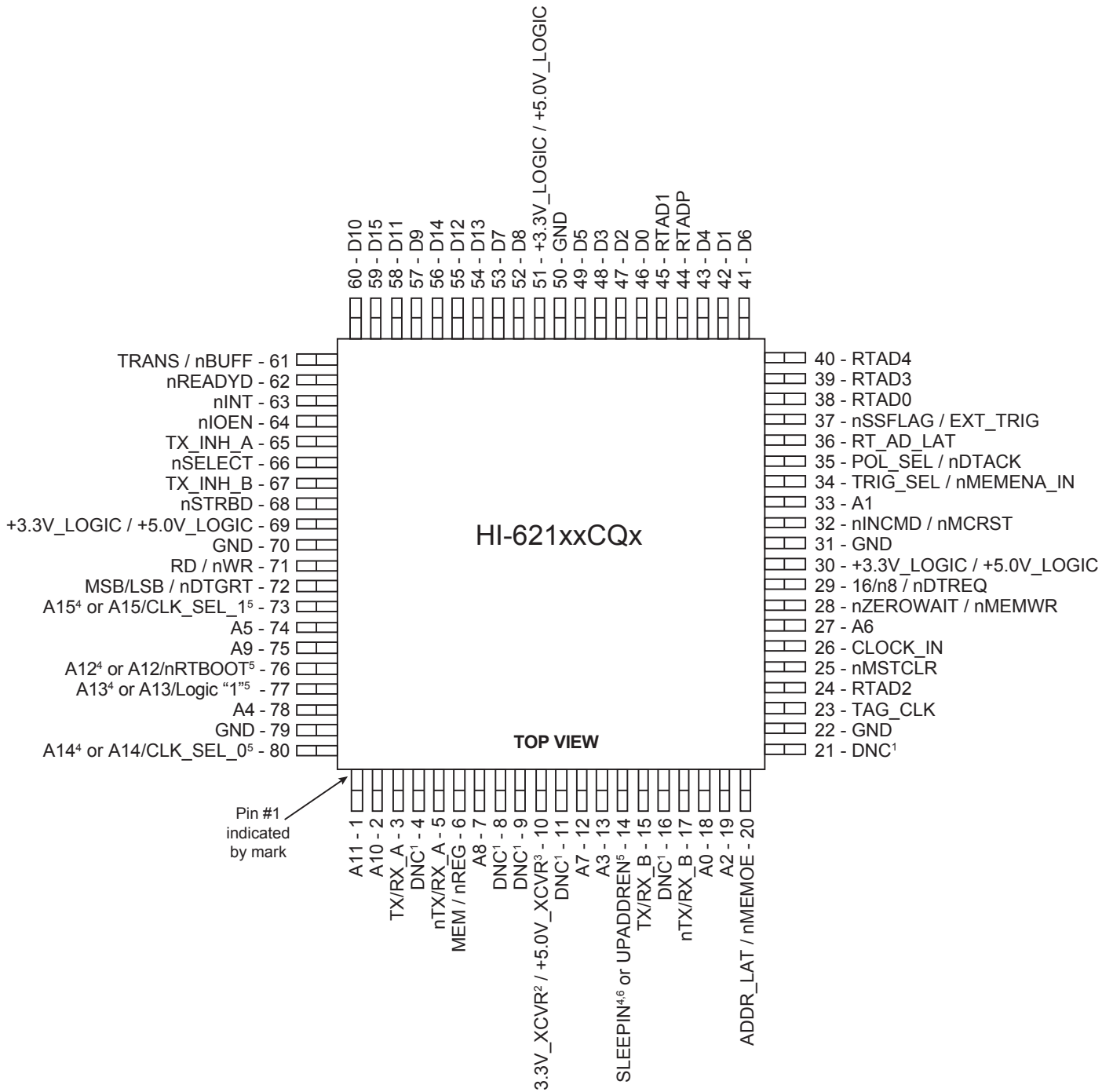

Notes:

1. Do Not Connect (Factory test pin).
2. HI-621x3CQx and HI-621x4CQx.
3. HI-621x5CQx.
4. 64K RAM option.
5. 4K RAM option.
6. Connecting the SLEEPIN pin has no effect.
7. Prefix "n" denotes an inverted or negative signal, e.g. nMSTCLR = MSTCLR, etc.

Figure 3. HI-621xxCx Gull Wing or Flat Pack Package Pinouts (All Variants)

4. Signal Descriptions – Ball Grid Array Packages

Table 9. Power and Ground

Ball Name	Function	Description
DNC	Do Not Connect	These balls MUST be left unconnected.
+3.3V_XCVR	Power Supply	+3.3V DC power supply for bus transceiver ¹ .
+3.3V_LOGIC	Power Supply	+3.3V DC power supply for digital logic ¹ .
+5.0V_XCVR	Power Supply	+5.0V DC power supply for bus transceiver ² .
+ 5.0V / + 3.3V_LOGIC	Power Supply	+5.0V or +3.3V DC power supply for digital logic ³ .
+ 5.0V_RAM	–	Connecting this input has no effect. RAM supply connected internally on-chip. (Applies to HI-62105PBx only).
GND	Power Supply	Power supply ground.
$\overline{\text{VDD_LOW}}$	–	Connecting this input has no effect.

Notes

1. HI-621x3PBx only.
2. HI-621x5PBx or HI-62106PBx only.
3. These balls support both 3.3V or 5V logic supplies (HI-621x5PBx or HI-62106PBx only).

Table 10. MIL-STD-1553 Bus Interface

Signal Name	Function	Description
TX/RX-A	Analog I/O	Bi-directional Bus A interface to external MIL-STD-1553 isolation transformer. Observe positive / negative polarity.
$\overline{\text{TX/RX-A}}$	Analog I/O	
TX/RX-B	Analog I/O	Bi-directional Bus B interface to external MIL-STD-1553 isolation transformer. Observe positive / negative polarity.
$\overline{\text{TX/RX-B}}$	Analog I/O	

Signal Descriptions – Ball Grid Array Packages

Table 11. External Transceiver Interface

Important Note: When using the integrated internal transceivers, the connections outlined in the table below are **mandatory**.

Signal Name	Function	Description
$\overline{\text{SNGL_END}}$	Digital Input	This signal should be left unconnected to use device internal transceivers. When using external transceivers, this input controls whether the Manchester decoder inputs accepts single-ended or double-ended input signals. For standard MIL-STD-1553 double-ended bi-phase operation, this signal should be connected to logic "1". For single-ended, connect to logic "0".
TXINH_IN_A	Digital Input	These two signals must be tied together when using device internal transceivers. For external transceiver operation, connect output TXINH_OUT_A to TXINH input of external MIL-STD-1553 transceiver. Transmission on Bus A will be inhibited when asserted high. The TXINH_IN_A input may be left floating (internal pull-up).
TXINH_OUT_A	Digital Output	
TXDATA_IN_A	Digital Input	These two signals must be tied together when using device internal transceivers. For external transceiver operation, connect output TXDATA_OUT_A to the equivalent input of a MIL-STD-1553 transceiver. TXDATA_IN_A is not used and may be left floating (internal pull-up).
TXDATA_OUT_A	Digital Output	
$\overline{\text{TXDATA_IN_A}}$	Digital Input	These two signals must be tied together when using device internal transceivers. For external transceiver operation, connect output $\overline{\text{TXDATA_OUT_A}}$ to the equivalent input of a MIL-STD-1553 transceiver. $\overline{\text{TXDATA_IN_A}}$ is not used and may be left floating (internal pull-up).
$\overline{\text{TXDATA_OUT_A}}$	Digital Output	
$\overline{\text{RXDATA_IN_A}}$	Digital Input	These two signals must be tied together when using device internal transceivers. For external transceiver operation, connect input, $\overline{\text{RXDATA_IN_A}}$ to the equivalent output of a MIL-STD-1553 transceiver. $\overline{\text{RXDATA_OUT_A}}$ is not used and may be left floating (internal pull-up).
$\overline{\text{RXDATA_OUT_A}}$	Digital Output	
RXDATA_IN_A	Digital Input	These two signals must be tied together when using device internal transceivers. For external transceiver operation, connect input RXDATA_IN_A to the equivalent output of a MIL-STD-1553 transceiver. RXDATA_OUT_A is not used and may be left floating (internal pull-up).
RXDATA_OUT_A	Digital Output	
TXINH_IN_B	Digital Input	These two signals must be tied together when using device internal transceivers. For external transceiver operation, connect output TXINH_OUT_B to TXINH input of external MIL-STD-1553 transceiver. Transmission on Bus B will be inhibited when asserted high. TXINH_IN_B input may be left floating (internal pull-up).
TXINH_OUT_B	Digital Output	
TXDATA_IN_B	Digital Input	These two signals must be tied together when using device internal transceivers. For external transceiver operation, connect output TXDATA_OUT_B to the equivalent input of a MIL-STD-1553 transceiver. TXDATA_IN_B is not used and may be left floating (internal pull-up).
TXDATA_OUT_B	Digital Output	
$\overline{\text{TXDATA_IN_B}}$	Digital Input	These two signals must be tied together when using device internal transceivers. For external transceiver operation, connect output $\overline{\text{TXDATA_OUT_B}}$ to the equivalent input of a MIL-STD-1553 transceiver. $\overline{\text{TXDATA_IN_B}}$ is not used and may be left floating (internal pull-up).
$\overline{\text{TXDATA_OUT_B}}$	Digital Output	

Signal Descriptions – Ball Grid Array Packages

Signal Name	Function	Description
$\overline{\text{RXDATA_IN_B}}$	Digital Input	These two signals must be tied together when using device internal transceivers. For external transceiver operation, connect input $\overline{\text{RXDATA_IN_B}}$ to the equivalent output of a MIL-STD-1553 transceiver. $\overline{\text{RXDATA_OUT_B}}$ is not used and may be left floating (internal pull-up).
$\overline{\text{RXDATA_OUT_B}}$	Digital Output	
RXDATA_IN_B	Digital Input	These two signals must be tied together when using device internal transceivers. For external transceiver operation, connect input RXDATA_IN_B to the equivalent output of a MIL-STD-1553 transceiver. RXDATA_OUT_B is not used and may be left floating (internal pull-up).
RXDATA_OUT_B	Digital Output	

Signal Descriptions – Ball Grid Array Packages

Table 12. Host Address and Data Buses

Signal Name	Function	Description																					
D15 (MSB) – D0 (LSB)	Data inputs or Data outputs	Bi-directional data bus for host read/write operations on registers and RAM.																					
A15 (MSB) – A0 (LSB)	Digital inputs	For 64K RAM devices these signals function as the address bus for host read/write operations on registers and RAM.																					
A15 / CLK_SEL_1 and A14 / CLK_SEL_0	Digital Input	For 4K RAM devices, the function of these signals depends on the value of UPADDREN.																					
		<table border="1"> <tr> <td>If UPADDREN = Logic "1", these signals are address lines.</td> <td colspan="3">If UPADDREN = Logic "0", these signals function as CLK_SEL_1 and CLK_SEL_0 and set the clock frequency as follows:</td> </tr> <tr> <td></td> <td>CLK_SEL_1</td> <td>CLK_SEL_0</td> <td>Clock Frequency</td> </tr> <tr> <td rowspan="4">A15 – A14</td> <td>0</td> <td>0</td> <td>10 MHz</td> </tr> <tr> <td>0</td> <td>1</td> <td>20 MHz</td> </tr> <tr> <td>1</td> <td>0</td> <td>12 MHz</td> </tr> <tr> <td>1</td> <td>1</td> <td>16 MHz</td> </tr> </table>	If UPADDREN = Logic "1" , these signals are address lines.	If UPADDREN = Logic "0" , these signals function as CLK_SEL_1 and CLK_SEL_0 and set the clock frequency as follows:				CLK_SEL_1	CLK_SEL_0	Clock Frequency	A15 – A14	0	0	10 MHz	0	1	20 MHz	1	0	12 MHz	1	1	16 MHz
		If UPADDREN = Logic "1" , these signals are address lines.	If UPADDREN = Logic "0" , these signals function as CLK_SEL_1 and CLK_SEL_0 and set the clock frequency as follows:																				
			CLK_SEL_1	CLK_SEL_0	Clock Frequency																		
		A15 – A14	0	0	10 MHz																		
0	1		20 MHz																				
1	0		12 MHz																				
1	1		16 MHz																				
A13 / LOGIC "1"	Digital Input	<p>For 4K RAM devices, the function of this signal depends on the value of UPADDREN.</p> <p>If UPADDREN = Logic "1", this signal functions as address line A13.</p> <p>If UPADDREN = Logic "0", this signal MUST be connected to +V_LOGIC.</p> <p>Note: If UPADDREN = logic "0" AND TAG_CLK = logic "0", then connecting this signal to logic "0" will configure certain device options as an RT-only with DMA interface. This may be used as an RT-only interface to a system without a microprocessor. See "Operation in RT-only Mode with DMA Interface".</p>																					
A12 / $\overline{\text{RTBOOT}}$	Digital Input	For 4K RAM devices, the function of this signal depends on the value of UPADDREN.																					
		<table border="1"> <tr> <td>If UPADDREN = Logic "1", this signal functions as address line A12.</td> <td colspan="2">If UPADDREN = Logic "0", this signal functions as $\overline{\text{RTBOOT}}$. as follows:</td> </tr> <tr> <td></td> <td>$\overline{\text{RTBOOT}}$ = Logic "1"</td> <td>$\overline{\text{RTBOOT}}$ = Logic "0"</td> </tr> <tr> <td></td> <td>For an RT-only device, the device will initialize in Idle mode. For a BC/RT/MT device, the device will initialize in BC mode.</td> <td>Enable MIL-STD-1760 operation (the RT will initialize with the busy bit set in the RT Status Word).</td> </tr> </table>	If UPADDREN = Logic "1" , this signal functions as address line A12.	If UPADDREN = Logic "0" , this signal functions as $\overline{\text{RTBOOT}}$. as follows:			$\overline{\text{RTBOOT}}$ = Logic "1"	$\overline{\text{RTBOOT}}$ = Logic "0"		For an RT-only device, the device will initialize in Idle mode. For a BC/RT/MT device, the device will initialize in BC mode.	Enable MIL-STD-1760 operation (the RT will initialize with the busy bit set in the RT Status Word).												
If UPADDREN = Logic "1" , this signal functions as address line A12.	If UPADDREN = Logic "0" , this signal functions as $\overline{\text{RTBOOT}}$. as follows:																						
	$\overline{\text{RTBOOT}}$ = Logic "1"	$\overline{\text{RTBOOT}}$ = Logic "0"																					
	For an RT-only device, the device will initialize in Idle mode. For a BC/RT/MT device, the device will initialize in BC mode.	Enable MIL-STD-1760 operation (the RT will initialize with the busy bit set in the RT Status Word).																					
A11 – A0 (LSB)	Digital Input	Lower 12 bits of 16-bit bi-directional address bus.																					

Signal Descriptions – Ball Grid Array Packages

Table 13. Host Interface

Signal Name	Function	Description
$\overline{\text{SELECT}}$	Digital Input	The Host sets this signal to logic "0" to select the device for a transfer to / from RAM (or registers).
$\overline{\text{STRBD}}$	Digital Input	This signal is used by the host with the $\overline{\text{SELECT}}$ signal to initiate data transfers to / from the device. $\overline{\text{STRBD}}$ must remain low during the data transfer cycle.
RD / $\overline{\text{WR}}$	Digital Input	Read/Write. RD/ $\overline{\text{WR}}$ specifies reading or writing between the host. The polarity depends on the state of the POL_SEL signal (see below).
ADDR_LAT or $\overline{\text{MEMOE}}$	Digital Input or Digital Output	When in buffered mode, this signal is an input and functions as ADDR_LAT. When ADDR_LAT transitions low, it latches the values on A15 – A0, $\overline{\text{SELECT}}$, MEM / $\overline{\text{REG}}$, and MSB / LSB. When ADDR_LAT is high, the values of these signals track the respective inputs. When in transparent mode, this signal is an output and functions as $\overline{\text{MEMOE}}$. It is used to enable external RAM reads and should be connected to the $\overline{\text{OE}}$ input signal on an external RAM.
$\overline{\text{ZEROWAIT}}$ or $\overline{\text{MEMWR}}$	Digital Input or Digital Output	When in buffered mode, this signal is an input and functions as $\overline{\text{ZEROWAIT}}$ as follows; $\overline{\text{ZEROWAIT}} = "0"$ specifies zero wait mode, $\overline{\text{ZEROWAIT}} = "1"$ specifies non-zero wait mode. When in transparent mode, this signal is an output and functions as $\overline{\text{MEMWR}}$. It is used in transparent mode for external RAM data transfers and should be connected to the $\overline{\text{WR}}$ input signal on the external RAM.
16 / $\overline{8}$ or $\overline{\text{DTREQ}}$	Digital Input or Digital Output	When in buffered mode, this signal is an input and functions as 16 / $\overline{8}$. It is used to specify 16 bit data mode (16 / $\overline{8} = "1"$) or 8-bit data mode (16 / $\overline{8} = "0"$). When in transparent mode, this signal is an output and functions as $\overline{\text{DTREQ}}$ (Data Transfer Request). It is used by the device to request access to the host address and data buses. The handshake is complete when the $\overline{\text{DTGRT}}$ (Data Transfer Grant) signal is asserted in response.
MSB / LSB or $\overline{\text{DTGRT}}$	Digital Input or Digital Input	When in buffered mode (8-bit only), this signal is an input and functions as (MSB / LSB). It is used to indicate whether the MSB or LSB is currently being transferred. The polarity of MSB / LSB is controlled by the POL_SEL input (see below). When in transparent mode, this signal is an input and functions as the $\overline{\text{DTGRT}}$ signal. It completes the handshake following a $\overline{\text{DTREQ}}$ request and is asserted to indicate that control of the host address and data buses have been released to the device.

Signal Descriptions – Ball Grid Array Packages

Signal Name	Function	Description		
POL_SEL	Digital Input	Polarity Select or Data Transfer Bus Acknowledge. When in buffered mode, this signal is an input and functions as POL_SEL. In 16-bit mode, it controls the polarity of the RD / \overline{WR} signal and in 8-bit mode it controls the polarity of the MSB / LSB signal as follows:		
		POL_SEL	16-bit buffered mode	8-bit-buffered mode
		1	Assert RD / \overline{WR} = 1 for RD. Assert RD / \overline{WR} = 0 for WR.	Assert MSB / LSB = 1 for LSB. Assert MSB / LSB = 0 for MSB.
		0	Assert RD / \overline{WR} = 0 for RD. Assert RD / \overline{WR} = 1 for WR.	Assert MSB / LSB = 0 for LSB. Assert MSB / LSB = 1 for MSB.
\overline{DTACK}	Digital Output	When in transparent mode, this signal is an output and functions as \overline{DTACK} . It is asserted to acknowledge a data transfer grant (\overline{DTGRT}) and indicates that the device has accepted control of the host address and data buses.		
TRIG_SEL	Digital Input	In 8-bit buffered mode, this signal is an input and functions as TRIG-SEL. It is used to select the "endianness" (byte order) of 16-bit word transfers to or from the device as follows:		
		TRIG_SEL	8-bit buffered mode	16-bit buffered mode
		1	MSB followed by LSB.	No function. May be left unconnected.
		0	LSB followed by MSB.	No function. May be left unconnected.
$\overline{MEMENA_IN}$	Digital Input	When in transparent mode, this signal is an input and functions as $\overline{MEMENA_IN}$. It is used as a Chip Select input to the internal RAM. NOTE: If only internal RAM is used, $\overline{MEMENA_IN}$ should be connected directly to the output of a OR Gate which has \overline{DTACK} and \overline{IOEN} as inputs.		
MEM/ \overline{REG}	Digital Input	This input is used by the host to notify the device of memory or register access. MEM / \overline{REG} = "1" for memory access or MEM / \overline{REG} = "0" for register access.		

Signal Descriptions – Ball Grid Array Packages

Signal Name	Function	Description
$\overline{\text{SSFLAG}}$	Digital Input	Subsystem Flag (RT) or External Trigger input. In RT mode, this signal functions as $\overline{\text{SSFLAG}}$. If asserted (logic "0"), the Subsystem Flag bit will be set in the transmitted RT Status Word. In BC or MT modes, this signal functions as an External Trigger as follows.
or	or	BC Mode
		Non-Enhanced Mode (Legacy) No function.
		Enhanced Mode (Legacy) If the external trigger is enabled by setting bit 7 in Configuration Register #1, a low-to-high transition on EXT_TRIG will initiate a BC Start.
EXT_TRIG	Digital Input	Enhanced Mode When a Wait for External Trigger (WTG) instruction is executed, the BC will wait for a low-to-high transition on EXT_TRIG before executing the next instruction.
		MT Mode
		Word Monitor If the external trigger is enabled by setting bit 7 in Configuration Register #1, a low-to-high transition on EXT_TRIG will start monitor operation.
		Message Monitor No effect.
$\overline{\text{TRANSPARENT}} / \overline{\text{BUFFERED}}$	Digital Input	Transparent or Buffered Mode Selection $\overline{\text{TRANSPARENT}} / \overline{\text{BUFFERED}} = "0"$ for Buffered Mode or $\overline{\text{TRANSPARENT}} / \overline{\text{BUFFERED}} = "1"$ for Transparent Mode
$\overline{\text{READYD}}$	Digital Output	This output indicates to the host processor the status or availability of data transferred to or from the device respectively. The host will initiate a transfer cycle by asserting $\overline{\text{STRBD}}$ low. When the data is ready the device will assert $\overline{\text{READYD}}$ low, indicating to the host that the transfer is complete. The host will then assert $\overline{\text{STRBD}}$ high, following which $\overline{\text{READYD}}$ will return to logic "1", indicating that the device is ready for the next transfer.
$\overline{\text{IOEN}}$	Digital Output	I/O Enable. This output allows tri-state control for external addresses and data buffers. It is asserted low during data transfer cycles and remains low until $\overline{\text{STRBD}}$ is asserted high ending the current transfer.

Signal Descriptions – Ball Grid Array Packages

Table 14. RT Address

Signal Name	Function	Description	
RTAD4 (MSB)	Digital Input	RT Address Input signals. NOTE: The RT address and parity may be programmed by software if bit 5 of Configuration Register #6 (RTADSRC) is set to logic "1". In this case, the RT Address and Parity are provided by the Host via data lines D5 – D0 and RTAD4:0 (and RTADP below) are not used.	
RTAD3	Digital Input		
RTAD2	Digital Input		
RTAD1	Digital Input		
RTAD0 (LSB)	Digital Input		
RTADP	Digital Input	Remote Terminal Address Parity. Used to provide odd parity for the RT address on RTAD[4:0].	
RT_AD_LAT	Digital Input	RT Address Latch. This input signal is used to control how the RT address is latched internally. If RT_AD_LAT is logic "0", then the RT address and parity will simply track RTAD4:0 and RTADP inputs. If RT_AD_LAT transitions from logic "0" to logic "1", the values on RTAD4:0 and RTADP will then be latched on the rising edge of RT_AD_LAT. If RT_AD_LAT is connected to logic "1", then the RT address is latched under software control, and depends on the value of bit 5 of Configuration Register #6 (RTADSRC) as follows:	
		RTADSRC bit 5 value	RT Address latch control when RT_AD_LAT = 1
		Logic "0" (Default)	The RT address and parity will be latched directly from the RTAD4:0 and RTADP input signals.
Logic "1"	RT address parity will be provided by the host by writing via the data bus inputs D5 – D1 for the address and D0 for parity. Note: Bit 3 of Configuration Register #4 (RTLATEN) must be written logic "1" while the RT address and parity are written via D5 – D0 to the lower 6 bits of Configuration Register #5 (RTAD[4:0] and RTADP (LSB)).		

Signal Descriptions – Ball Grid Array Packages

Table 15. Other Signals

Signal Name	Function	Description
UPADDREN	Digital Input	This input signal is used only for 4K device options to control the function of the 4 address inputs A15 – A12. See previous descriptions for A15 – A12. Note: For 64K devices, connecting this signal has no effect.
SLEEPIN	Digital Input	Connecting this input has no effect.
$\overline{\text{INCMD}}$	Digital Output	$\overline{\text{INCMD}}$ is asserted low whenever a message is in progress. In Word Monitor mode, $\overline{\text{INCMD}}$ remains low while the mode is active.
$\overline{\text{MCRST}}$	Digital Output	When in RT mode, this output will be asserted low for two clock cycles when a Reset Remote Terminal mode command is received.
RSTBITEN	Digital Input	If this input is set to logic "1", the Built-In-Self-Test feature will be enabled after a hardware reset. If this input is set to logic "0", automatic BIST is disabled.
$\overline{\text{INT}}$	Digital Output	Interrupt Request. If Configuration Register #2, bit 3 LEVEL is logic "0", the interrupt request output on $\overline{\text{INT}}$ will be a negative pulse of about 500 ns. If LEVEL is logic "1", the interrupt request output on $\overline{\text{INT}}$ will be a LOW continuous level. To clear the interrupt, one of following events should occur: 1. Logic "1" should be written to bit 2 of the Start/Reset Register (INTRST); or 2. If bit 4 of Configuration Register #2 (CLRSTAT) is logic "1", then reading the Interrupt Status Register will clear $\overline{\text{INT}}$. NOTE: In cases where both Interrupt Status Registers #1 and #2 have bits set, both registers must be read in order to clear $\overline{\text{INT}}$.
CLOCK_IN	Digital Input	20 MHz, 16 MHz, 12 MHz, or 10 MHz clock input.
TX_INH_A	Digital Input	Transmit inhibit inputs for Bus A and Bus B, active high. These two inputs enable (logic "0") or inhibit (logic "1") transmit on Bus A or Bus B, affecting behavior for all enabled 1553 devices.
TX_INH_B	Digital Input	
$\overline{\text{MSTCLR}}$	Digital Input	Master Reset, active low.
TAG_CLK	Digital Input	Time Tag Clock. This optional clock input may be used to increment the Time Tag Register. It is enabled by setting Bits 7, 8 and 9 of Configuration Register #2 (TTRES[9:7]) to [111].

Signal Descriptions – Ball Grid Array Packages

4.1. Operation in RT-only Mode with DMA Interface

The HI-62113PBx and HI-62115PBx 4K variants may be operated in an RT-only mode with Direct Memory Access (DMA) interface by simultaneously connecting three balls to ground. This option may be used to provide an RT-only interface to a system without a microprocessor.

Table 16 summarizes the required connections to operate the devices in this mode.

Table 16. Enabling RT-only Mode with DMA Interface

HI-62113PBx (+3.3V) Ball No.	HI-62115PBx (+5V) Ball No.	Description
B10, F7, F14	B10, C12, D18	Connect to Logic Ground to enable RT-only mode with DMA.

5. Pin Descriptions – Gull Wing Packages

Table 17. Power and Ground

Signal Name	Function	Description
+3.3V_XCVR	Power Supply	+3.3V DC power supply for bus transceiver.
+5.0V_XCVR	Power Supply	+5.0V DC power supply for bus transceiver.
+3.3V_LOGIC	Power Supply	+3.3V DC power supply for digital logic.
+ 5.0V_LOGIC	Power Supply	+5.0V DC power supply for digital logic.
GND	Power Supply	Power supply ground.

Table 18. MIL-STD-1553 Bus Interface

Signal Name	Function	Description
TX/RX-A	Analog I/O	Bi-directional Bus A interface to external MIL-STD-1553 isolation transformer. Observe positive / negative polarity.
$\overline{\text{TX/RX-A}}$	Analog I/O	
TX/RX-B	Analog I/O	Bi-directional Bus B interface to external MIL-STD-1553 isolation transformer. Observe positive / negative polarity.
$\overline{\text{TX/RX-B}}$	Analog I/O	

Pin Descriptions – Gull Wing Packages

Table 19. Host Address and Data Buses

Signal Name	Function	Description																					
D15 (MSB) – D0 (LSB)	Data inputs or Data outputs	Bi-directional data bus for host read/write operations on registers and RAM.																					
A15 (MSB) – A0 (LSB)	Digital inputs	For 64K RAM devices these signals function as the address bus for host read/write operations on registers and RAM.																					
A15 / CLK_SEL_1 and A14 / CLK_SEL_0	Digital Input	For 4K RAM devices, the function of these signals depends on the value of UPADDREN.																					
		<table border="1"> <tr> <td>If UPADDREN = Logic "1", these signals are address lines.</td> <td colspan="3">If UPADDREN = Logic "0", these signals function as CLK_SEL_1 and CLK_SEL_0 and set the clock frequency as follows:</td> </tr> <tr> <td></td> <td>CLK_SEL_1</td> <td>CLK_SEL_0</td> <td>Clock Frequency</td> </tr> <tr> <td rowspan="4">A15 – A14</td> <td>0</td> <td>0</td> <td>10 MHz</td> </tr> <tr> <td>0</td> <td>1</td> <td>20 MHz</td> </tr> <tr> <td>1</td> <td>0</td> <td>12 MHz</td> </tr> <tr> <td>1</td> <td>1</td> <td>16 MHz</td> </tr> </table>	If UPADDREN = Logic "1" , these signals are address lines.	If UPADDREN = Logic "0" , these signals function as CLK_SEL_1 and CLK_SEL_0 and set the clock frequency as follows:				CLK_SEL_1	CLK_SEL_0	Clock Frequency	A15 – A14	0	0	10 MHz	0	1	20 MHz	1	0	12 MHz	1	1	16 MHz
		If UPADDREN = Logic "1" , these signals are address lines.	If UPADDREN = Logic "0" , these signals function as CLK_SEL_1 and CLK_SEL_0 and set the clock frequency as follows:																				
			CLK_SEL_1	CLK_SEL_0	Clock Frequency																		
		A15 – A14	0	0	10 MHz																		
0	1		20 MHz																				
1	0		12 MHz																				
1	1		16 MHz																				
A13 / LOGIC "1"	Digital Input	For 4K RAM devices, the function of this signal depends on the value of UPADDREN. If UPADDREN = Logic "1" , this signal functions as address line A13. If UPADDREN = Logic "0" , this signal MUST be connected to +V_LOGIC.																					
A12 / $\overline{\text{RTBOOT}}$	Digital Input	For 4K RAM devices, the function of this signal depends on the value of UPADDREN. If UPADDREN = Logic "1" , this signal functions as address line A12. If UPADDREN = Logic "0" , this signal functions as $\overline{\text{RTBOOT}}$. as follows:																					
		<table border="1"> <tr> <td>$\overline{\text{RTBOOT}}$ = Logic "1"</td> <td>$\overline{\text{RTBOOT}}$ = Logic "0"</td> </tr> <tr> <td>For an RT-only device, the device will initialize in Idle mode. For a BC/RT/MT device, the device will initialize in BC mode.</td> <td>Enable MIL-STD-1760 operation (the RT will initialize with the busy bit set in the RT Status Word).</td> </tr> </table>	$\overline{\text{RTBOOT}}$ = Logic "1"	$\overline{\text{RTBOOT}}$ = Logic "0"	For an RT-only device, the device will initialize in Idle mode. For a BC/RT/MT device, the device will initialize in BC mode.	Enable MIL-STD-1760 operation (the RT will initialize with the busy bit set in the RT Status Word).																	
$\overline{\text{RTBOOT}}$ = Logic "1"	$\overline{\text{RTBOOT}}$ = Logic "0"																						
For an RT-only device, the device will initialize in Idle mode. For a BC/RT/MT device, the device will initialize in BC mode.	Enable MIL-STD-1760 operation (the RT will initialize with the busy bit set in the RT Status Word).																						
A11 – A0 (LSB)	Digital Input	Lower 12 bits of 16-bit bi-directional address bus.																					

Table 20. Host Interface

Signal Name	Function	Description
$\overline{\text{SELECT}}$	Digital Input	The Host sets this signal to logic "0" to select the device for a transfer to / from RAM (or registers).
$\overline{\text{STRBD}}$	Digital Input	This signal is used by the host with the $\overline{\text{SELECT}}$ signal to initiate data transfers to / from the device. $\overline{\text{STRBD}}$ must remain low during the data transfer cycle.
RD / $\overline{\text{WR}}$	Digital Input	Read/Write. RD/ $\overline{\text{WR}}$ specifies reading or writing between the host. The polarity depends on the state of the POL_SEL signal (see below).
ADDR_LAT or $\overline{\text{MEMOE}}$	Digital Input or Digital Output	When in buffered mode, this signal is an input and functions as ADDR_LAT. When ADDR_LAT transitions low, it latches the values on A15 – A0, $\overline{\text{SELECT}}$, MEM / $\overline{\text{REG}}$, and MSB / LSB. When ADDR_LAT is high, the values of these signals track the respective inputs. When in transparent mode, this signal is an output and functions as $\overline{\text{MEMOE}}$. It is used to enable external RAM reads and should be connected to the $\overline{\text{OE}}$ input signal on an external RAM.
$\overline{\text{ZEROWAIT}}$ or $\overline{\text{MEMWR}}$	Digital Input or Digital Output	When in buffered mode, this signal is an input and functions as $\overline{\text{ZEROWAIT}}$ as follows; $\overline{\text{ZEROWAIT}} = "0"$ specifies zero wait mode, $\overline{\text{ZEROWAIT}} = "1"$ specifies non-zero wait mode. When in transparent mode, this signal is an output and functions as $\overline{\text{MEMWR}}$. It is used in transparent mode for external RAM data transfers and should be connected to the $\overline{\text{WR}}$ input signal on the external RAM.
16 / $\overline{8}$ or $\overline{\text{DTREQ}}$	Digital Input or Digital Output	When in buffered mode, this signal is an input and functions as 16 / $\overline{8}$. It is used to specify 16 bit data mode (16 / $\overline{8} = "1"$) or 8-bit data mode (16 / $\overline{8} = "0"$). When in transparent mode, this signal is an output and functions as $\overline{\text{DTREQ}}$ (Data Transfer Request). It is used by the device to request access to the host address and data buses. The handshake is complete when the $\overline{\text{DTGRT}}$ (Data Transfer Grant) signal is asserted in response.
MSB / LSB or $\overline{\text{DTGRT}}$	Digital Input or Digital Input	When in buffered mode (8-bit only), this signal is an input and functions as (MSB / LSB). It is used to indicate whether the MSB or LSB is currently being transferred. The polarity of MSB / LSB is controlled by the POL_SEL input (see below). When in transparent mode, this signal is an input and functions as the $\overline{\text{DTGRT}}$ signal. It completes the handshake following a $\overline{\text{DTREQ}}$ request and is asserted to indicate that control of the host address and data buses have been released to the device.

Pin Descriptions – Gull Wing Packages

Signal Name	Function	Description
POL_SEL	Digital Input	Polarity Select or Data Transfer Bus Acknowledge. When in buffered mode, this signal is an input and functions as POL_SEL. In 16-bit mode, it controls the polarity of the RD / \overline{WR} signal and in 8-bit mode it controls the polarity of the MSB / LSB signal as follows:
		POL_SEL 16-bit buffered mode 8-bit-buffered mode
		1 Assert RD / \overline{WR} = 1 for RD. Assert RD / \overline{WR} = 0 for WR. Assert MSB / LSB = 1 for LSB. Assert MSB / LSB = 0 for MSB.
		0 Assert RD / \overline{WR} = 0 for RD. Assert RD / \overline{WR} = 1 for WR. Assert MSB / LSB = 0 for LSB. Assert MSB / LSB = 1 for MSB.
or	or	
\overline{DTACK}	Digital Output	When in transparent mode, this signal is an output and functions as \overline{DTACK} . It is asserted to acknowledge a data transfer grant (DTGRT) and indicates that the device has accepted control of the host address and data buses.
TRIG_SEL	Digital Input	In 8-bit buffered mode, this signal is an input and functions as TRIG-SEL. It is used to select the "endianness" (byte order) of 16-bit word transfers to or from the device as follows:
		TRIG_SEL 8-bit buffered mode 16-bit buffered mode
		1 MSB followed by LSB. No function. May be left unconnected.
		0 LSB followed by MSB. No function. May be left unconnected.
or	or	
$\overline{MEMENA_IN}$	Digital Input	When in transparent mode, this signal is an input and functions as $\overline{MEMENA_IN}$. It is used as a Chip Select input to the internal RAM. NOTE: If only internal RAM is used, $\overline{MEMENA_IN}$ should be connected directly to the output of a OR Gate which has \overline{DTACK} and \overline{IOEN} as inputs.
MEM/ \overline{REG}	Digital Input	This input is used by the host to notify the device of memory or register access. MEM / \overline{REG} = "1" for memory access or MEM / \overline{REG} = "0" for register access.

Pin Descriptions – Gull Wing Packages

Signal Name	Function	Description						
\overline{SSFLAG}	Digital Input	<p>Subsystem Flag (RT) or External Trigger input.</p> <p>In RT mode, this signal functions as \overline{SSFLAG}. If asserted (logic "0"), the Subsystem Flag bit will be set in the transmitted RT Status Word.</p> <p>In BC or MT modes, this signal functions as an External Trigger as follows.</p>						
or	or	BC Mode						
		<table border="1" style="width: 100%; border-collapse: collapse;"> <tr> <td style="width: 50%;">Non-Enhanced Mode (Legacy)</td> <td>No function.</td> </tr> <tr> <td>Enhanced Mode (Legacy)</td> <td>If the external trigger is enabled by setting bit 7 in Configuration Register #1, a low-to-high transition on EXT_TRIG will initiate a BC Start.</td> </tr> <tr> <td>Enhanced Mode</td> <td>When a Wait for External Trigger (WTG) instruction is executed, the BC will wait for a low-to-high transition on EXT_TRIG before executing the next instruction.</td> </tr> </table>	Non-Enhanced Mode (Legacy)	No function.	Enhanced Mode (Legacy)	If the external trigger is enabled by setting bit 7 in Configuration Register #1, a low-to-high transition on EXT_TRIG will initiate a BC Start.	Enhanced Mode	When a Wait for External Trigger (WTG) instruction is executed, the BC will wait for a low-to-high transition on EXT_TRIG before executing the next instruction.
Non-Enhanced Mode (Legacy)	No function.							
Enhanced Mode (Legacy)	If the external trigger is enabled by setting bit 7 in Configuration Register #1, a low-to-high transition on EXT_TRIG will initiate a BC Start.							
Enhanced Mode	When a Wait for External Trigger (WTG) instruction is executed, the BC will wait for a low-to-high transition on EXT_TRIG before executing the next instruction.							
EXT_TRIG	Digital Input							
		MT Mode						
		<table border="1" style="width: 100%; border-collapse: collapse;"> <tr> <td style="width: 50%;">Word Monitor</td> <td>If the external trigger is enabled by setting bit 7 in Configuration Register #1, a low-to-high transition on EXT_TRIG will start monitor operation.</td> </tr> <tr> <td>Message Monitor</td> <td>No effect.</td> </tr> </table>	Word Monitor	If the external trigger is enabled by setting bit 7 in Configuration Register #1, a low-to-high transition on EXT_TRIG will start monitor operation.	Message Monitor	No effect.		
Word Monitor	If the external trigger is enabled by setting bit 7 in Configuration Register #1, a low-to-high transition on EXT_TRIG will start monitor operation.							
Message Monitor	No effect.							
$\overline{TRANSPARENT} / \overline{BUFFERED}$	Digital Input	<p>Transparent or Buffered Mode Selection</p> <p>$\overline{TRANSPARENT} / \overline{BUFFERED} = "0"$ for Buffered Mode or</p> <p>$\overline{TRANSPARENT} / \overline{BUFFERED} = "1"$ for Transparent Mode</p>						
\overline{READYD}	Digital Output	<p>This output indicates to the host processor the status or availability of data transferred to or from the device respectively.</p> <p>The host will initiate a transfer cycle by asserting \overline{STRBD} low. When the data is ready the device will assert \overline{READYD} low, indicating to the host that the transfer is complete. The host will then assert \overline{STRBD} high, following which \overline{READYD} will return to logic "1", indicating that the device is ready for the next transfer.</p>						

Pin Descriptions – Gull Wing Packages

Signal Name	Function	Description
$\overline{\text{IOEN}}$	Digital Output	I/O Enable. This output allows tri-state control for external addresses and data buffers. It is asserted low during data transfer cycles and remains low until $\overline{\text{STRBD}}$ is asserted high ending the current transfer.

Table 21. RT Address

Signal Name	Function	Description	
RTAD4 (MSB)	Digital Input	RT Address Input signals. NOTE: The RT address and parity may be programmed by software if bit 5 of Configuration Register #6 (RTADSRC) is set to logic "1". In this case, the RT Address and Parity are provided by the Host via data lines D5 – D0 and RTAD4:0 (and RTADP below) are not used.	
RTAD3	Digital Input		
RTAD2	Digital Input		
RTAD1	Digital Input		
RTAD0 (LSB)	Digital Input		
RTADP	Digital Input	Remote Terminal Address Parity. Used to provide odd parity for the RT address on RTAD[4:0].	
RT_AD_LAT	Digital Input	RT Address Latch. This input signal is used to control how the RT address is latched internally. If RT_AD_LAT is logic "0", then the RT address and parity will simply track RTAD4:0 and RTADP inputs. If RT_AD_LAT transitions from logic "0" to logic "1", the values on RTAD4:0 and RTADP will then be latched on the rising edge of RT_AD_LAT. If RT_AD_LAT is connected to logic "1", then the RT address is latched under software control, and depends on the value of bit 5 of Configuration Register #6 (RTADSRC) as follows:	
		RTADSRC bit 5 value	RT Address latch control when RT_AD_LAT = 1
		Logic "0" (Default)	The RT address and parity will be latched directly from the RTAD4:0 and RTADP input signals.
	Logic "1"	RT address parity will be provided by the host by writing via the data bus inputs D5 – D1 for the address and D0 for parity. Note: Bit 3 of Configuration Register #4 (RTLATEN) must be written logic "1" while the RT address and parity are written via D5 – D0 to the lower 6 bits of Configuration Register #5 (RTAD[4:0] and RTADP (LSB)).	

Table 22. Miscellaneous Signals

Signal Name	Function	Description
UPADDREN	Digital Input	This input signal is used only for 4K device options to control the function of the 4 address inputs A15 – A12. See previous descriptions for A15 – A12. Note: For 64K devices, connecting this signal has no effect.
SLEEPIN	Digital Input	Connecting this input has no effect.
$\overline{\text{INCMD}}$ or	Digital Output	The function of this signal depends on the value of bit 0, Configuration Register #7 (MCRST). If MCRST is logic "0", this signal functions as the output $\overline{\text{INCMD}}$. $\overline{\text{INCMD}}$ is asserted low whenever a message is in progress. In Word Monitor mode, $\overline{\text{INCMD}}$ remains low while the mode is active.
$\overline{\text{MCRST}}$	Digital Output	If MCRST bit is logic "1", this signal functions as the output $\overline{\text{MCRST}}$. When in RT mode, this output will be asserted low for two clock cycles when a Reset Remote Terminal mode command is received.
$\overline{\text{INT}}$	Digital Output	Interrupt Request. If Configuration Register #2, bit 3 LEVEL is logic "0", the interrupt request output on $\overline{\text{INT}}$ will be a negative pulse of about 500 ns. If LEVEL is logic "1", the interrupt request output on $\overline{\text{INT}}$ will be a LOW continuous level. To clear the interrupt, one of following events should occur: <ol style="list-style-type: none"> 1. Logic "1" should be written to bit 2 of the Start/Reset Register (INTRST); or 2. If bit 4 of Configuration Register #2 (CLRSTAT) is logic "1", then reading the Interrupt Status Register will clear $\overline{\text{INT}}$. NOTE: In cases where both Interrupt Status Registers #1 and #2 have bits set, both registers must be read in order to clear $\overline{\text{INT}}$.
CLOCK_IN	Digital Input	20 MHz, 16 MHz, 12 MHz, or 10 MHz clock input.
TX_INH_A	Digital Input	Transmit inhibit inputs for Bus A and Bus B, active high. These two inputs enable (logic "0") or inhibit (logic "1") transmit on Bus A or Bus B, affecting behavior for all enabled 1553 devices.
TX_INH_B	Digital Input	
$\overline{\text{MSTCLR}}$	Digital Input	Master Reset, active low.
TAG_CLK	Digital Input	Time Tag Clock. This optional clock input may be used to increment the Time Tag Register. It is enabled by setting Bits 7, 8 and 9 of Configuration Register #2 (TTRES[9:7]) to [111].

Host Interface

6. Host Interface

The most commonly used host interface is the 16-bit buffered, non-zero wait mode. This configuration may be used to interface the device with a 16 or 32-bit microprocessor. In this mode the device does not access external memory and uses the internal 4K or 64K words of RAM for storing MIL-STD-1553 data and related buffering. Figure 4 and Table 23 illustrate host read timing and Figure 5 and Table 24 illustrate host write timing respectively.

6.1. Host RAM/Register Read (16-BIT Buffered, Nonzero Wait)

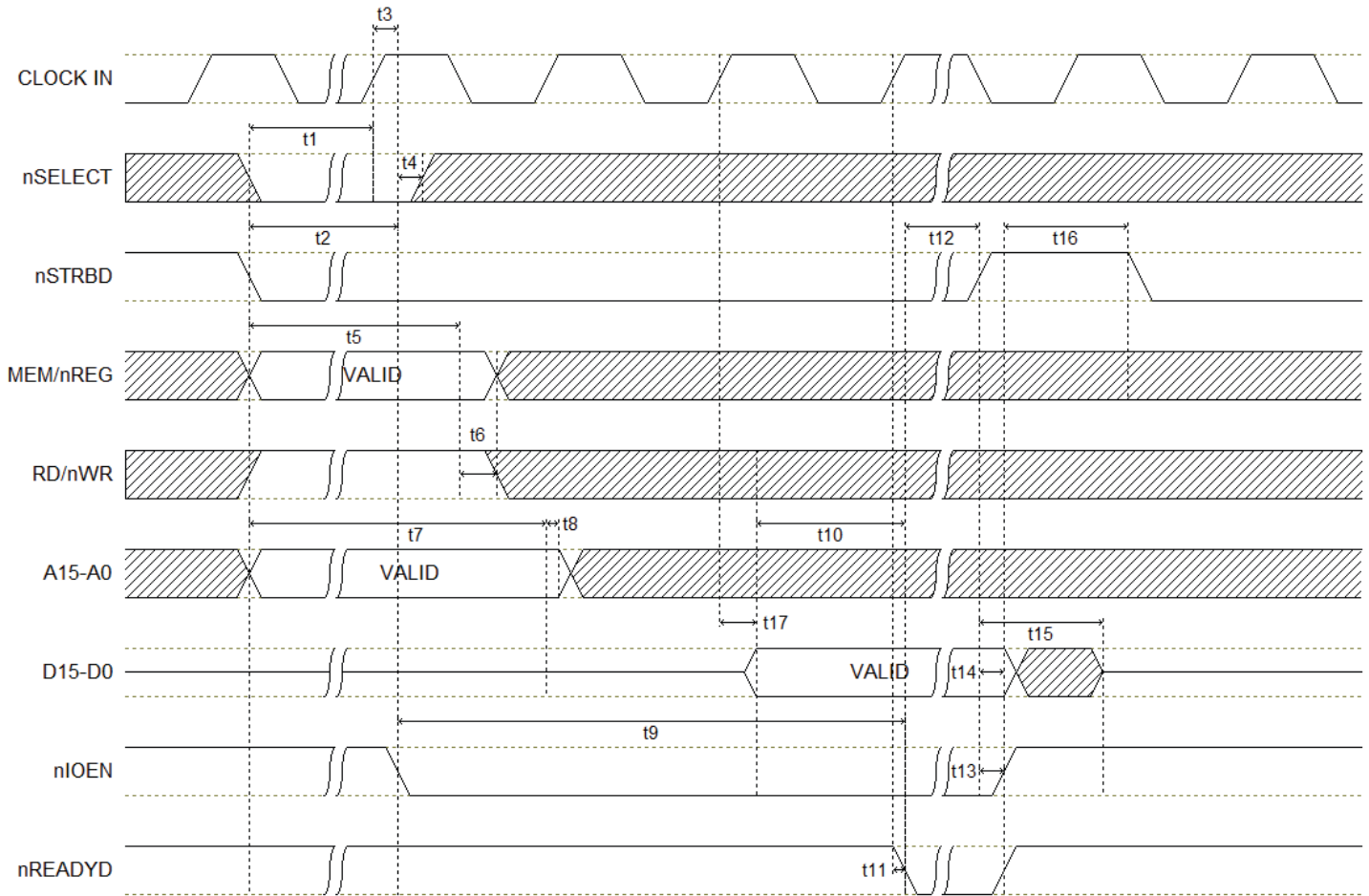

Note: Timing intervals not to scale. For illustration purposes only.

Figure 4. Host RAM/Register Read Timing Diagram (16-BIT Buffered, Nonzero Wait)

Table 23. Host RAM/Register Read Timing (16-BIT Buffered, Nonzero Wait)

Time	Description	Response Time						Units
		5V Logic			3.3V Logic			
		Min.	Typ.	Max.	Min.	Typ.	Max.	
t1	$\overline{\text{SELECT}}$ and $\overline{\text{STRBD}}$ low setup time to clock rising edge	10			15			ns
t2	$\overline{\text{SELECT}}$ and $\overline{\text{STRBD}}$ low to $\overline{\text{IOEN}}$ falling edge (No contention @ 20 MHz)			100			105	ns
	(Contention, with Bit 14, Config. Reg #6, ENHCPU = "0" @ 20 MHz)			3.6			3.6	μs
	(Contention, with ENHCPU = "1" @ 20 MHz)			515			520	ns
	(No contention @ 16 MHz)			112			117	ns
	(Contention, with ENHCPU = "0" @ 16 MHz)			4.6			4.6	μs
	(Contention, with ENHCPU = "1" @ 16 MHz)			630			635	ns
	(No contention @ 12 MHz)			133			138	ns
	(Contention, with ENHCPU = "0" @ 12 MHz)			6.0			6.0	μs
	(Contention, with ENHCPU = "1" @ 12 MHz)			815			820	ns
	(No contention @ 10 MHz)			150			155	ns
	(Contention, with ENHCPU = "0" @ 10 MHz)			7.2			7.2	μs
	(Contention, with ENHCPU = "1" @ 10 MHz)			965			970	ns
t3	$\overline{\text{IOEN}}$ falling edge delay from CLOCK IN rising edge.			40			40	ns
t4	$\overline{\text{SELECT}}$ hold time from $\overline{\text{IOEN}}$ falling edge	0			0			ns
t5	MEM / $\overline{\text{REG}}$ and RD / $\overline{\text{WR}}$ setup time to CLOCK IN falling edge	10			15			ns
t6	MEM / $\overline{\text{REG}}$ and RD / $\overline{\text{WR}}$ hold time from CLOCK IN falling edge	30			30			ns
t7	Address valid setup time to CLOCK IN rising edge	30			35			ns
t8	Address valid hold time from CLOCK IN rising edge	30			30			ns

Host Interface

Time	Description	Response Time						Units
		5V Logic			3.3V Logic			
		Min.	Typ.	Max.	Min.	Typ.	Max.	
t9	$\overline{\text{IOEN}}$ falling edge delay to $\overline{\text{READYD}}$ falling edge (@ 20 MHz)	135	150	165	135	150	165	ns
	(@ 16 MHz)	170	187.5	205	170	187.5	205	ns
	(@ 12 MHz)	235	250	265	235	250	265	ns
	(@ 10 MHz)	285	300	315	285	300	315	ns
t10	Output Data valid to $\overline{\text{READYD}}$ falling edge (@ 20 MHz)	21			11			ns
	(@ 16 MHz)	33			23			ns
	(@ 12 MHz)	54			44			ns
	(@ 10 MHz)	71			61			ns
t11	$\overline{\text{READYD}}$ falling edge delay from CLOCK IN rising edge.			40			40	ns
t12	$\overline{\text{READYD}}$ falling edge to $\overline{\text{STRBD}}$ rising edge			∞			∞	ns
t13	$\overline{\text{STRBD}}$ rising edge delay to $\overline{\text{IOEN}}$ and $\overline{\text{READYD}}$ rising edge			30			40	ns
t14	Output Data hold time from $\overline{\text{STRBD}}$ rising edge	0			0			ns
t15	$\overline{\text{STRBD}}$ rising edge delay to output data tri-state			40			40	ns
t16	$\overline{\text{STRBD}}$ high hold time from $\overline{\text{READYD}}$ rising edge	0			0			ns
t17	CLOCK IN rising edge delay to output data valid			40			40	ns

6.2. Host RAM/Register Write (16-BIT Buffered, Nonzero Wait)

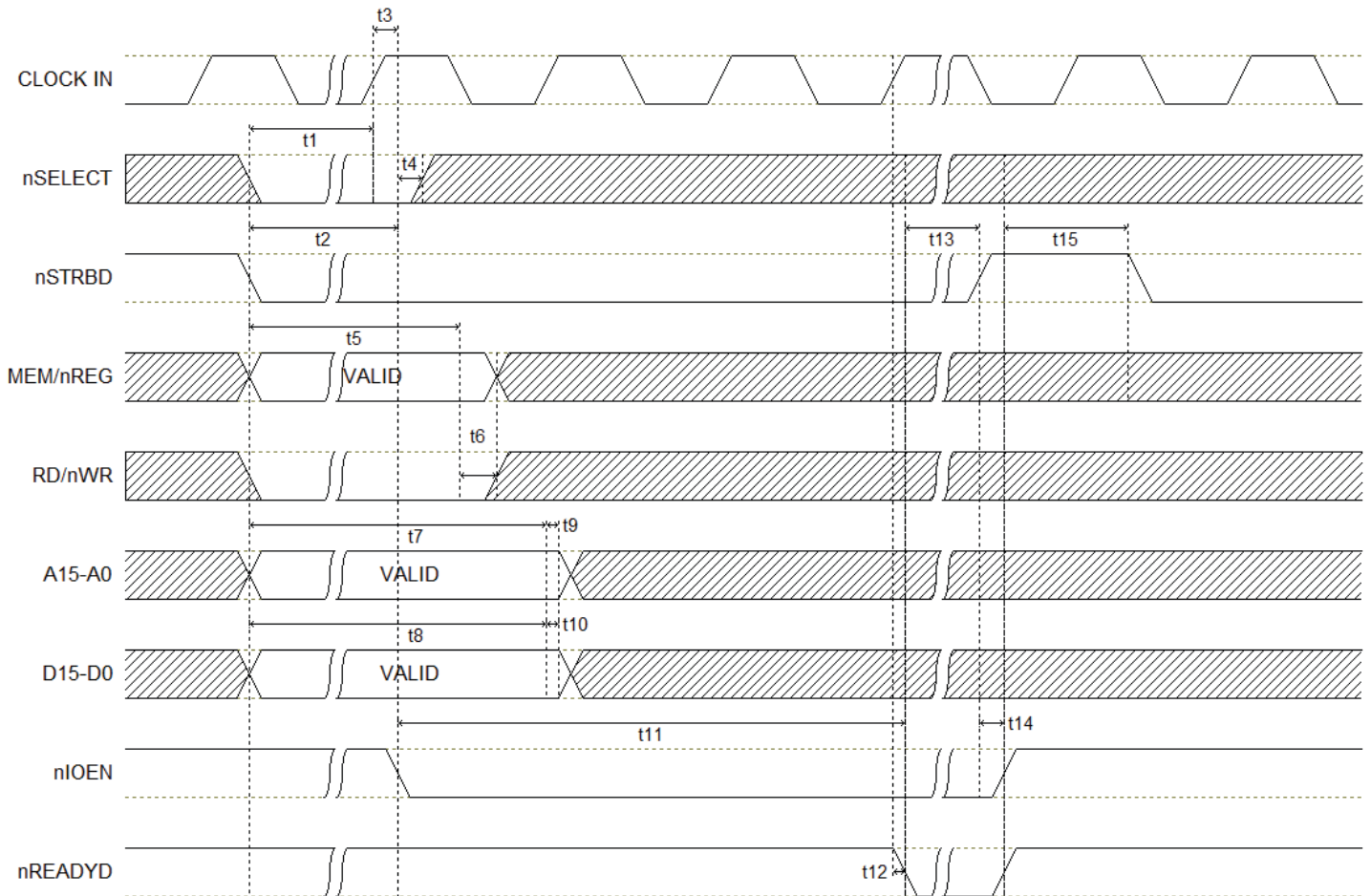

Note: Timing intervals not to scale. For illustration purposes only.

Figure 5. Host RAM/Register Write Timing Diagram (16-BIT Buffered, Nonzero Wait)

Host Interface

Table 24. Host RAM/Register Write Timing (16-BIT Buffered, Nonzero Wait)

Time	Description	Response Time						Units
		5V Logic			3.3V Logic			
		Min.	Typ.	Max.	Min.	Typ.	Max.	
t1	$\overline{\text{SELECT}}$ and $\overline{\text{STRBD}}$ low setup time to clock rising edge	10			15			ns
t2	$\overline{\text{SELECT}}$ and $\overline{\text{STRBD}}$ low to $\overline{\text{IOEN}}$ falling edge (No contention @ 20 MHz)			100			105	ns
	(Contention, with Bit 14, Config. Reg #6, ENHCPU = "0" @ 20 MHz)			3.6			3.6	μs
	(Contention, with ENHCPU = "1" @ 20 MHz)			465			470	ns
	(No contention @ 16 MHz)			112			117	ns
	(Contention, with ENHCPU = "0" @ 16 MHz)			4.6			4.6	μs
	(Contention, with ENHCPU = "1" @ 16 MHz)			565			570	ns
	(No contention @ 12 MHz)			133			138	ns
	(Contention, with ENHCPU = "0" @ 12 MHz)			6.0			6.0	μs
	(Contention, with ENHCPU = "1" @ 12 MHz)			732			737	ns
	(No contention @ 10 MHz)			150			155	ns
	(Contention, with ENHCPU = "0" @ 10 MHz)			7.2			7.2	μs
	(Contention, with ENHCPU = "1" @ 10 MHz)			865			870	ns
t3	$\overline{\text{IOEN}}$ falling edge delay from CLOCK IN rising edge.			40			40	ns
t4	$\overline{\text{SELECT}}$ hold time from $\overline{\text{IOEN}}$ falling edge	0			0			ns
t5	MEM / $\overline{\text{REG}}$ and RD / $\overline{\text{WR}}$ setup time to CLOCK IN falling edge	10			15			ns
t6	MEM / $\overline{\text{REG}}$ and RD / $\overline{\text{WR}}$ hold time from CLOCK IN falling edge	30			35			ns
t7	Address valid setup time to CLOCK IN rising edge	30			35			ns
t8	Data valid setup time to CLOCK IN rising edge	10			15			ns
t9	Address valid hold time from CLOCK IN rising edge	30			30			ns

Time	Description	Response Time						Units
		5V Logic			3.3V Logic			
		Min.	Typ.	Max.	Min.	Typ.	Max.	
t10	Data valid hold time from CLOCK IN rising edge	10			15			ns
t11	$\overline{\text{IOEN}}$ falling edge delay to $\overline{\text{READYD}}$ falling edge (@ 20 MHz)	85	100	115	85	100	115	ns
	(@ 16 MHz)	110	125	140	110	125	140	ns
	(@ 12 MHz)	152	167	182	152	167	182	ns
	(@ 10 MHz)	185	200	215	185	200	215	ns
t12	$\overline{\text{READYD}}$ falling edge delay from CLOCK IN rising edge.			40			40	ns
t13	$\overline{\text{READYD}}$ falling edge to $\overline{\text{STRBD}}$ rising edge			∞			∞	ns
t14	$\overline{\text{STRBD}}$ rising edge delay to $\overline{\text{IOEN}}$ and $\overline{\text{READYD}}$ rising edge			30			40	ns
t15	$\overline{\text{STRBD}}$ high hold time from $\overline{\text{READYD}}$ rising edge	10			10			ns

Host Interface

6.3. Host RAM/Register Read (Transparent Mode)

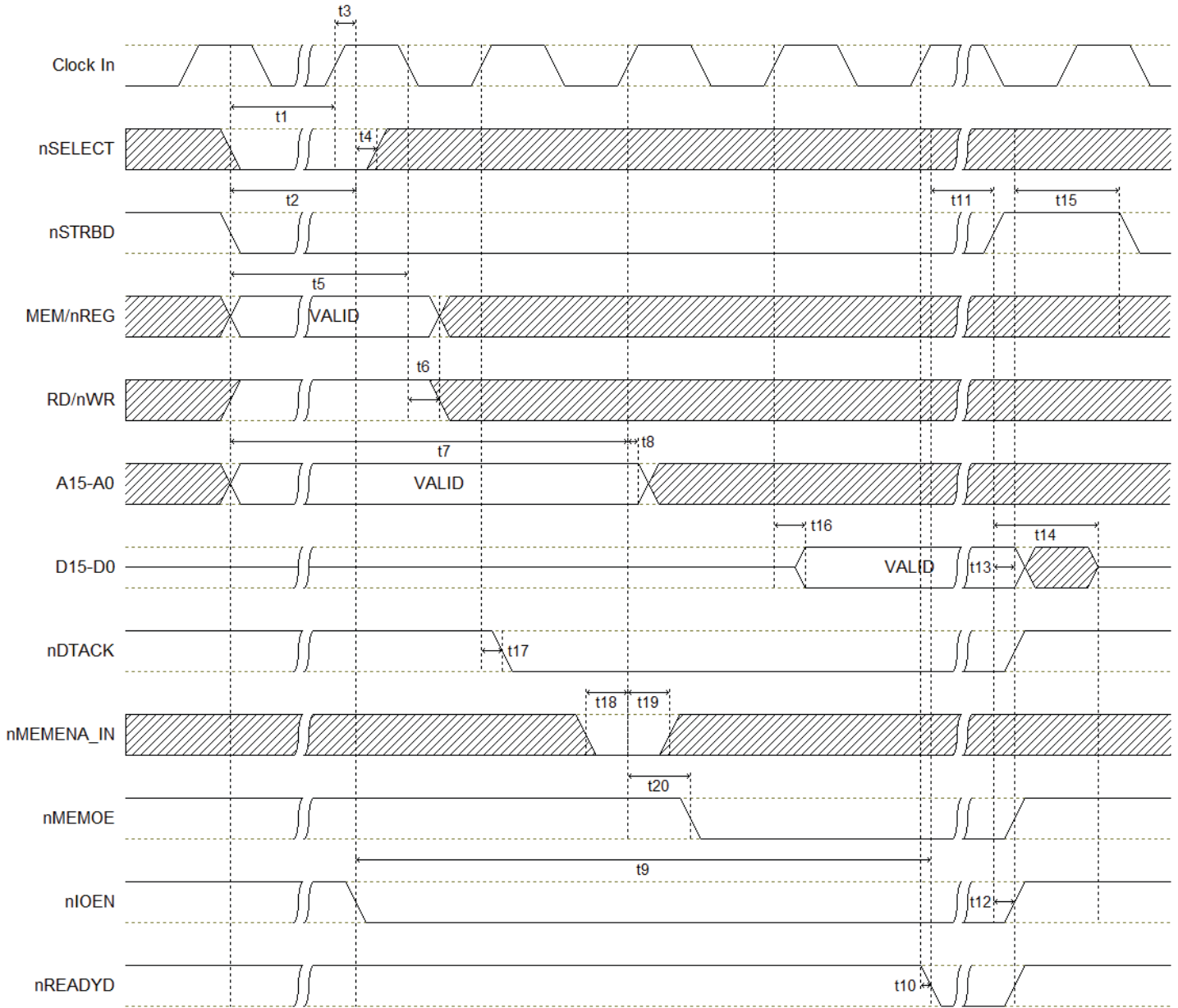

Note: Timing intervals not to scale. For illustration purposes only.

Figure 6. Host RAM/Register Read Timing Diagram (Transparent Mode)

Table 25. Host RAM/Register Read Timing (Transparent Mode)

Time	Description	Response Time						Units
		5V Logic			3.3V Logic			
		Min.	Typ.	Max.	Min.	Typ.	Max.	
t1	$\overline{\text{SELECT}}$ and $\overline{\text{STRBD}}$ low setup time to clock rising edge	10			15			ns
t2	$\overline{\text{SELECT}}$ and $\overline{\text{STRBD}}$ low to $\overline{\text{IOEN}}$ falling edge (No contention @ 20 MHz)			100			105	ns
	(Contention @ 20 MHz)			3.6			3.6	μs
	(No contention @ 16 MHz)			112			117	ns
	(Contention @ 16 MHz)			4.6			4.6	μs
	(No contention @ 12 MHz)			133			138	ns
	(Contention @ 12 MHz)			6.0			6.0	μs
	(No contention @ 10 MHz)			150			155	ns
	(Contention @ 10 MHz)			7.2			7.2	μs
t3	$\overline{\text{IOEN}}$ falling edge delay from CLOCK IN rising edge.			40			40	ns
t4	$\overline{\text{SELECT}}$ hold time from $\overline{\text{IOEN}}$ falling edge	0			0			ns
t5	MEM / $\overline{\text{REG}}$ and RD / $\overline{\text{WR}}$ setup time to CLOCK IN falling edge	10			15			ns
t6	MEM / $\overline{\text{REG}}$ and RD / $\overline{\text{WR}}$ hold time from CLOCK IN falling edge	30			30			ns
t7	Address valid setup time to CLOCK IN rising edge	30			35			ns
t8	Address valid hold time from CLOCK IN rising edge	30			30			ns
t9	$\overline{\text{IOEN}}$ falling edge delay to $\overline{\text{READYD}}$ falling edge (@ 20 MHz)	185	200	215	185	200	215	ns
	(@ 16 MHz)	235	250	265	235	250	265	ns
	(@ 12 MHz)	315	333	350	315	333	350	ns
	(@ 10 MHz)	385	400	415	385	400	415	ns
t10	$\overline{\text{READYD}}$ falling edge delay from CLOCK IN rising edge.			40			40	ns
t11	$\overline{\text{READYD}}$ falling edge to $\overline{\text{STRBD}}$ rising edge			5.0			5.0	μs
t12	$\overline{\text{STRBD}}$ rising edge delay to $\overline{\text{IOEN}}$ and $\overline{\text{READYD}}$ rising edge			30			40	ns

Host Interface

Time	Description	Response Time						Units
		5V Logic			3.3V Logic			
		Min.	Typ.	Max.	Min.	Typ.	Max.	
t13	Output Data hold time from $\overline{\text{STRBD}}$ rising edge	0			0			ns
t14	$\overline{\text{STRBD}}$ rising edge delay to output data tri-state			40			40	ns
t15	$\overline{\text{STRBD}}$ high hold time from $\overline{\text{READYD}}$ rising edge	0			0			ns
t16	CLOCK IN rising edge delay to output data valid			40			40	ns
t17	CLOCK IN rising edge delay to $\overline{\text{DTACK}}$ falling edge			40			40	ns
t18	$\overline{\text{MEMENA_IN}}$ setup time to CLOCK IN rising edge	10			10			ns
t19	$\overline{\text{MEMENA_IN}}$ hold time from CLOCK IN rising edge	30			30			ns
t20	CLOCK IN rising edge delay to $\overline{\text{MEMOE}}$ falling edge			40			40	ns

6.4. Host RAM/Register Write (Transparent Mode)

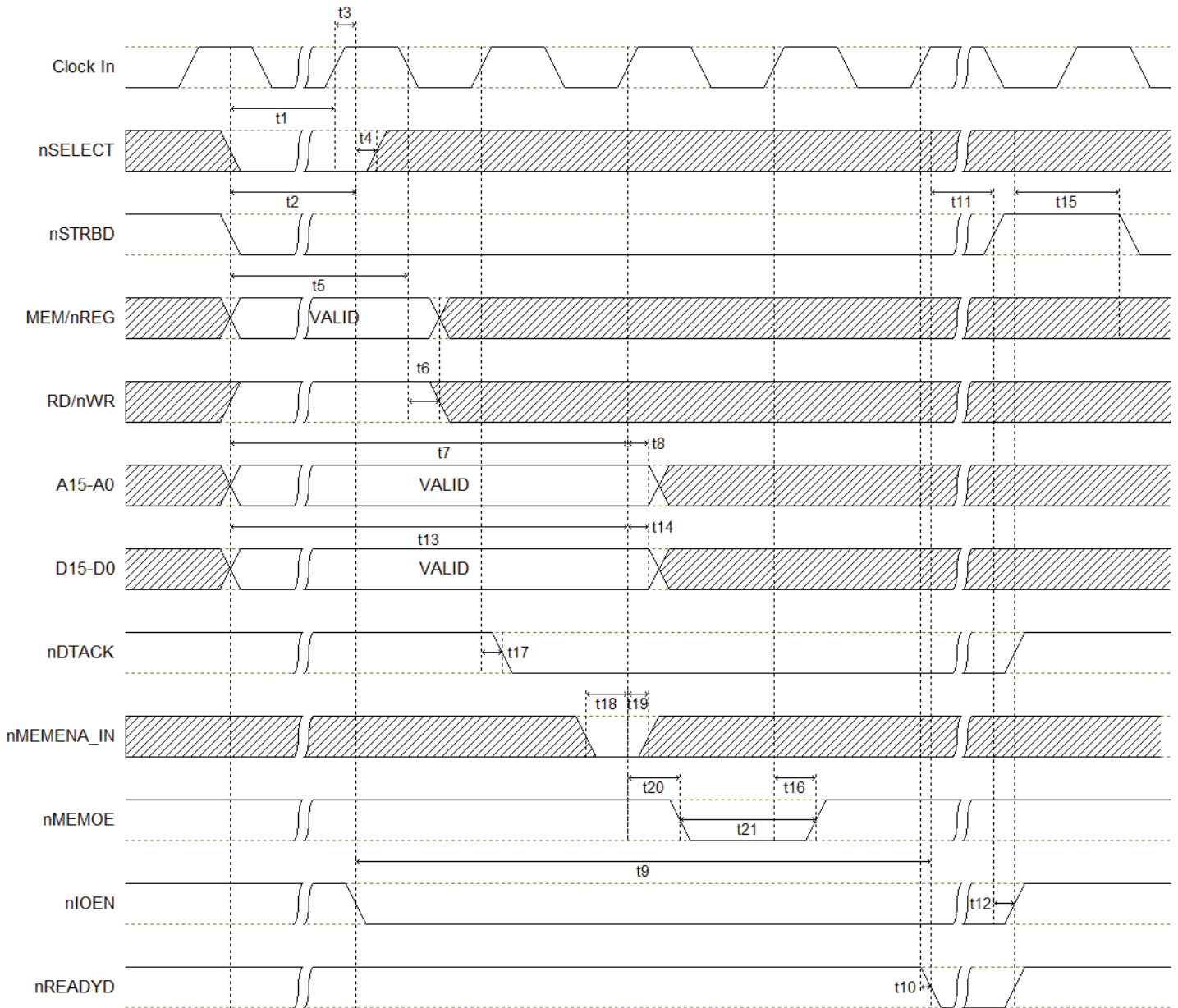

Note: Timing intervals not to scale. For illustration purposes only.

Figure 7. Host RAM/Register Write Timing Diagram (Transparent Mode)

Host Interface

Table 26. Host RAM/Register Write Timing (Transparent Mode)

Time	Description	Response Time						Units
		5V Logic			3.3V Logic			
		Min.	Typ.	Max.	Min.	Typ.	Max.	
t1	$\overline{\text{SELECT}}$ and $\overline{\text{STRBD}}$ low setup time to clock rising edge	10			15			ns
t2	$\overline{\text{SELECT}}$ and $\overline{\text{STRBD}}$ low to $\overline{\text{IOEN}}$ falling edge (No contention @ 20 MHz)			100			105	ns
	(Contention @ 20 MHz)			3.6			3.6	μs
	(No contention @ 16 MHz)			112			117	ns
	(Contention @ 16 MHz)			4.6			4.6	μs
	(No contention @ 12 MHz)			133			138	ns
	(Contention @ 12 MHz)			6.0			6.0	μs
	(No contention @ 10 MHz)			150			155	ns
	(Contention @ 10 MHz)			7.2			7.2	μs
t3	$\overline{\text{IOEN}}$ falling edge delay from CLOCK IN rising edge.			40			40	ns
t4	$\overline{\text{SELECT}}$ hold time from $\overline{\text{IOEN}}$ falling edge	0			0			ns
t5	MEM / $\overline{\text{REG}}$ and RD / $\overline{\text{WR}}$ setup time to CLOCK IN falling edge	10			15			ns
t6	MEM / $\overline{\text{REG}}$ and RD / $\overline{\text{WR}}$ hold time from CLOCK IN falling edge	30			30			ns
t7	Address valid setup time to CLOCK IN rising edge	30			10			ns
t8	Address valid hold time from CLOCK IN rising edge	30			25			ns
t9	$\overline{\text{IOEN}}$ falling edge delay to $\overline{\text{READYD}}$ falling (@ 20 MHz)	185	200	215	185	200	215	ns
	(@ 16 MHz)	235	250	265	235	250	265	ns
	(@ 12 MHz)	315	333	350	315	333	350	ns
	(@ 10 MHz)	385	400	415	385	400	415	ns
t10	$\overline{\text{READYD}}$ falling edge delay from CLOCK IN rising edge.			35			30	ns
t11	$\overline{\text{READYD}}$ edge falling to $\overline{\text{STRBD}}$ rising edge			5.0			5.0	μs
t12	$\overline{\text{STRBD}}$ rising edge delay to $\overline{\text{IOEN}}$ and $\overline{\text{READYD}}$ rising edge			30			35	ns

Time	Description	Response Time						Units
		5V Logic			3.3V Logic			
		Min.	Typ.	Max.	Min.	Typ.	Max.	
t13	Data setup time to CLOCK IN rising edge	10			10			ns
t14	Data hold time from CLOCK IN rising edge	30			25			ns
t15	$\overline{\text{STRBD}}$ high hold time from $\overline{\text{READYD}}$ rising edge	0			0			ns
t16	CLOCK IN rising edge delay to $\overline{\text{MEMOE}}$ rising edge			30			30	ns
t17	CLOCK IN rising edge delay to $\overline{\text{DTACK}}$ falling edge			35			30	ns
t18	$\overline{\text{MEMENA_IN}}$ setup time to CLOCK IN rising edge	5			10			ns
t19	$\overline{\text{MEMENA_IN}}$ hold time from CLOCK IN rising edge	30			25			ns
t20	CLOCK IN rising edge delay to $\overline{\text{MEMOE}}$ falling edge			40			30	ns
t21	$\overline{\text{MEMOE}}$ low pulse width (@ 20 MHz)	37		62	37		62	ns
	(@ 16 MHz)	50		75	50		75	ns
	(@ 12 MHz)	70		95	70		95	ns
	(@ 10 MHz)	87		112	87		112	ns

Electrical Characteristics

7. Electrical Characteristics

7.1. Absolute Maximum Ratings

Supply voltages	Logic	-0.3 V to +6.0 V
	Transceivers (not transmitting)	-0.3 V to +6.0 V
	Transceivers (transmitting)	-0.3 V to +4.5 V
Logic input voltage range		-0.3 V to +6.0 V
Receiver differential voltage		10 Vp-p
Solder Temperature (reflow)	HI-621xxPBxx	245°C
	HI-621xxCQxx and HI-621xxCFxx	260°C
Junction Temperature		175°C
Storage Temperature		-65°C to +150°C

7.2. Recommended Operating Conditions

Parameters		Limits			Unit
		Min	Typ	Max	
Supply Voltages	Logic	3.0	3.3	5.5	V
	3.3V Transceivers	3.14	3.3	3.46	V
	5.0V Transceivers	4.75	5.0	5.25	V
Temperature Range	Industrial	-40		85	°C
	Extended	-55		125	°C

7.3. DC Electrical Characteristics

T_A = Operating Temperature Range

Parameters	Symbol	Conditions	Limits			Unit	
			Min	Typ	Max		
Power Supply							
Operating Supply Voltages	Logic	V_{Logic}	3.0	3.3	5.5	V	
	3.3V Transceivers	V_{DD}	3.14	3.3	3.46	V	
	5.0V Transceivers	V_{DD}	4.5	5.0	5.5	V	
Power Supply Current HI-621x5PBx HI-62106PBx HI-621x5CQx See Note 1	$V_{Logic} = 3.3V$ $V_{DD} = 5.0V$	I_{CC1}	Not Transmitting	-	10	15	mA
		I_{CC2}	Continuous supply current while one bus transmits @ 50% duty cycle, 70Ω resistive load	-	295	330	mA
		I_{CC23}	Continuous supply current while one bus transmits @ 100% duty cycle, 70Ω resistive load	-	560	600	mA
Power Supply Current HI-621x3PBx HI-621x3CQx HI-621x4CQx See Note 1	$V_{Logic} = 3.3V = V_{DD}$	I_{CC1}	Not Transmitting	-	10	15	mA
		I_{CC2}	Continuous supply current while one bus transmits @ 50% duty cycle, 70Ω resistive load	-	335	410	mA
		I_{CC23}	Continuous supply current while one bus transmits @ 100% duty cycle, 70Ω resistive load	-	630	760	mA
Power Dissipation HI-621x5PBx HI-62106PBx HI-621x5CQx See Note 2	$V_{Logic} = 3.3V$ $V_{DD} = 5.0V$	PD_1	Not Transmitting	-	-	60	mW
		PD_2	Transmit one bus @ 50% duty cycle, 70Ω resistive load	-	1.0	1.1	W
		PD_3	Transmit one bus @ 100% duty cycle, 70Ω resistive load	-	1.45	1.55	W
Power Dissipation HI-621x3PBx HI-621x3CQx HI-621x4CQx See Note 3	$V_{Logic} = 3.3V = V_{DD}$	PD_1	Not Transmitting	-	-	60	mW
		PD_2	Transmit one bus @ 50% duty cycle, 70Ω resistive load	-	320	470	mW
		PD_3	Transmit one bus @ 100% duty cycle, 70Ω resistive load	-	450	620	mW
Logic							
Input Voltage (High)	V_{IH}	All digital inputs, except CLK_{IN}	2.1	-	-	V	
		CLK_{IN}	0.8			V_{DD}	
Input Voltage (Low)	V_{IL}	All digital inputs, except CLK_{IN}	-	-	0.7	V	
		CLK_{IN}			0.2	V_{DD}	

Electrical Characteristics

Parameters		Symbol	Conditions	Limits			Unit
				Min	Typ	Max	
Input Current (High)		I_{IH}	All digital inputs, except CLK _{IN} , $V_{LOGIC} = 3.6V = V_{IH}$	-10	-	-10	μA
			$V_{LOGIC} = 3.6V, V_{IH} = 2.7V$	-350	-	-33	μA
			$V_{LOGIC} = 5.25V = V_{IH}$	-10	-	-10	μA
			$V_{LOGIC} = 5.25V, V_{IH} = 2.7V$	-350	-	-50	μA
			CLK _{IN}	-10	-	10	μA
Input Current (Low)		I_{IL}	All digital inputs, except CLK _{IN} , $V_{LOGIC} = 3.6V, V_{IL} = 0.4V$	-350	-	-33	μA
			$V_{LOGIC} = 5.25V, V_{IL} = 0.4V$	-350	-	-50	μA
			CLK _{IN}	-10	-	10	μA
Output Voltage (High)		V_{OH}	$V_{LOGIC} = 3.0V, V_{IH} = 2.7V,$ $V_{IL} = 0.2V, I_{OH} = \text{max}$	2.4	-	-	V
			$V_{LOGIC} = 4.5V, V_{IH} = 2.7V,$ $V_{IL} = 0.2V, I_{OH} = \text{max}$	2.4	-	-	V
Output Voltage (Low)		V_{OL}	$V_{LOGIC} = 3.0V, V_{IH} = 2.7V,$ $V_{IL} = 0.2V, I_{OL} = \text{max}$	-	-	0.4	V
			$V_{LOGIC} = 4.5V, V_{IH} = 2.7V,$ $V_{IL} = 0.2V, I_{OL} = \text{max}$	-	-	0.4	V
Output Current (High)		I_{OH}	$V_{LOGIC} = 3.0V$	-	-	-2.2	mA
			$V_{LOGIC} = 4.5V$	-	-	-3.4	mA
Output Current (Low)		I_{OL}	$V_{LOGIC} = 3.0V$	2.2	-	-	mA
			$V_{LOGIC} = 4.5V$	3.4	-	-	mA
RECEIVER (Measured at Point "AD" in Figure 10 unless otherwise specified)							
Differential Input Resistance		R_{IN}	$V_{DD} = 3.3V$	2.4	-	-	k Ω
			$V_{DD} = 5.0V$	2.0	-	-	k Ω
Differential Input Capacitance		C_{IN}	Measured between pins TX/RX-A(B) and TX/RX-A(B). $V_{DD} = 5.0V$ or $3.3V$	-	-	35	pF
Common Mode Rejection Ratio		CMRR		40	-	-	dB
Input Level		V_{IN}	Differential	-	-	9	Vp-p
Input Common Mode Voltage		V_{ICM}		-10	-	+10	V-pk
Threshold Voltage (Direct-Coupled)	Detect	V_{THD}	1 MHz Sine Wave (Measured at Point "AD" in Figure 10)	1.2	-	20.0	Vp-p
	No Detect	V_{THND}		-	-	0.28	Vp-p
Threshold Voltage (Transformer-Coupled)	Detect	V_{THD}	1 MHz Sine Wave (Measured at Point "AT" in Figure 11)	0.86	-	14.0	Vp-p
	No Detect	V_{THND}		-	-	0.2	Vp-p

Electrical Characteristics

Parameters		Symbol	Conditions	Limits			Unit
				Min	Typ	Max	
TRANSMITTER (Measured at Point "AD" in Figure 10 unless otherwise specified)							
Output Voltage	Direct Coupled	V_{OUT}	35 Ω Load	6.0	7.0	9.0	Vp-p
	Transformer Coupled	V_{OUT}	70 Ω Load (Measured at Point "AT" in Figure 11)	20.0	21.5	27.0	Vp-p
Output Noise		V_{ON}	Differential, Direct Coupled	-	-	14.0	mVp-p
Output Dynamic Offset Voltage	Direct Coupled	V_{DYN}	35 Ω Load	-90	-	90	mV
	Transformer Coupled	V_{DYN}	70 Ω Load (Measured at Point "AT" in Figure 11)	-250	-	250	mVp
Rise/Fall Time	HI-621x3xxx HI-621x5xxx	$t_{r/f}$	MIL-STD-1553B compliant	100	150	300	ns
	HI-62106PBx HI-621x4CQx	$t_{r/f}$	McAir compliant	200	250	300	ns
Output Resistance		R_{OUT}	Differential, not transmitting	10	-	-	k Ω
Output Capacitance		C_{OUT}	1 MHz sine wave	-	-	15	pF
Clock Input							
Frequency	(Default)	CLK_{IN}			16.0		MHz
	(option)				12.0		MHz
	(option)				10.0		MHz
	(option)				20.0		MHz
Master Reset (MSTCLR) Timing							
Minimum MSTCLR pulsewidth for Master Reset		t_{MR}	Rise Time < 10 μ s	100			ns
MIL-STD-1553 Message Timing							
Completion of CPU write (BC Start) to Start of First Message for non-Enhanced BC Mode					2.5		μ s
BC intermessage gap time (typical value; may be lengthened under software control to 65.535 ms)		non-Enhanced BC Mode			9.5		μ s
		Enhanced BC Mode			10.5		μ s
BC/RT/MT Response Timeout (Software programmable, 4 options)		18.5 nominal		17.5	18.0	19.5	μ s
		22.5 nominal		21.5	22.5	23.5	μ s
		50.5 nominal		49.5	50.5	51.5	μ s
		128.0 nominal		127.0	129.5	131.0	μ s
RT Response Time (mid-parity to mid-sync)				4		7	μ s
Transmitter Watchdog Timeout					660.5		μ s

Note 1: In actual use, the highest practical transmit duty cycle is 96%, occurring when a Remote Terminal responds to a series of 32 data word transmit commands (RT to BC) repeating with minimum intermessage gap of 4 μ s (2 μ s dead time) and typical RT response delay of 5 μ s.

Note 2: While one bus continuously transmits, the power delivered by the 5.0V power supply is 5.0V \times 560mA typical = 2.8W. Of this, 1.45W is dissipated in the device, the remainder in the load.

Note 3: While one bus continuously transmits, the power delivered by the 3.3V power supply is 3.3V \times 630mA typical = 2.1W. Of this, 450mW is dissipated in the device, the remainder in the load.

Electrical Characteristics

7.4. MIL-STD-1553 Bus Interface

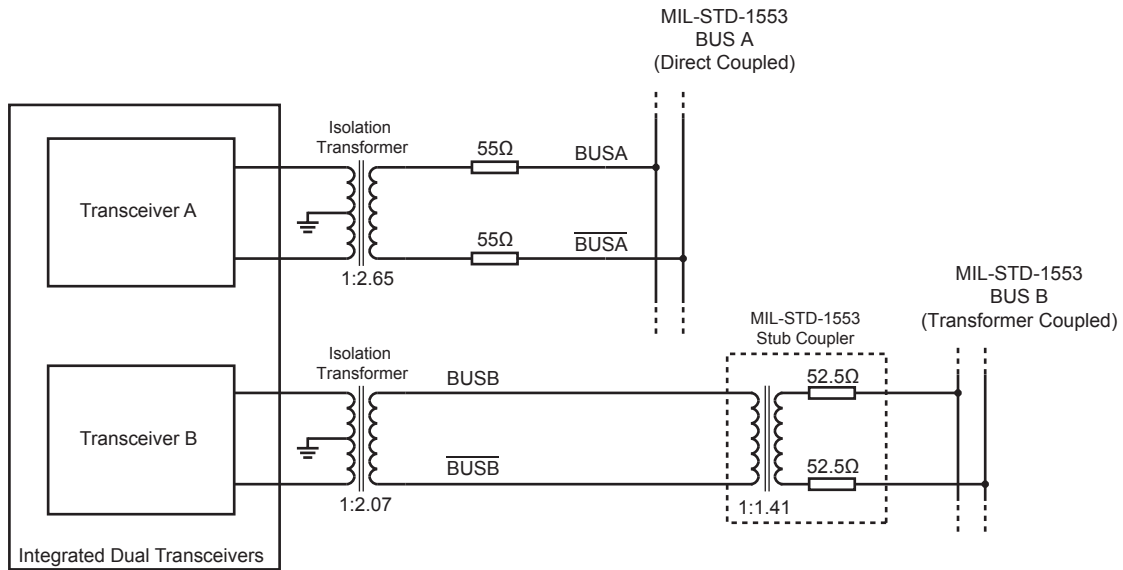

Figure 8. Bus Connection Example – 3.3V Transceivers

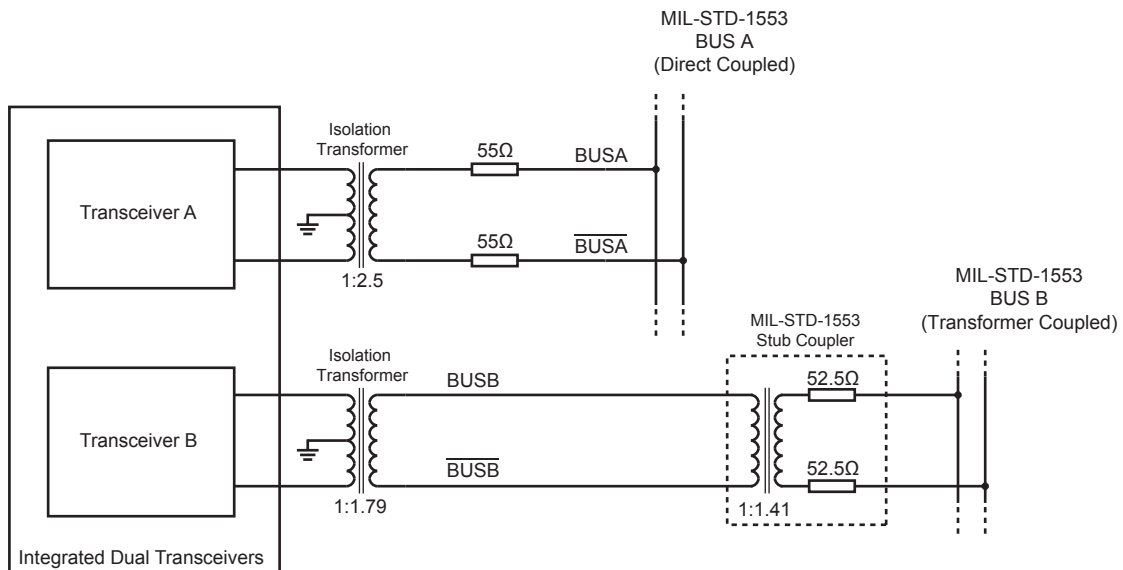

Figure 9. Bus Connection Example – 5.0V Transceivers

7.5. MIL-STD-1553 Test Circuits

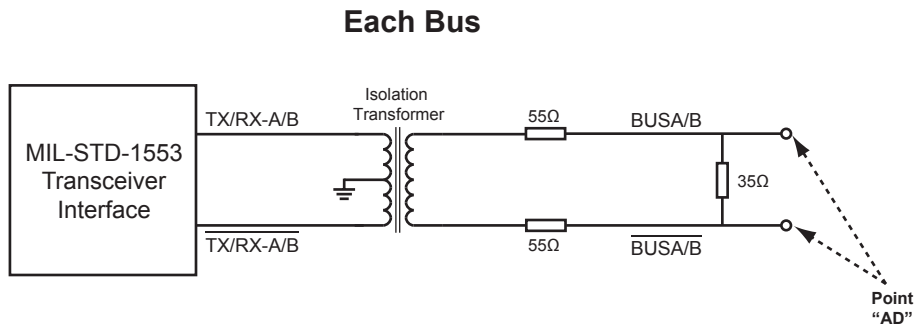

Figure 10. MIL-STD-1553 Direct Coupled Test Circuits

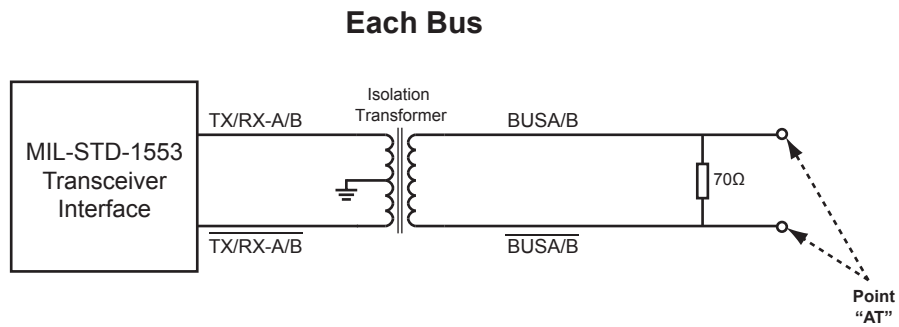

Figure 11. MIL-STD-1553 Transformer Coupled Test Circuits

Package Dimensions

8. Package Dimensions

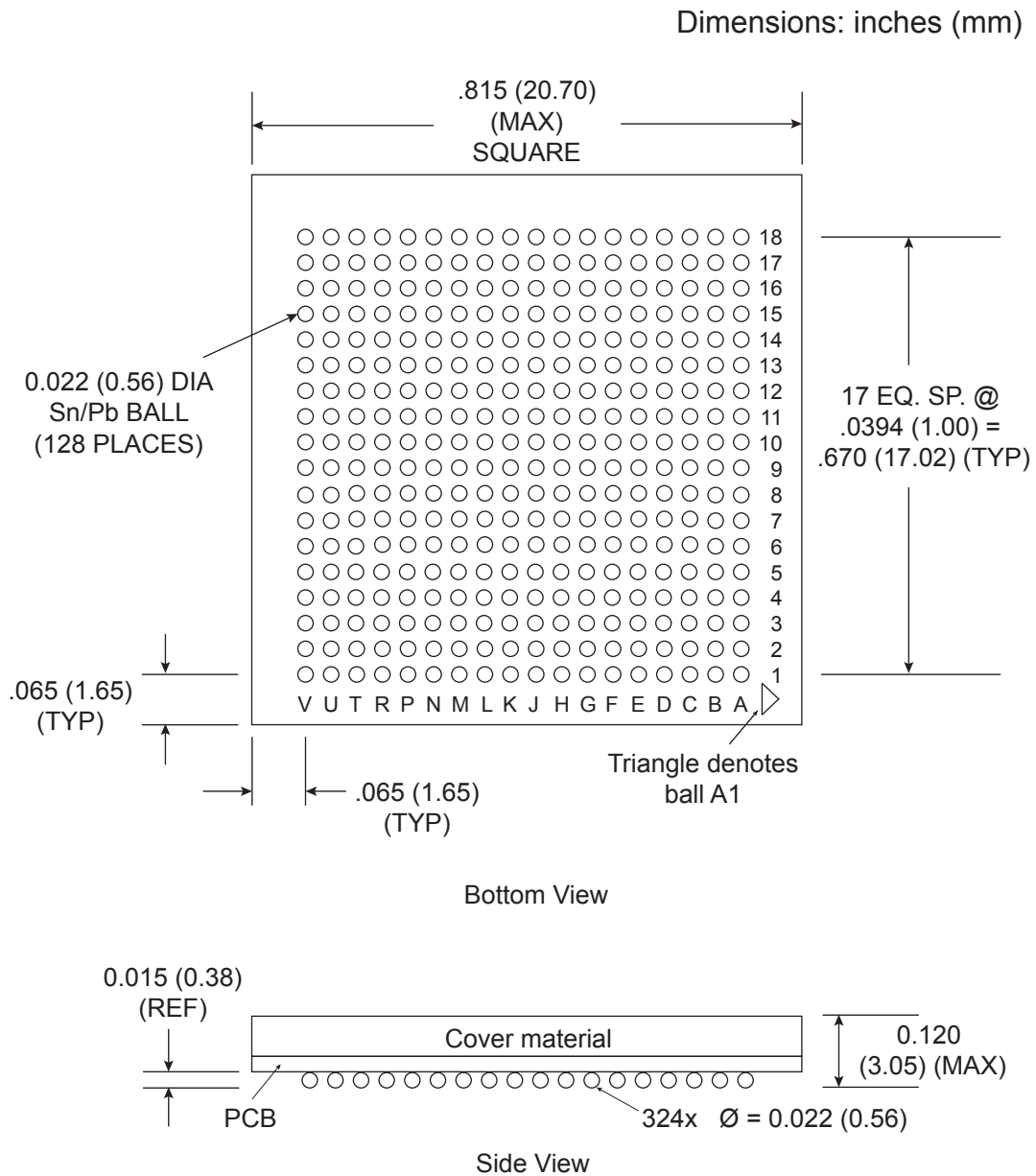

Figure 12. Ball Grid Array Package Dimensions (BGA-324)

Dimensions: inches (mm)

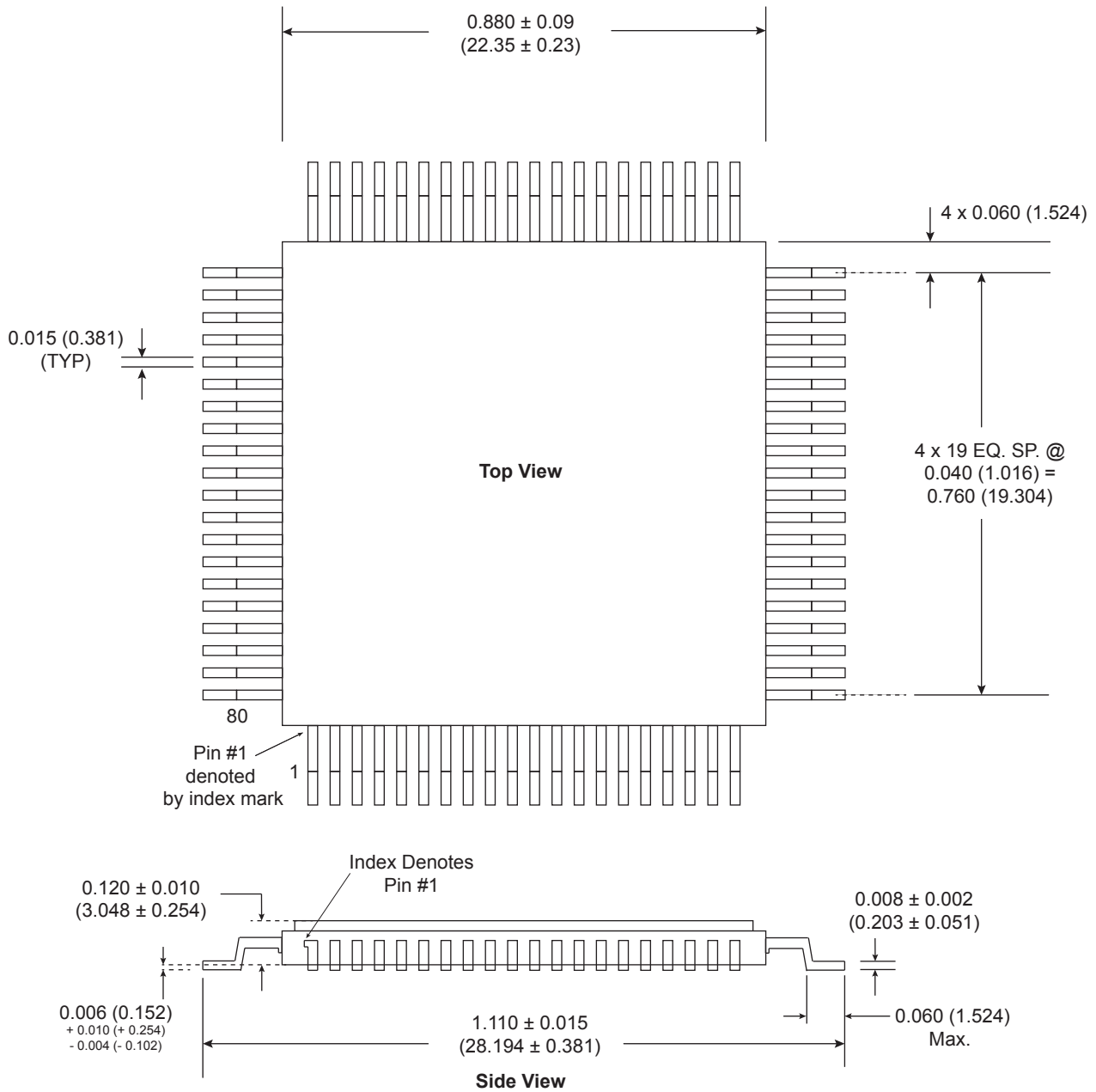

Figure 13. 80-Pin Gull Wing Package Dimensions

Package Dimensions

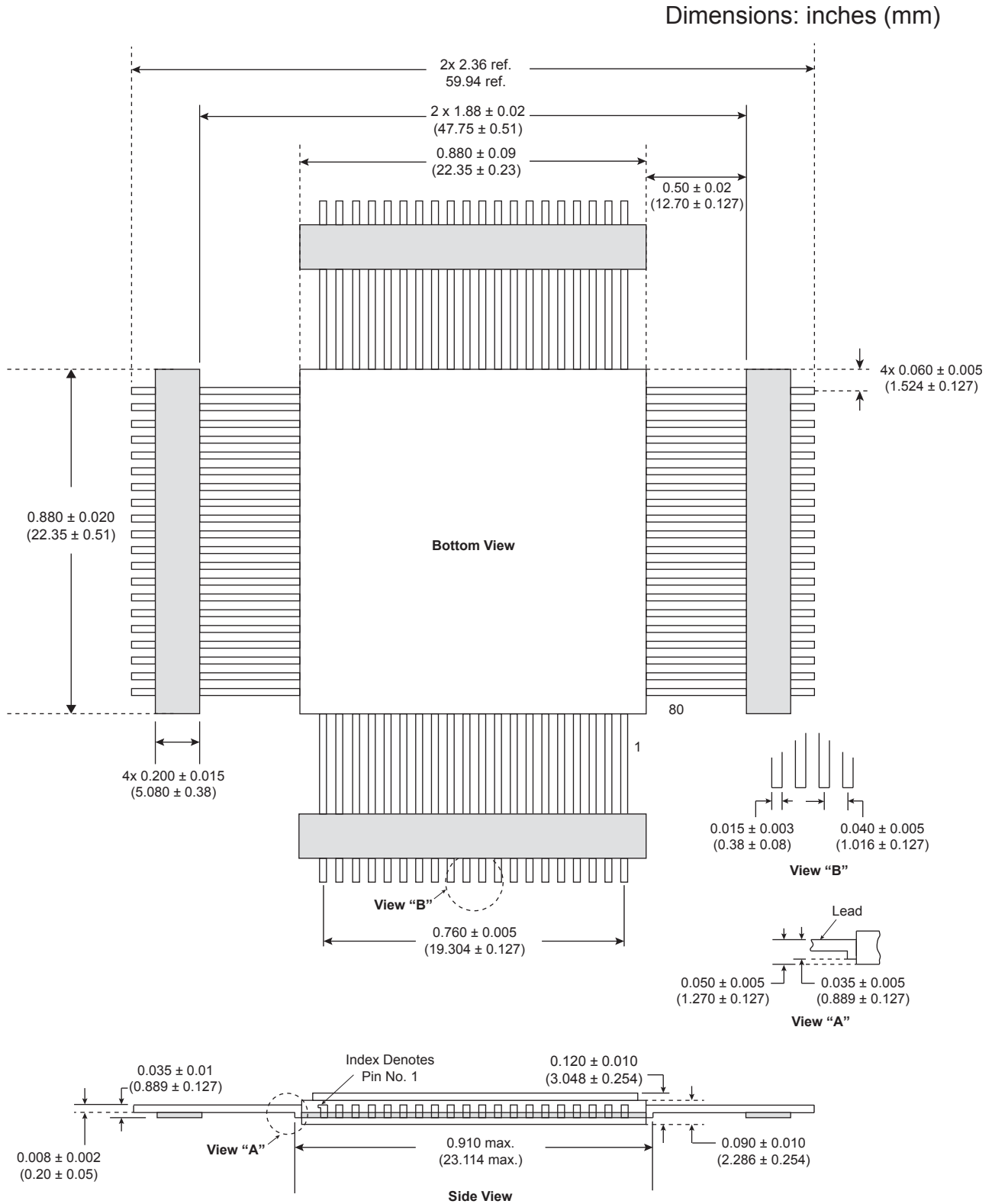
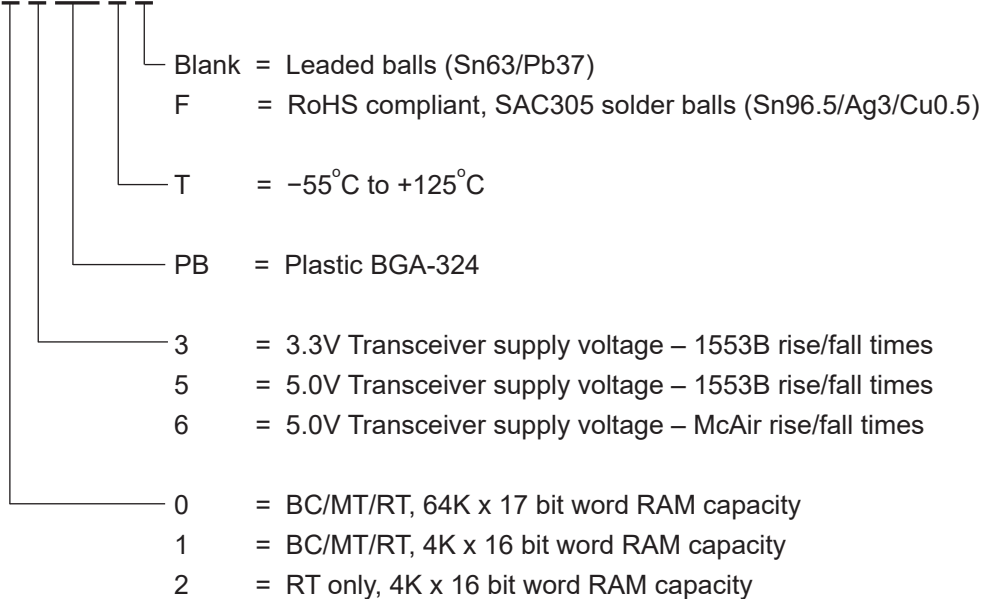

Figure 14. 80-Pin Flat Pack Package Dimensions

9. Ordering Information – 324 Ball BGA Package

HI - 621 x x PB x x



Ordering Information – 80 Pin Gull Wing Package

10. Ordering Information – 80 Pin Gull Wing Package

HI - 621 x x Cx x x

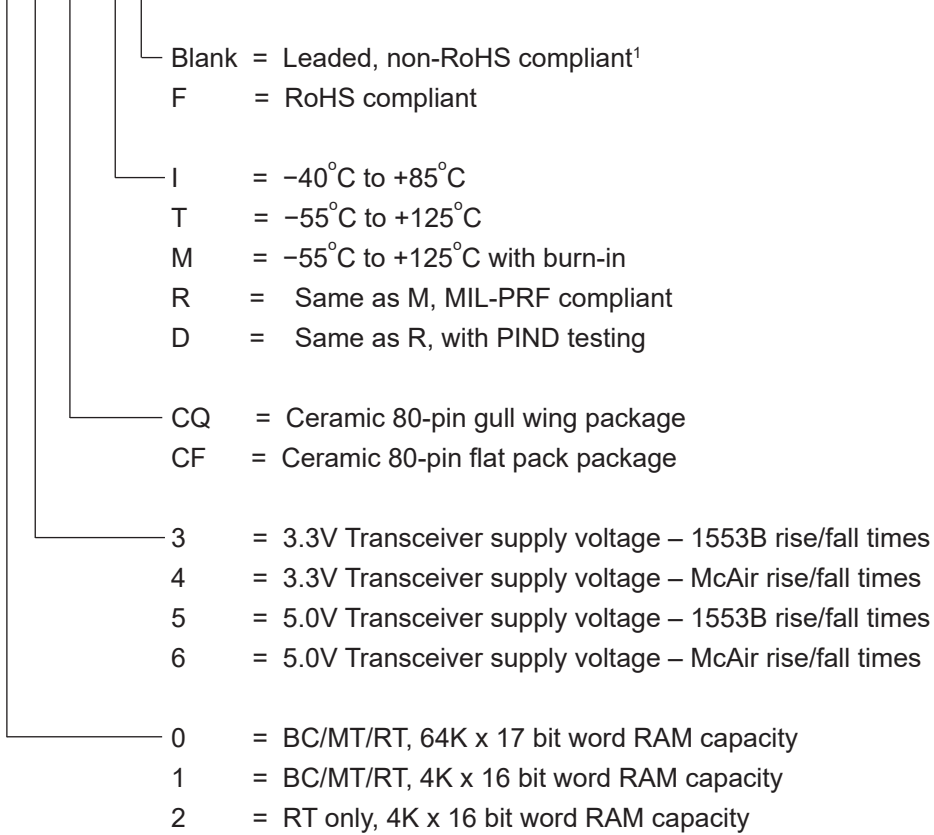

Note 1: Solder dipped, Sn/Pb solder

11. Revision History

Revision	Date	Description of Change
DS6210, Rev. New	05/23/18	Initial Release
A	07/02/18	Add BGA ball metallurgy to Ordering Information
B	05/20/19	Add package photos to title page. Add minor clarification to \overline{RTBOOT} signal description (enables MIL-STD-1760 operation). Add dimension units to package drawings.
C	08/01/19	Update parameters in Electrical Characteristics to align with electrical measurements. Update Reflow Temperature.
D	11/08/19	Add more detail to register definitions and block diagram. Add pin diagrams, clarify pin descriptions, update host interface timing diagrams. Add flat pack package option. Other minor updates and corrections.
E	12/17/19	Add Transparent Mode read and write timing diagrams. Update Buffered Mode read and write timing diagrams. READYD falling edge and related timings shown one clock period earlier. Parameter table values remain unchanged.
F	08/12/2020	Add part HI-62106Cxxx to Ordering Information (5.0V Transceiver supply voltage – McAir rise/fall times)
G	11/10/2020	Add note regarding +5.0V_RAM signal. Remove I-Grade BGA part from Ordering Information.
H	07/13/2021	Correct typo in description of RAMST, bit 9, register 0x0003. Clarify description of BIST, bit 1, register 0x001E. Correct solder reflow temperature in Absolute Maximum Ratings table for different package types. Add timing parameters for MSTCLR to Electrical Characteristics.
J	12/03/2021	Correct errors in description of buffering modes in “RT Subaddress Control Word Register 0x0004”. Add verbiage to describe how to configure HI-62113PBx and HI-62115PBx device variants in RT-only mode with DMA interface.
K	07/07/2022	Clarify power signal names on block diagram.