

Standard Products

**ACT4453 Single Supply Dual Transceiver**  
for MIL-STD-1553 A/B, MIL-STD-1760 & SAE-AS15531

[www.aeroflex.com/Avionics](http://www.aeroflex.com/Avionics)

June 29, 2015



**FEATURES**

- ❑ Single +5V power supply
- ❑ Outstanding MIL-STD-1553 / SAE-AS15531 performance
- ❑ Monolithic construction
- ❑ Input and output TTL compatible design
- ❑ Designed for commercial, industrial and aerospace applications
- ❑ MIL-PRF-38534 compliant devices available
- ❑ Aeroflex-Plainview is a Class H & K MIL-PRF-38534 manufacturer
- ❑ 1.9"L x .78"W, 36 lead, Dual-in-line or Flat package, hermetic package
- ❑ Available on DLA SMD 5962-89522

**GENERAL DESCRIPTION**

The radiation tolerant ACT4453 is the next generation monolithic transceiver design which provides full compliance with MIL-STD-1553A/B, MIL-STD-1760 and meets SAE-AS15531 requirements in the smallest packages with low power consumption and single power supply operation. The series performs the front-end analog function of inputting and outputting data through a transformer to the MIL-STD-1553 data bus.

Design of these transceivers reflects particular attention to active filter performance. This results in low bit and word error rate with superior waveform purity and minimal zero crossover distortion. Efficient transmitter electrical and thermal design provides low internal power dissipation and heat rise at high as well as low duty cycles.

Each channel of the dual transceiver is completely separate from the other and fully independent. This includes power leads as well as signal lines. Hence, each channel may be connected to a different data bus with no interaction.

**TRANSMITTER**

The Transmitter section accepts bi-phase TTL data at the input and when coupled to the data bus with a 1:2.12 ratio transformer the data bus signal is typically 7.0 Volts P-P at A-A' (See Figure 5). When both DATA and  $\overline{\text{DATA}}$  inputs are held low or high, the transmitter output becomes a high impedance and is "removed" from the line. In addition, an overriding "INHIBIT" input provides for the removal of the transmitter output from the line. A logic "1" applied to the "INHIBIT" takes priority over the condition of the data inputs and disables the transmitter (See Figure 1 Transmitter Logic Waveform). The Transmitter may be safely operated for an indefinite period with the bus (point A-A') short circuited at 100% duty cycle.

**RECEIVER**

The Receiver section accepts bi-phase differential data at the input and produces two TTL signals at the output. The outputs are DATA and  $\overline{\text{DATA}}$ , and represent positive and negative excursions of the input beyond a pre-determined threshold (See Figure 2 Receiver Logic Waveform).

The pre-set internal thresholds will detect data bus signals exceeding 1.20 Volts P-P and reject signals less than 0.6 Volts P-P when used with a transformer (See Figure 5 for transformer data and typical connections).

A low level at the Strobe input inhibits the DATA and  $\overline{\text{DATA}}$  outputs (Pin is internally pulled up).

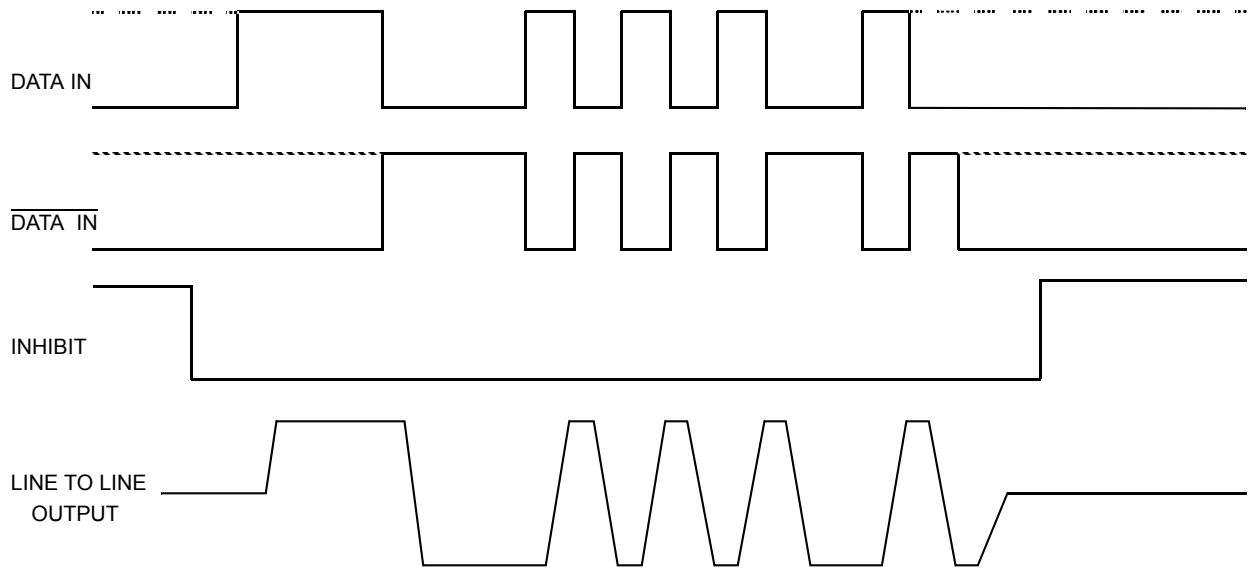
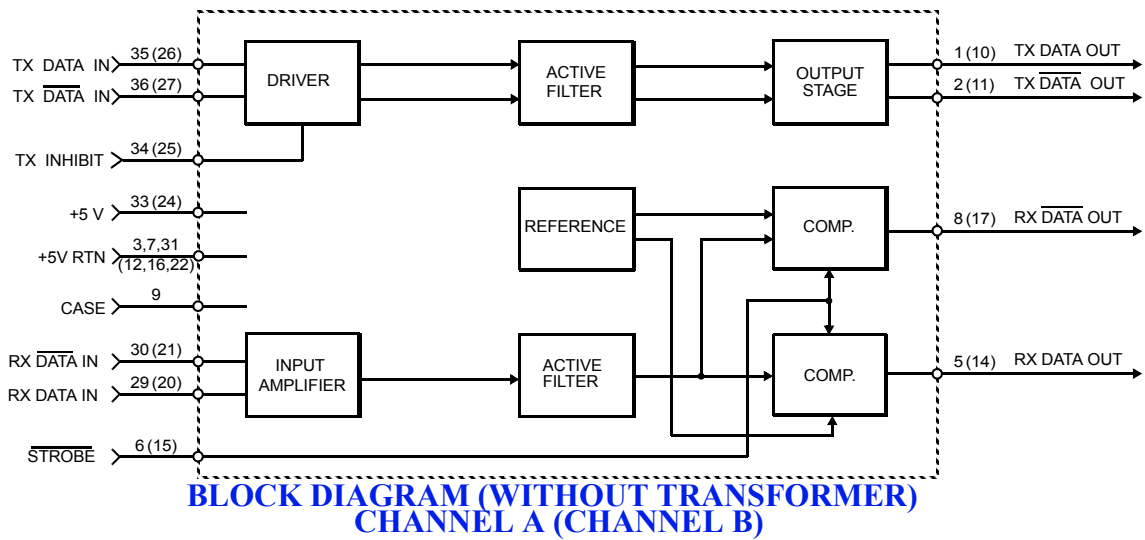

**Note:** DATA and  $\overline{\text{DATA}}$  inputs must be complementary waveforms or 50% duty cycle average, with no delays between them, and must be in the same state during off times (both high or low).

**FIGURE 1 – TRANSMITTER LOGIC WAVEFORMS IDEALIZED \***

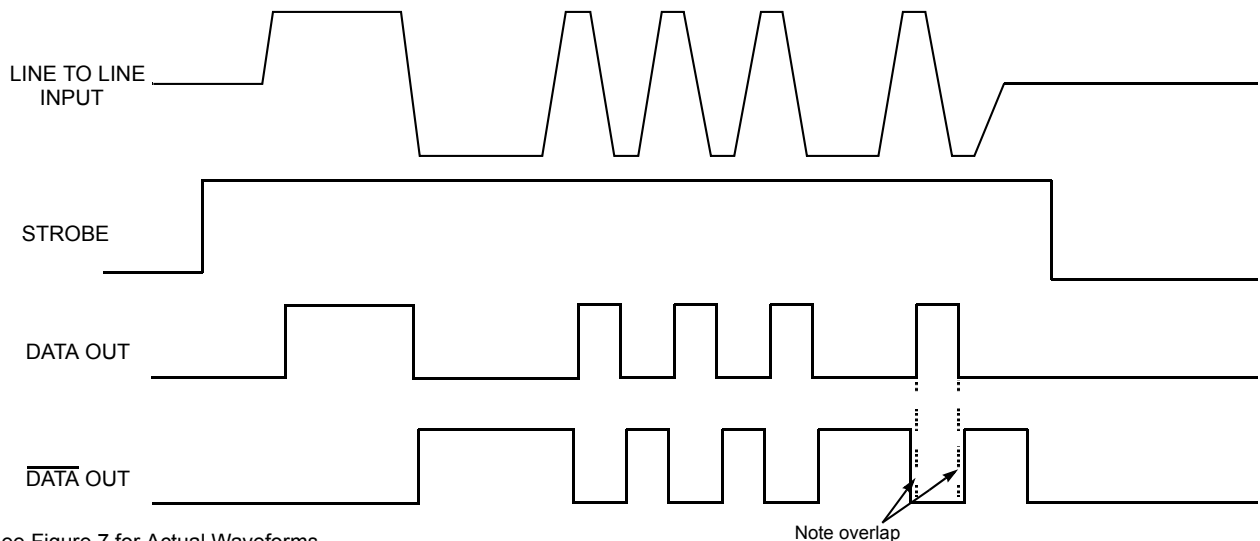

\* See Figure 7 for Actual Waveforms

**FIGURE 2 – RECEIVER LOGIC WAVEFORMS IDEALIZED \***

## ABSOLUTE MAXIMUM RATINGS

Operating case temperature	-55°C to +125°C
Storage case temperature	-65°C to +150°C
Power supply voltage	-0.3VDC to +7.0VDC
Logic input voltage	-0.3VDC to +5.5VDC
Receiver differential input	±10 V
Receiver input voltage (common mode)	±5V
Driver peak output current	650 mA
Total package power dissipation over the full operating case temperature range	2.0 Watts (Note: Normal operation conditions require one transmitter on and the other off at any given time)
Maximum junction to case temperature	10°C
Thermal resistance – Junction to case	5°C/W
Package Weight Plug-in Flat Package	16g (0.564oz) 12.5g (0.441oz)

## ELECTRICAL CHARACTERISTICS – DRIVER SECTION

### INPUT CHARACTERISTICS, TX DATA IN OR TX DATA IN (Notes 2 & 3 Apply)

Parameter	Condition	Symbol	Min	Typ	Max	Unit
"0" Input Current	V <sub>IN</sub> = 0.4V	I <sub>ILD</sub>	-	-0.2	-0.4	mA
"1" Input Current	V <sub>IN</sub> = 2.7V	I <sub>IHD</sub>	-	1	40	μA
"0" Input Voltage		V <sub>ILD</sub>	-	-	0.7	V
"1" Input Voltage		V <sub>IHD</sub>	2.0	-	-	V

### INHIBIT CHARACTERISTICS

"0" Input Current	V <sub>IN</sub> = 0.4V	I <sub>ILI</sub>	-	-0.2	-0.4	mA
"1" Input Current	V <sub>IN</sub> = 2.7V	I <sub>IHI</sub>	-	1.0	40	μA
"0" Input Voltage		V <sub>ILI</sub>	-	-	0.7	V
"1" Input Voltage		V <sub>IHI</sub>	2	-	-	V
Delay from TX inhibit, (0?) to inhibited output		t <sub>DXOFF</sub>	-	250	450	nS
Delay from TX inhibit, (1?) to active output		t <sub>DXON</sub>	-	150	250	nS
Differential Output Noise, inhibit mode		V <sub>NOI</sub>	-	2	10	mVp-p
Differential Output Impedance (inhibited)	Note 1	Z <sub>OI</sub>	2K	-	-	Ω

### OUTPUT CHARACTERISTICS

Differential output level (Point C-C')	R <sub>L</sub> = 70Ω	V <sub>O</sub>	18	21	25	Vp-p
Rise and fall times (10% to 90% of p-p output)		t <sub>r</sub>	100	200	300	nS
Output offset at point C-C' on Figure 5, 2.5 μS after midpoint crossing of the parity bit of the last word of a 660μS message	R <sub>L</sub> = 70Ω	V <sub>OS</sub>	-	-	±250	mVpeak
Delay from 50% point of TX DATA or TX DATA input to zero crossing of differential signal		t <sub>DTX</sub>	-	120	250	nS

## ELECTRICAL CHARACTERISTICS – RECEIVER SECTION

Parameter	Condition	Symbol	Min	Typ	Max	Unit
Differential Voltage Range (See Figure 5, point P-P <sup>7</sup> )	TXFMR 2.12:1	V <sub>IDR</sub>	-	14	20	V <sub>p-p</sub>
Common Mode Rejection Ratio (Note 3)		CMRR	45	-	-	dB

### STROBE CHARACTERISTICS (LOGIC "0" INHIBITS OUTPUT)

"0" Input Current	V <sub>S</sub> = 0.4V	I <sub>IL</sub>	-	-0.2	-0.4	mA
"1" Input Current	V <sub>S</sub> = 2.7V	I <sub>IH</sub>	-	1	+40	μA
"0" Input Voltage		V <sub>IL</sub>	-	-	0.7	V
"1" Input Voltage		V <sub>IH</sub>	2.0	-	-	V
Strobe Delay (Turn-on or Turn-off)		t <sub>SD</sub>	-	50	100	nS

### THRESHOLD CHARACTERISTICS (SINEWAVE INPUT)

Internal Threshold Voltage (Referred to the bus)	100KHz-1MHz	V <sub>TH</sub>	0.60	0.82	1.10	V <sub>p-p</sub>
--	-------------	-----------------	------	------	------	------------------

### OUTPUT CHARACTERISTICS, RX DATA AND RX DATA

"1" State	I <sub>OH</sub> = -0.4mA	V <sub>OH</sub>	2.5	3.7	-	V
"0" State	I <sub>OL</sub> = -4mA	V <sub>OL</sub>	-	0.35	0.5	V
Delay, (average) from differential input zero crossings to RX DATA and RX DATA output	50% points	t <sub>DRX</sub>	-	340	500	nS

## POWER DATA

### POWER SUPPLY CURRENTS – PER CHANNEL

Transmitter Standby	Note 4	I <sub>CC</sub>	-	18	30	mA
25% Duty Cycle			-	135	195	
50% Duty Cycle			-	250	345	
100% Duty Cycle			-	475	650	

### POWER SUPPLY VOLTAGE

Operating Power Supply Voltage Range		V <sub>CC</sub>	+4.75	+5.00	+5.50	V
--------------------------------------	--	-----------------	-------	-------	-------	---

#### NOTES:

- Power on or off, measured from 75KHz to 1MHz at point A-A' and transformer self impedance of 3KΩ minimum.
- V<sub>CC</sub> = 5 Volts ±0.5 V, bypassed by 220 μF (Tantalum recommended) Capacitor minimum. All measurements & specifications apply over the temperature range of -55°C to +125°C (case temperature) unless otherwise specified.
- When measured at point A-A' with ± 10 Volt peak, line to ground, DC to 2MHz.
- Typical power is measured with V<sub>bus</sub> at point A-A' = 7.0 V<sub>p-p</sub>.

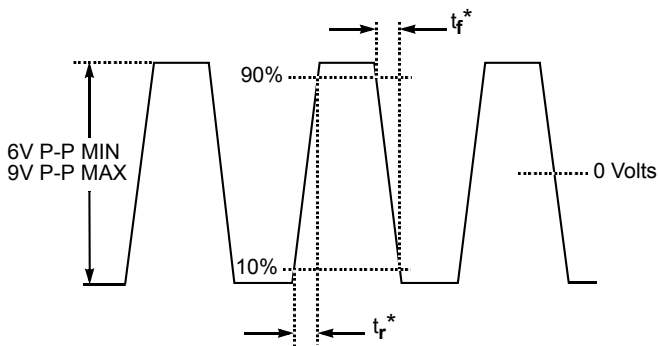

\* Rise and fall times measured at point A-A' in Figure 5

**FIGURE 3 – TRANSMITTER (TX) OUTPUT WAVEFORM**

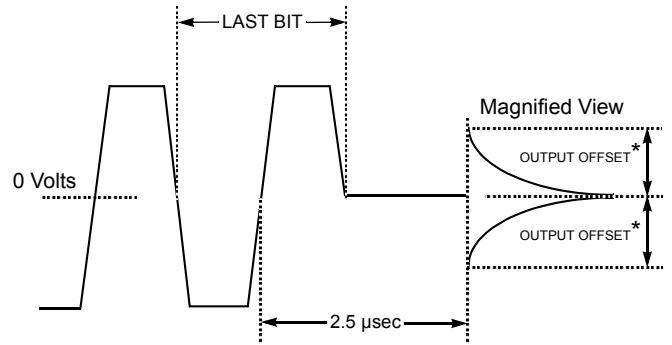

\*Offset measured at point C-C' in Figure 5

**FIGURE 4 – TRANSMITTER (TX) OUTPUT OFFSET**

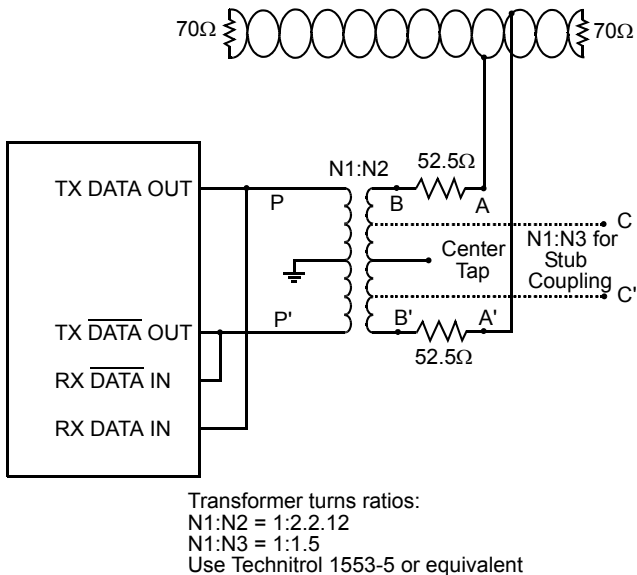

**FIGURE 5 – TYPICAL TRANSFORMER DIRECT CONNECTION**

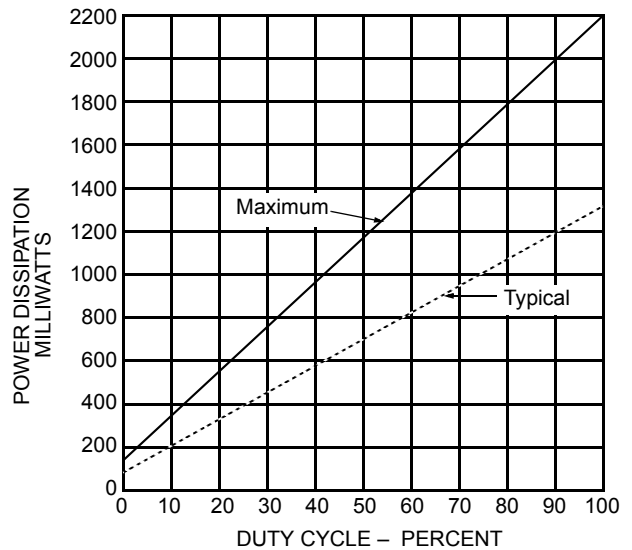

Note:  $V_{cc} = +5V_{DC}$ , Transformer ratio 1:2.12,  $V_{BUS}$  (Pt A-A') at 7.5VP-P.

**FIGURE 6 – POWER DISSIPATION VS. DUTY CYCLE**  
 (Total, hybrid with one channel transmitting and the other not powered)

**START OF WORD – 33 WORD TRANSMISSION**

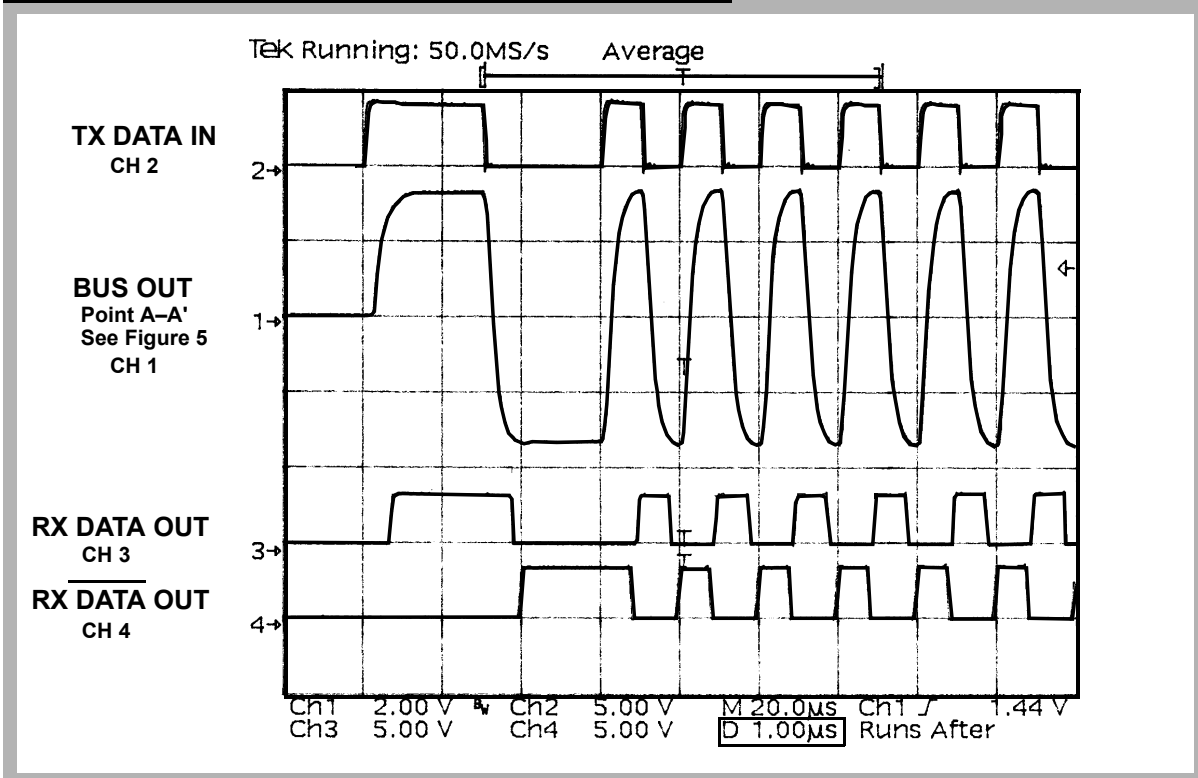

**END OF WORD – 33 WORD TRANSMISSION**

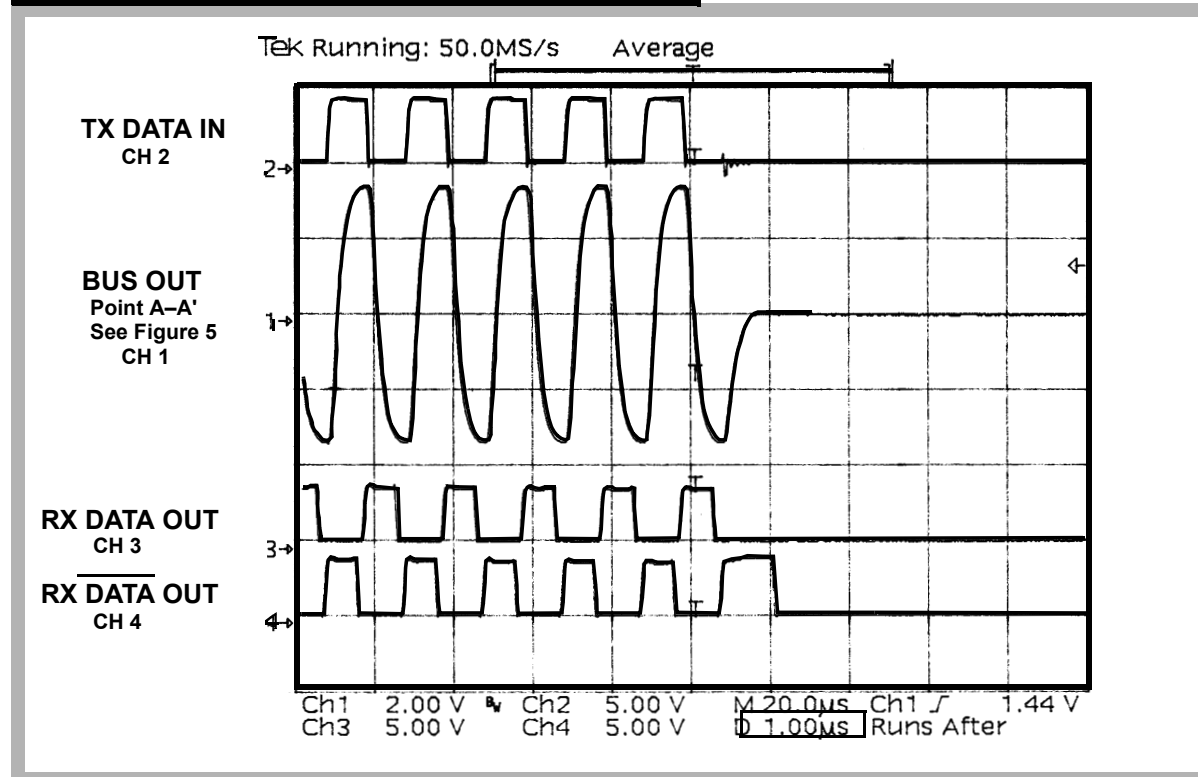

\* Oscilloscope used is a TEK TDS540 with Probe 6139A.

**FIGURE 7 ACTUAL HYBRID WAVEFORMS \* – 25°C TYPICAL**

## PACKAGE OUTLINES

**Model ACT4453 Dual In Line**

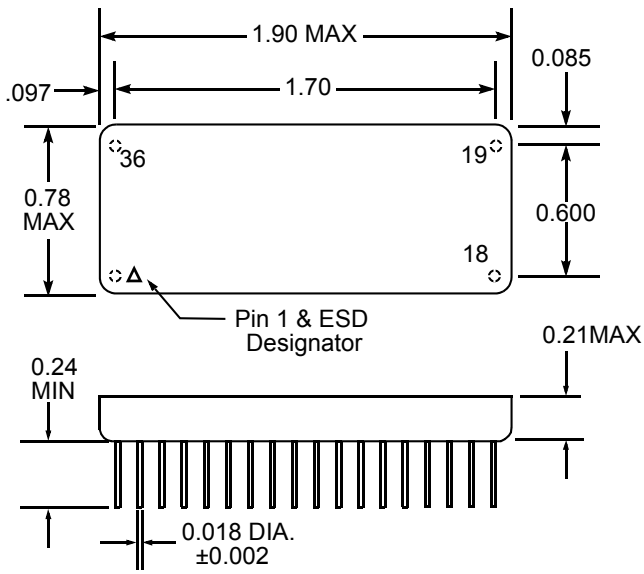

**Model ACT4453-2 Flat Pack**

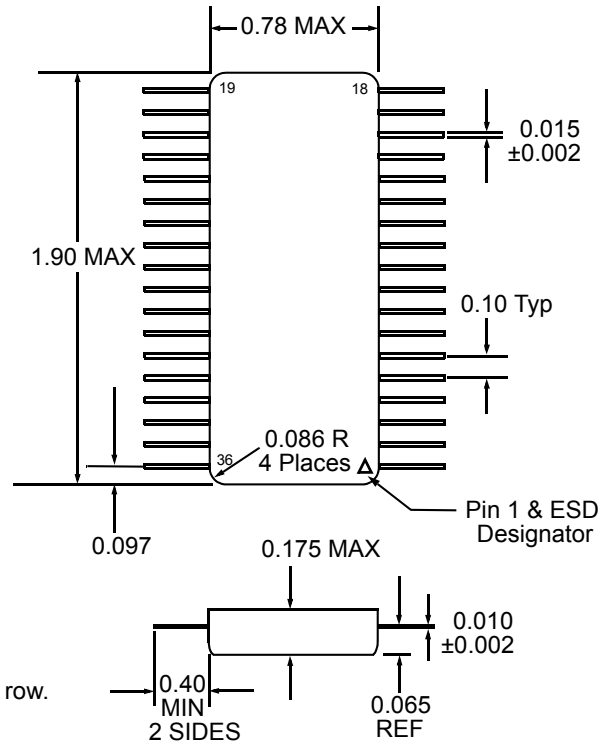

**Notes**

1. Dimensions shown are in inches
2. Pins are equally spaced at 0.100±0.002 tolerance, non-cumulative, each row.

## PIN NUMBERS & FUNCTIONS

Pin #	Function	Channel	Pin #	Function	Channel
1	TX DATA OUT	A	19	NC	-
2	TX $\overline{\text{DATA}}$ OUT	A	20	RX DATA IN	B
3	GROUND 1	A	21	RX $\overline{\text{DATA}}$ IN	B
4	NC	-	22	GROUND 3	B
5	RX DATA OUT	A	23	NC	-
6	STROBE	A	24	+5V	B
7	GROUND 2	A	25	INHIBIT	B
8	RX $\overline{\text{DATA}}$ OUT	A	26	TX DATA IN	B
9	CASE	-	27	TX $\overline{\text{DATA}}$ IN	B
10	TX DATA OUT	B	28	NC	-
11	TX $\overline{\text{DATA}}$ OUT	B	29	RX DATA IN	A
12	GROUND 1	B	30	RX $\overline{\text{DATA}}$ IN	A
13	NC	-	31	GROUND 3	A
14	RX DATA OUT	B	32	NC	-
15	STROBE	B	33	+5 V	A
16	GROUND 2	B	34	INHIBIT	A
17	RX $\overline{\text{DATA}}$ OUT	B	35	TX DATA IN	A
18	NC	-	36	TX $\overline{\text{DATA}}$ IN	A

## ORDERING INFORMATION

MODEL	DLA SMD #	SCREENING	PACKAGE
ACT 4453-7	-	Commercial Flow, +25°C testing only	Dual in Line
ACT 4453-2-7	-		Flat Package
ACT 4453	-	Military Temperature, -55°C to +125°C Screened in accordance with MIL-PRF-38534, Class H	Dual in Line
ACT 4453-2	-		Flat Package
ACT-4453-001-4 ACT-4453-001-5	5962-8952211XC 5962-8952211XA	In accordance with DLA SMD 5962-89522, Class H	Dual in Line
ACT-4453-201-4 ACT-4453-201-5	5962-8952211YC 5962-8952211YA	In accordance with DLA SMD 5962-89522, Class H	Flat Package
ACT-4453-001-1 ACT-4453-001-2	5962-8952212XC 5962-8952212XA	In accordance with DLA SMD 5962-89522, Class H	Dual in Line
ACT-4453-201-1 ACT-4453-201-2	5962-8952212YC 5962-8952212YA	In accordance with DLA SMD 5962-89522, Class H	Flat Package

### EXPORT CONTROL:

*This product is controlled for export under the U.S. Department of Commerce (DoC). A license may be required prior to the export of this product from the United States.*

[www.aeroflex.com/HiRel](http://www.aeroflex.com/HiRel)    [info-ams@eroflex.com](mailto:info-ams@eroflex.com)

#### Datasheet Definitions:

<i>Advanced</i>	<i>Product in Development</i>
<i>Preliminary</i>	<i>Shipping Non-Flight Prototypes</i>
<i>Datasheet</i>	<i>Shipping QML and Reduced HiRel</i>



Aeroflex Plainview, Inc. reserves the right to make changes to any products and services described herein at any time without notice. Consult Aeroflex or an authorized sales representative to verify that the information in this data sheet is current before using this product. Aeroflex does not assume any responsibility or liability arising out of the application or use of any product or service described herein, except as expressly agreed to in writing by Aeroflex; nor does the purchase, lease, or use of a product or service from Aeroflex convey a license under any patent rights, copyrights, trademark rights, or any other of the intellectual rights of Aeroflex or of third parties.

Our passion for performance is defined by three attributes.



Solution-Minded



Performance-Driven



Customer-Focused