

V.42 / MNP[®] 5 Microcontroller

GENERAL DESCRIPTION

The XR-2442 is a dedicated microcontroller that provides command control for the XR-2400 V.22bis modem chip set. The XR-2442 provides control for CCITT recommended V.42 error correction, including LAPM and MNP 2-4 protocols, with MNP class 5 data compression included for greater compatibility. Also supported are the standard 'AT' commands.

The system architecture of the XR-2442 allows the actual command sets for the 'AT', MNP, and LAPM to reside external to the XR-2442, allowing ease of customization. Exar provides these command sets to use as is, or modify to the requirements of your design.

The XR-2442 operates from a single +5 volt power supply, offering low power consumption through CMOS technology.

FEATURES *

- V.22bis/V.22/Bell 212A/Bell103 Modem
- Error Free Data Transfer
 - LAPM
 - MNP 2-4
- Increased Data Throughput by MNP 5 Data Compression
 - 4800 BPS Throughput
- 'AT' Command Control
 - Easily Modified, Exar Supplied Source Code

**(Apply when used with XR-2400 V.22bis modem chip set)*

APPLICATIONS

- Error Free Modem Applications
- Stand-Alone Modems
- Smart Modems
- Laptop Modems

PIN ASSIGNMENT

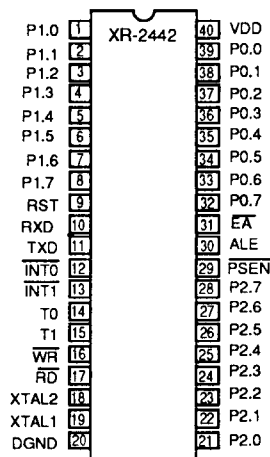

(For other pin assignment diagrams, refer to the end of this datasheet)



ABSOLUTE MAXIMUM RATINGS

Power Supply	-0.3V to +7V
Input Voltage	-0.7V to (VDD +0.3V)
DC Input Current	±10mA
(any input)	
Power Dissipation (Package Limitation)	1W
Derate above 25°C	
Storage Temperature Range	-65°C to +150°C

ORDERING INFORMATION

Part Number	Package	Operating Temperature
XR-2442CP	40 Pin Plastic Dip	0°C to 70°C
XR-2442CJ	44 Pin PLCC	0°C to 70°C
XR-2442CQ	44 Pin QFP	0°C to 70°C

SYSTEM DESCRIPTION

The XR-2442, when coupled to the XR-2400 V.22bis modem chip set, allows the implementation of an error-free, increased throughput V.22bis modem.

The XR-2442 is just one in the family of controller options for the XR-2400 V.22bis modem chip set, including:

FUNCTION	CONTROLLER
'AT'	8031
'AT'/MNP 2- 5	XR-2403B
'AT'/V.42/MNP 5	XR-2442
'AT'/V.42/V.42bis/MNP 5	XR-2443

XR-2442

ELECTRICAL CHARACTERISTICS

Test Conditions: $T_A = 25^\circ\text{C}$, $V_{DD} = 5V \pm 10\%$, $F_{CLK} = 11.0592\text{MHz} \pm 0.05\%$, unless otherwise specified.

SYMBOL	PARAMETERS	MIN	TYP	MAX	UNITS	CONDITIONS
V_{DD}	Power Supply Voltage	4.5	5	5.5	V	
I_{DD}	Power Supply Current		18	22	mA	
V_{IH}	Input High Voltage	1.8			V	Except XTAL1 and RST
V_{IH}	Input High Voltage	3.5			V	XTAL 1 and RST
V_{OH}	Output High Voltage	2.4			V	Ports 1,2,3 $I_{OH} = -60\mu\text{A}$
V_{OH}	Output High Voltage	2.4			V	Port 0 (External Bus Mode) ALE, $\overline{\text{PSEN}}$ $I_{OH} = -800\mu\text{A}$
V_{OL}	Output Low Voltage			0.45	V	Ports 1,2,3, $I_{OL} = 1.6\text{ mA}$
V_{OL}	Output Low Voltage			0.45	V	Port 0, ALE, $\overline{\text{PSEN}}$ $I_{OL} = 3.2\text{ mA}$
I_{IH}	Input High Current			± 10	μA	$0.45\text{V} \leq V_{IN} \leq V_{DD}$ (Leakage)
I_{IL}	Input Low Current			-50	μA	$V_{IN} = 0.45\text{V}$

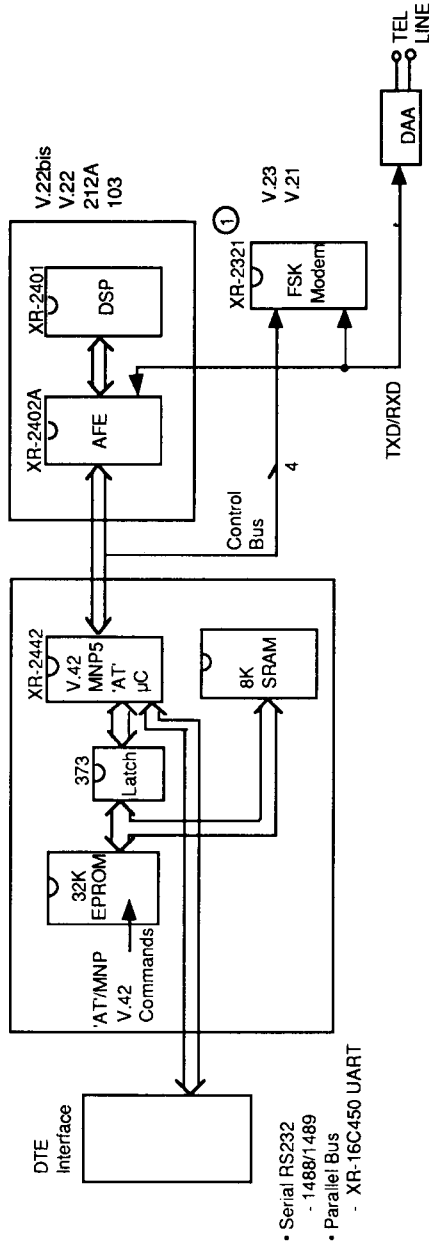

① Only needed for applications requiring V.21/V.23 modes (European). For V.21 only applications, use the XR-2100 V.21 FSK modem (pin-to-pin replacement to XR-2321).

Figure 1. 2400 BPS Modem with V.42 / MNP 5 Block Diagram

XR-2442

SYSTEM OPERATION

A typical application utilizing the XR-2442 to support the XR-2400, V.22bis chip set, is shown in Figure 1. The XR-2400 provides the complete modem data pump function for:

V.22bis	2400 BPS
V.22	1200 BPS
V.23*	1200 BPS/75 BPS
V.21*	300 BPS
212A	1200 BPS
103	300 BPS

* Supported by the XR-2321

Command control is supported by the XR-2442 for:

MNP 2-4	Microcom Error Correction
MNP 5	Microcom Data Compression
LAPM	CCITT Recommended V.42
	Error Correction
'AT'	Industry Standard 'AT'

Although the XR-2442 does provide complete command control, the actual commands for the various modes reside in an external EPROM - 27C256, 32k

Byte. With this architecture and an Exar supplied command set, maximum flexibility is offered. The command set can be used as is, or custom tailored to a particular design.

The unique architecture utilized by the XR-2400 and command controller allow the **same** hardware (PCB) to support several different types of 2400 BPS modems. By changing available pin-to-pin microcontrollers, the 2400 BPS modem types listed in Table 1 are all possible with the same printed circuit board. As mode types are changed by the μ C, EPROM supported command sets and SRAM size change and/or elimination are also required. In each case Exar provides complete production worthy, command sets which may be used as is, or modified to meet specific application requirements. To aid in software modifications, Table 2, 3 and 4 list the XR-2442 memory mapping, indicating customer usable regions.

External memory modifications requiring μ C (XR-2442) support will of course need entry/re-entry point information. This point is important as the XR-2442 contains program memory with EXAR proprietary V.42/MNP 5 functions not accessible externally (fusible link protected) or available to EXAR customers.

2400 BPS Modem Type	Microcontroller Part Number	External Memory Requirements (Bytes)	
		EPROM	SRAM
'AT'	8031 (Generic ROMLESS μ P)	16k	NONE
'AT' / MNP 2-5	XR-2403B	16k/32k	8k
'AT' / MNP5/V.42	XR-2442	16k	8k / 32 k
'AT'/MNP5/V.42/ V.42bis	XR-2443	32k	32k

Table 1. 2400 BPS Modem Options / μ C, EPROM, RAM Requirements

ENTRY POINTS AND MEMORY MAPPING

Status / Mode Setting Memory Locations

Status	Location	Description
SPD_FLG	20 H.7	Speed Conversion Enable Flag
BK_PRE	51 H	Break Prescaler Timer
BK_TMR	52 H	Break Timer (Only in Normal Mode)
MRCVP2	803BH	Disconnect to Check Auto-Reliable Fallback Mode
PASS_B	9D14H	Escape Code Checking Byte in Speed Conversion Mode
SPEED	9D15H	Speed Indicator For All Modes 0 - 9600 BPS 1 - 4800 BPS 2 - 2400 BPS 3 - 1200 BPS 4 - 300 BPS
Z_BUF	9D16H	Auto Reliable Fallback Character
BACK_RAM	9D1AH	Starting Address for Command Buffer Backup
OPT_P	9D50H	Output Port Selection Option (FOFF H to 40 FFH) This Parameter is Initialized Immediately After Power On and constantly monitored by MNP Module
MNP_S	9E22H	Reliable Link Indicator

Function Call Locations - V.42/ MNP 5

Function	Location	Description
SCTINT_1	0006H	Interrupt 0 Jump-In Point.
SCRINT_1	0016H	Interrupt 1 Jump-In Point.
SPINT_1	0026H	Serial Port Interrupt Jump-In Point.
MSG_CP	0030H	Exar Copyright Message.
P_ECRAM_1	0060H	After Escape MNP Re-Entry Point.
MSG_CPY	0063H	Exar Copyright Calling Subroutine.
MNP_IN	0066H	MNP Program Immediate Re-Entry Point for modifying MNP Program.
SPD_INM	0069H	Speed Conversion Program Jump-In Point.
INI_SPDM	006CH	Speed Conversion Initialization Routine.
V21_IN_1	006FH	300 BPS Speed Conversion Timer Set-Up.

EC_MAIN 0080H Calling Main MNP Program. This is the only location which will initiate the MNP program.

XR-2442 Re-Entry Points

Function	Location	Description
PWR_ONS	C000H	Power On
OUT_SCT	C003H	Interrupt 0
OUT_T0	C006H	Timer 0
OUT_SCR	C009H	Interrupt 1
OUT_T1	C00CH	Timer 1
OUT_SP	C00FH	Serial Port Interrupt
OUT_T2	C0012H	Timer 2
MNP_OUT	C0015H	MNP Program Intermediate Point
CHK070S	C01BH	MNP 'ESC' Jump Out Point
DISCONNECTS	C01EH	MNP Disconnect
ON_LOOPS	C021H	Auto-Reliable Fallback Point.
SPD-OUTS	C024H	Speed Conversion Jump Out Point.
V21_INS	C027H	Call Speed Conversion ASM for 300 BPS.
SPD_TXD	C02AH	Put TXDATA to Modem Chip.
SPD_RXD	C02DH	Get RXDATA From Modem Chip.

RAM Locations

The stack in the 'AT' program starts from 0C0H on page 1 and occupies 64 bytes of space. Internal RAM on page 0 has 23 bytes and page 1, 64 bytes of free indicator space.

The external RAM data memory is as follows:

- 1) Error Control 8000H-8FFFH
- 2) Data Compression Buffer 9000H-93FFFH
- 3) FAX / Remote Buffer 9400H-95FFFH
- 4) Available for use 9600H-97FFFH
- 5) V.42 9800H-98FFFH
- 6) Break Buffer 9A00H-9AFFH
- 7) DTE TX Buffer 9B00H-9BFFFH
- 8) DTE RX Buffer 9C00H-9CFFFH
- 9) Misc. Registers 9D00H-9DFFFH
- 10) MNP RAM Backup Buffer 9E00H-9EFFH
- 11) 'AT' RAM Backup Buffer 9F00H-9FFFH

Note: For program control, the XR-2442 backs up the entire 256 bytes of internal RAM into external RAM before jumping into or out of the MNP program. The 'AT' program RAM is 9F00H and MNP program RAM is 9E00H-9EFFH.

XR-2442

Interrupt Vectors

The XR-2442 brings out all interrupt vectors to the external program. This allows easy customer modification of service routines to suit a particular application. The interrupt vectors of the XR-2442 are as follows:

```

        ORG 0
        LJMP PWR_ONS; Jump to Power On
           Set Up Routine
EXT_INT0: ORG 3H
           ;Interrupt 0 for SCT
        LJMP OUT_SCT
SCTINT1:  ORG 0BH
           ;Timer 0 Interrupt
        LJMP OUT_TO
           ;Timer 0 Interrupt
EXT_INT1: ORG 13H
           ;Interrupt 1 for SCR
        LJMP OUT_SCR
SCRINT_1: ORG 1BH
           ;Timer 1 Interrupt
        LJMP OUT_T1
           ;Timer 1 Interrupt
        ORG 23H
    
```

```

INT_SER:  ;Serial Port Interrupt
        LJMP OUT_SP
SPINT_1:  ;Serial Port Interrupt
        LJMP SPINT
        ORG 2BH
T_INT2:   ;Timer 2 Interrupt
        LJMP OUT_T2
    
```

XR-2442 PROGRAM/DATA MEMORY MAPS

Tables 2, 3 and 4 show the ROM and RAM memory maps for XR-2442.

As it is indicated in Table 2, 32K bytes of EPROM is assigned to 'AT' command firmware. This section of the ROM is located between 8000H and FFFFH address locations of the memory space.

LAPM, MNP 2-4 and MNP5 code is masked in the microcontroller (XR-2442), and resides in the 8K bytes of memory, between address locations 0000H and 1FFFFH.

Table 3 shows the RAM map, in which the space between 0000H and 002CH address locations is used for modem chip address. Table 4 shows the modem chip address assignment.

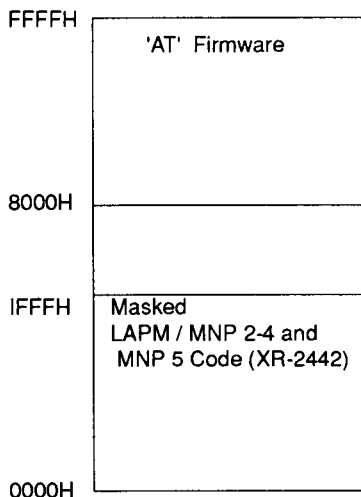

Note: 27C256 = 32K Byte EPROM

Table 2. XR-2442 ROM Map

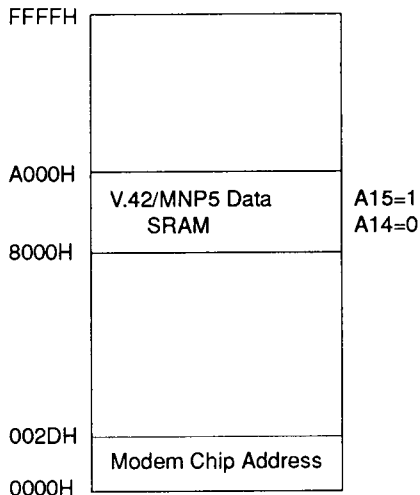

Table 3. XR-2442 RAM Map

MODEM CHIP	RAM ADDRESS	\overline{CS}
XR-2402A	0000H - 0003H	A15=0
XR-2321	0028H - 002CH	A5=1 and A15=0
XR-2100	0028H - 0029H	A5=1 and A15 =0

Table 4. Modem Chip Address

Also RAM space between 8000H and 9FFFH is assigned for V.42 and MNP 5 data. RAM locations between A000H and FFFFH, as well as RAM locations between 002DH and 7FFFH are available for I/O ports such as LED, EIA, etc.

V.42 / MNP OPERATION

The XR-2442 when coupled with the XR-2400 V.22bis modem chip set allows the implementation of an **error-free, increased throughput** 2400 BPS modem. To gain an understanding of V.42/MNP 5 modes of operation, the following basic information has been included. A basic understanding of error correction techniques, flow control, speed buffering, and data compression will allow the designer to better understand a V.42/MNP5 modems capabilities and how to best utilize them.

V.42 is a CCITT recommended error correction protocol which allows asynchronous DTE's (Data Terminal Equipment) to communicate error-free with other such equipped modems.

The actual error correction protocol used in V.42 is an HDLC (High-Level Data Link Control) based protocol called LAPM, for **Link Access Procedure for Modems**. For additional detailed information beyond the following basic description, refer to the CCITT Recommendations, Series V, 'Data Communication Over the Telephone Network'. The latest version is known as the '**Blue Book**' (Blue Covers) or Series, dated 1988 (Melbourne), a recent update from the '**Red Book**'.

V.42 Basic Operation/Features

- HDLC-based error correction protocol-LAPM
- Asynchronous (Async or 'start/stop') DTE Communication - error free

- Actual line transmission is synchronous (sync)- no start or stop bits (stripped from data), however initial handshake, subsequent to modem handshake is async

• Error Correction

- Data sent in 'frames' or blocks with a nominal size (default) of 128 Octets (Octet - 8 bit) data frames
- Start/Stop bit elimination from data creates an actual data throughput improvement, roughly 120% of nominal. 2400 BPS becomes about 2900 BPS
- Encoded information added to data frame for receiver to 'decode' and determine if the block was error free. 16-bit cyclic redundancy (CRC) methods are used for data encoded information to (1) indicate correct data and (2) recognize imperfect data frame
- Retransmission (automatic) of determined imperfect frames to ensure perfect data is received

V.42 operation is found to be virtually identical (specifically to variable parameters) to that of MNP reliable or normal modes of operation. For this reason the MNP command set is also used for V.42 variables control.

MNP OPERATION

MNP, or Microcom Networking Protocol was developed by Microcom, Inc., a modem manufacturer. Since conception, it has been in a constant state of update/improvement. For this reason 'classes' of operation emerged to signify each major update or improvement.

Relative to V.22bis or 2400 BPS modems, up to class or level 5 has become the 'standard'.

XR-2442

MNP CLASSES

(Throughput data is based on **2400 BPS** line speed).

Class 1 A half duplex protocol and not included in many new designs. Throughput was about 70% or 1690 BPS. The XR-2442 does not support this class.

Class 2 Asynchronous operation with byte oriented data formatting. Throughput is roughly 84% of nominal or about 2000 BPS.

Class 3 Conversion to synchronous, bit oriented data handling is transmitted in blocks consisting of 1 to 64 characters. Throughput is about 108% or 2600 BPS. Class 3 was the "industry standard" in 1987.

Class 4 Basic characters are the same as Class 3 but block size is dynamic, up to 256 Bytes, (flexible size is based on data transmission quality). Throughput is 120% or 2900 BPS.

Class 5 Includes Class 3 and 4 with data compression techniques added. The compression effectiveness is dependent on the type of data, but typical throughput enhancements are up to 200% or 4800 BPS.

ERROR CORRECTION

Modem users have come to expect sophisticated circuitry like adaptive equalization for varying phone characteristics and retrain modes for ensuring continued optimal performance. These techniques dramatically improve performance characteristics such as BER vs S/N, the probability of errors when the modem signal is in the presence of noise. But try as they may, BER values do not go to zero, especially as modem speeds increase.

The previously mentioned techniques are aimed at improving the modem data pump through analog (or digitally synthesized) circuitry. Techniques are becoming popular for not only improving, but virtually eliminating data errors through protocols implemented in the modems command microcontroller (μ C). Prior to these 'hardware' based schemes, error correction provided in the applications software was

available, such as XMODEM or Kermit for asynchronous file transfer. In mainframe environments, SDLC or HDLC schemes were used.

Software based error correction schemes do however have their disadvantages. One important one being reduced data throughput. The throughput performance varies, but all schemes reduce data transfer below its nominal rate. Typical values of 91% are common, equating to only about 2200 BPS for a 2400 BPS modem.

The hardware based error correction protocols supported by the XR-2442 are those as specified by the **CCITT**, **LAPM**, and **MNP**. These schemes convert asynchronous data to be transmitted to a synchronous format (start and stop bits are stripped) for a bit-oriented protocol. Throughput values again vary, however typical values of 108% for the lower MNP Class 3 and 120% for MNP Class 4 or LAPM. These equate to roughly 2600 - 2900 BPS for 2400 BPS modems.

Actual error correction is based on adding information to the block-oriented data, through a 16-bit CRC (Cyclic Redundancy Check) calculation. The receiving side calculates CRC values for each block and if found to be incorrect, a retransmission of that block will be requested.

Typical frame sizes for LAPM are 128 Octets (8-bit start/stop bit stripped characters).

DATA COMPRESSION

The CCITT recommendation for V.42 only specifies error correction modes, as provided by LAPM and MNP 2-4. Modem controller protocols have advanced to the point where in addition to providing error-free data transfer, they can also offer other significant enhancements. One very significant enhancement is the addition of data compression operation. Simply put, this technique dramatically enhances the actual data throughput of the modem.

This data compression scheme, MNP5, although not specifically part of the V.42 recommendation, has been included in the XR-2442 to serve only as a further enhancement to the XR-2442 based modems.

MNP Class 5 is the protocol for **data compression**. It is by far the most accepted protocol for this function. CCITT recommendations are adding a data compression mode to V.42, called **V.42bis**. The **XR-2443** supports the CCITT recommended **BTLZ** data compression.

MNP 5 data compression offers the XR-2400 V.22bis modem chip set roughly an 100% increase in throughput, or 200% of nominal. This translates to a maximum modem throughput of 2400 BPS x 2 = 4800 BPS.

MNP 5 techniques utilize a scheme which abbreviates redundant data characters for a much higher transmission efficiency or throughput increase. Because of its dependency on redundant characters the amount of improvement will vary. Typical improvement values are in the range of 75 to 125%, or 4200 to 5400 BPS for 2400 BPS modems.

FLOW CONTROL

As previously outlined, a method for regulating the flow of data to be transmitted is necessary when DTE data rates exceed line rates. Figure 2 illustrates a basic modem connection and helps illustrate where flow controls fit in.

XR-2442 V.42/MNP5 FUNCTIONS AND COMMANDS

The XR-2442 with external EPROM provides control for the following major functions:

FUNCTION	DESCRIPTION
• 'AT' Command Control	Provides 'AT' Command Set Control
• MNP Level 2-4	Provides error correction for 100% perfect data transfer.
• MNP Level 5	Allows roughly a 100% increase (4800 BPS for V.22bis mode) in data throughput, though data compression techniques.
• V.42 (LAPM)	100% perfect data transfer
• Speed Conversion	Maintain up to 9600 BPS DTE terminal speed for 300 BPS to 2400 BPS line speeds, both for LAPM/MNP and non-error correcting connections.

Flow control can be under **hardware** or **software** control.

HARDWARE FLOW CONTROL

Hardware Flow Control allows the modem to lower or raise its CTS (Clear to Send) line to the DTE. This provides an ON/OFF control of data flow from DTE to modem. If the modem data buffer becomes full it lowers the CTS line to stop transmit data flow to allow the modem to "catch-up".

SOFTWARE FLOW CONTROL

An alternative to hardware flow control is control by software, known as **Xon/Xoff**. This is accomplished by special characters inserted into the data stream to start and stop data flow. **Control Q (^Q)** is used to start or restart data flow and **Control S (^S)** to stop data flow.

Three different variations of Xon/Xoff control modes are:

- Send Only
- Normal
- Passthrough

XR-2442

PROTOCOL NEGOTIATION

The XR-2442 supports error correcting or reliable modes of operation for not only LAPM, but also MNP type protocols. Also, although data compression operation is not specified by CCITT V.42 specifications, it has been included through MNP 5 for increased compatibility. Because of these multiple protocols supported, the XR-2442 offers two temporary protocol negotiation modes:

- 1) **ATM0** Default Mode. This command selects an automatic protocol negotiation mode. **First LAPM** negotiation will be attempted. If not possible, MNP 2-4,5 operation will be negotiated. The highest possible class of MNP operation will be negotiated (Compression negotiation will be attempted depending upon the setting of the %C command). If the remote modem does not support error correction, normal 2400 BPS (or 1200/300 BPS) operation will be supported.

- 2) **ATM1** This command will **disable LAPM** operation. Here only MNP 2-5 and non-error correcting modes of operation will be supported.

The following is a command set summary for the XR-2442. Provided are:

- 1) Basic Connection/Dialing Commands
- 2) Dialing Modifiers
- 3) Standard Hayes 'AT' Command Set
- 4) 'S' Register Descriptions/Functions. These registers are used for controlling the value or function of various 'AT' commands.
- 5) MNP/LAPM Commands. The entire list represents the MNP command set. Most of the MNP commands also apply to LAPM, with the exceptions indicated.

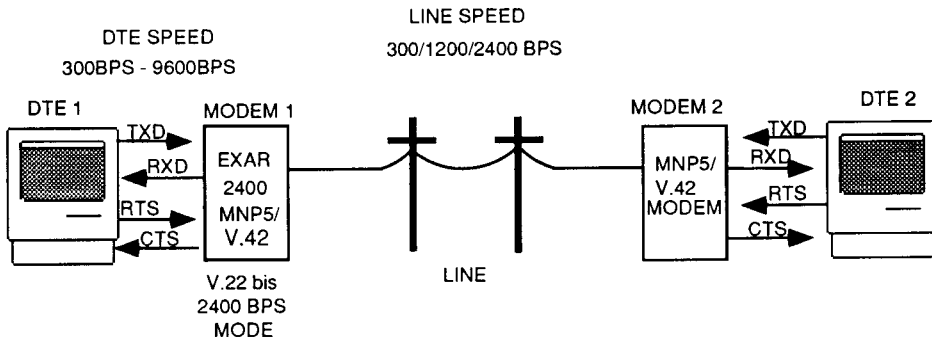

Figure 2. Basic Modem Test Configuration For Throughput

COMMAND	DESCRIPTION / RANGE - SIZE
A/ AT ATA ATB0 ATB1 ATB2 ATD ATDP ATDT	Execute previous command, without striking <CR> key Attention Answer Immediate CCITT V.22 mode Bell 212A mode DEFAULT V.23 mode Dial Command Dial Using pulse dial Dial Using DTMF tone dial DEFAULT
The following 8 modifiers will dial using the previously used technique (pulse or tone), or the T or P command can be added after the D (dial) command. 0-9 A B C D * #	
ATDW ATD@ ATD! ATDR ATDS=n ATD/ ATD; ATD, ATE0 ATE1 ATH0 ATH1 ATIO ATI1 ATI2 ATI3 ATLO ATL1 ATL2 ATL3 ATM0 ATM1 ATM2 ATM3 ATO ATO1 ATQ0 ATQ1 ATSn? ATSn= ATV0	Wait for Dial Tone for Period Set by S7 Register Quiet Answer: Wait for 5 Seconds of Silence Before Dialing Hookflash: Commonly Used PBX Systems Reverse Answer Mode Dial Stored Number when n= 0-3 Wait 0.125 Seconds Return to Command Mode After Dialing Pause for Time Set by S8 Register Command Echo Disabled Command Mode Echo Enabled DEFAULT Go On Hook (Open Relay) Go Off Hook (Close Relay) Identification Code Identification Code "OK" Response if Checksum Verifies EXAR EPROM Revision Date Lowest Volume Setting Same as ATLO Medium Volume Setting DEFAULT Maximum Volume Speaker Always Off Speaker On Until Carrier is Detected DEFAULT Speaker Always On DTMF Tones are not Heard, but Speaker is on Until Carrier Detected Originate Immediate or Return to Data Mode Request a Retrain When in V.22bis Mode Provide Result Codes DEFAULT Disable Result Code Provide S Register Value Set S Register Value Terse (and Verbose) Responses, affected by \Vn

XR-2442

NUMERIC	DESCRIPTION / RANGE - SIZE	
V1		
0	OK	Command Executed
1	CONNECT	Connection at 0 to 300 BPs
2	RING	Ring Signal Detected
3	NO CARRIER	Carrier Signal not Detected
4	ERROR	Error
5	CONNECT 1200	Connection at 1200 BPS
6	NO DIALTONE	No DialTone Detected
7	BUSY	Busy Signal Detected
8	NO ANSWER	No Silence Detected
10	CONNECT 2400	Connection at 2400 BPS
11	CONNECT 4800	Connection at 4800 BPS
12	CONNECT 9600	Connection at 9600 BPS
14	CONNECT 19200	Connection at 19200 BPS
V1		
22	CONNECT 1200/REL 4	MNP Class 4 Link
22	CONNECT 1200/REL 5	MNP Class 5 Link
23	CONNECT 2400/REL 4	MNP Class 4 Link
23	CONNECT 2400/REL 5	MNP Class 5 Link
22	CONNECT 1200/V.42	V.42 Link
23	CONNECT 2400/V.42	V.42 Link

COMMAND	DESCRIPTION / RANGE - SIZE
ATV1	Verbose Response DEFAULT . See ATV0 for Responses
ATX0	Enable Result Codes 0-4
ATX1	Enable Result Codes 0-5, 10
ATX2	Enable Result Codes 0-6, 10
ATX3	Enables Result Codes 0-5 and 7 and 10
ATX4	Enables Result Codes 0-10 DEFAULT
ATY0	Disable Long Space Disconnect DEFAULT
ATY1	Enable Long Space Disconnect
ATZ0	Software Reset, Restore S Register from profile location 0 in NVRAM
ATZ1	Restore S Registers From Profile Location 1 in NVRAM
AT&C0	EIA Carrier Line Always Forced on DEFAULT
AT&C1	EIA Carrier Line Follows Data Carrier
AT&D0	DTR Always on DEFAULT
AT&D1	Modem Goes to Command Mode When DTR Goes Off
AT&D2	Modem Goes on HOOK and Returns to Command Mode When DTR Goes Off
AT&D3	Modem Initializes When DTR Goes Off
AT&F	Fetch S Registers From EPROM for Factory Default
AT&G0	No Guard Tone DEFAULT
AT&G1	550 Hz Guard Tone Enabled
AT&G2	1800 Hz Guard Tone Enabled
AT&J0	RJ-11 Select DEFAULT
AT&K0	Flow Control Disabled
AT&K1	No Function
AT&K2	No Function
AT&K3	RTS/CTS Flow Control Default
AT&K4	Xon/Xoff Flow Control
AT&K5	Xon/Xoff Pass Through
AT&L0	Switched Line Select DEFAULT
AT&L1	Leased Line Select
AT&M0	Asynchronous Mode DEFAULT
AT&M1	Synchronous Mode With Asynchronous Dial
AT&M2	Synchronous Mode and Dial the Stored Number Immediately
AT&M3	Synchronous Mode With DTR Controlling Data/Talk
AT&P0	US Make/Break Ratio For Pulse Dialing DEFAULT
AT&P1	UK Make/Break Ratio For Pulse Dialing
AT&Q0	Direct mode (same as Hayes)
AT&Q1	Same as &M1
AT&Q2	Same as &M2
AT&Q3	Same as &M3
AT&Q5	Error Control Mode
AT&Q6	Normal Mode
AT&R0	Clear To Send (CTS) Follows RTS DEFAULT
AT&R1	CTS Always On
AT&S0	Data Set Ready (DSR) Always on DEFAULT
AT&S1	DSR Normal
AT&T0	Terminate Test in Progress DEFAULT
AT&T1	Initiate Local Analog Loopback For Time Set by Register S18

XR-2442

COMMAND	DESCRIPTION / RANGE - SIZE
AT&T2	Not Defined
AT&T3	Initiate Digital Loopback for Time Set by Register
AT&T4	(Not Supported)
AT&T5	Disable Remote Digital Loopback (RDLB) Response
AT&T6	Initiate RDLB
AT&T7	Initiate RDLB with Self Test
AT&T8	Initiate ALB with Self Test (for Direct / Normal Mode only)
AT&W0	Write User Profile 0 into NVRAM
AT&W1	Write User Profile 1 into NVRAM
AT&X0	Modem Provides Transmit Clock
AT&X1	DTE Supplies Transmit Clock (Not Supported)
AT&X2	Slave Clock Mode (Not Supported)
AT&Y0	Power Up Recall User Profile 0
AT&Y1	Power Up Recall User Profile 1
AT&V	List Configuration both Active and Stored
AT&Z m=An	Store Telephone Number into NVRAM (XL93C46) where: <i>m</i> is the number location (0-3) <i>A</i> is <i>P</i> or <i>T</i> (Pulse or Tone) <i>n</i> is the telephone number

COMMAND	LAPM Yes/No	DESCRIPTION/RANGE - SIZE	FUNCTION
ATM0*	Y	LAPM Enabled	Attempt LAPM Negotiation Do Not Attempt LAPM Negotiation
ATM1	N	LAPM Disabled	
AT \ N0	Y	Normal	Transmit Block Size
AT \ N1	Y	Direct	
AT \ N2	Y	MNP 2-5/Reliable	
AT \ N3	N	MNP 2-5/Auto Reliable	
AT \ N4	Y	V.42 Mode	
AT \ N5	Y	V.42 Mode Auto Reliable	
AT \ N6	Y	V.42 / MNP 2-5 Reliable	
AT \ N7*	Y	V.42 / MNP 2-5 Auto Reliable	
AT \ A0	N	64 Characters	
AT \ A1	N	128 Characters	
AT \ A2	N	192 Characters	
AT \ A3*	N	256 Characters	
AT%An	Y	n = 0-127 ASCII	
AT \ L0*	N	Stream Link	
AT \ L1	N	Block Link \L1 = \L0	
AT \ O	N	Initiate Reliable Link After Escape Command Independent of Modem Initial mode (ANS or ORG)	Originate Reliable Link
AT \ U	N	Accept Reliable Link after Escape Command request from Initiator of Link	Accept Reliable Link
AT \ Y	N	Establish Reliable Link after Connecting in Normal Mode	Switch to Reliable Mode
AT \ Z	N	Switch to Normal Mode After Establishing a Reliable Link	Switch to Normal Mode
AT % C0	Y	Compression Disabled	Compression On/Off Control
AT % C1*	Y	Compression Enabled	
AT \ V0	Y	Standard Non-MNP Result Codes	Result Code Form
AT \ V1*	Y	Modified MNP Result Codes (As Listed Below)	
AT \ Bn	Y	N = 0 - 9 (100ms Increments) Used in Normal Mode Default = 3, Error Control Mode Always 300ms	Transmit Break for Normal Data Mode
AT \ C0*	Y	Does not buffer Data Default	Set Auto-Reliable Buffer Break Control
AT \ C1	Y	Buffers All Data on Answering Modem until 200 Characters (Non-Sync) are Returned	
AT \ C2	Y	Does Not Buffer Data on Answering Modem, according to % An to fall back	Break Control for Reliable Data Mode
AT \ K1	Y	"Destructive" signaling regardless of its sequence in data sent and received; data in process at time is destroyed	

XR-2442

COMMAND	LAPM Yes/No	DESCRIPTION / RANGE - SIZE	FUNCTION
AT \ K3	Y	"Expedited" signaling regardless of its sequence in data sent and received; data integrity maintained	
AT \ K5*	Y	"In sequence" signaling as data is sent and received; data integrity maintained ahead of and after break	
AT \ K0,2,4	-	Not Supported (Will be equal to AT \ K5 if selected)	
AT \ Tn	Y	N = 0-90 min N* = 0 (disable)	Inactivity Timer
%D0*	Y	Hang up without clearing buffer	
%D1	Y	Clear the receive buffer before hang up	
AT \ I	-	Not Functional	Interface Protocol
AT \ J0*	Y	BPS Rate Adjust Disabled	Speed Conversion Control Disable
AT \ J1	Y	BPS Rate Adjust Enabled Adjustment	Modem Port Rate
AT \ S	Y	List Profiles	
AT \ G0*	Y	Disables Modem Port Flow Control	Set Modem Port
AT \ G1	Y	Sets Modem Port Flow Control to Xon / Xoff	Flow Control
AT \ X0*	Y	Does Not Pass Xon / Xoff to Remote Modem	Xon / Xoff Pass Through Control
AT \ X1	Y	Passes Xon / Xoff to Remote Modem	
AT \ Q0	Y	Disable Flow Control	Serial Port Flow Control
AT \ Q1	Y	Bidirectional Xon / Xoff Enabled	
AT \ Q2*	Y	Unidirectional Hardware Control by CTS	
AT \ Q3	Y	Bidirectional Hardware Control by RTS / CTS	
AT \ Q4	Y	Unidirectional Xon / Xoff Send Only	
AT \ Q5		Keep CTS off until connect unidirectional hardware flow control	
AT \ Q6		Keep CTS off until connect bidirectional hardware flow control	
AT % U	Y	Not Functional	Clear Serial Port Speed Serial Port
AT - P0*	Y	Ignores Parity for Special Characters	Check Parity
AT - P1	Y	Processes Special Characters Only if they have Correct Parity	

Note: * Denotes Default Condition

See Command
AT \ V1 Above

STANDARD RESULT CODES \ V0		MODIFIED RESULT CODES \ V1	
Verbose	Numeric	Verbose	Numeric
CONNECT	1		
CONNECT 1200	5	CONNECT 1200 / REL 4 or 5	22
CONNECT 2400	10	CONNECT 2400 / REL 4 or 5	23
CONNECT 4800	11		
CONNECT 9600	12	CONNECT 1200/V.42	22
CONNECT 19200	14	CONNECT 2400/V.42	23

3

XR-2442

S	REGISTER FUNCTION
S0	Number of Rings to Answer: Default = 0 (no answer)(stored)
S1	Ring Count: Stores Number of Rings: Resets After Every Call
S2	Escape Code Character: Default = 043 (ASCII for "+")
S3	Carriage return Character: Default = 013
S4	Line Feed Character: Default = 010
S5	Back Space Character: Default = 008
S6	Wait for Dial Tone: Default = 002 (seconds) (minimum setting)
S7	Wait for Carrier After Dial: Default = 030 (seconds)
S8	Duration of Delay for Comma: Default = 002 (seconds)
S9	Carrier Detect Response Time: Default = 0.6 (seconds)
S10	Loss of Carrier Response Time Default = 1.4 (seconds)
S11	Touch Tone Duration: Default = 095 (milliseconds)
S12	Escape Code Guard Time: Default = 1 (second)
S13	Reserved
S14	Bit Mapped Register: Stored in NVRAM (XL93C46)
	Bit 0 Reserved
	Bit 1 Echo
	Bit 2 Result Codes
	Bit 3 Numeric Result Codes
	Bit 4 Always 0
	Bit 5 Tone/Pulse Dialing
	Bit 6 Reserved
	Bit 7 Answer/Originate
S15	Reserved
S16	Test Register
	Bit 0 ALB
	Bit 1 Reserved
	Bit 2 Local Digital Loopback
	Bit 3 Remote Digital Loopback (Not Supported)
	Bit 4 Initiate Remote Test
	Bit 5 Initiate Remote Test With Self Test
	Bit 6 Analog Loopback With Self Test
	Bit 7 Reserved
S17	Reserved
S18	Test Time Stored in NVRAM (XL93C46) Default = 000 (seconds)
S19	Reserved
S20	Reserved
S21	Bit Mapped Register Stored in NVRAM (XL93C46) READ ONLY
	Bit 0 0 = RJ11 Jack
	Bit 1 Not Used
	Bit 2 CTS RTS Function
	Bit 3 DTR Function
	Bit 4 DTR Function
	<u>Bit 4</u> <u>Bit 3</u> <u>Function</u>
	0 0 DTR Always True Default
	0 1 DTR Off, Forces Command State
	1 0 DTR Off, Forces Modem Offline
	1 1 Modem Initializes With DTR OFF (ATZ)

REGISTER NUMBER	REGISTER FUNCTION																																																																											
S22	<p>Bit 5 EIA Carrier Status</p> <p>Bit 6</p> <p>Bit 7 Guard Tone Select</p> <table style="margin-left: 20px;"> <thead> <tr> <th>Bit 7</th> <th>Bit 6</th> <th>Function</th> </tr> </thead> <tbody> <tr> <td>0</td> <td>0</td> <td>No Guard Tone <u>Default</u></td> </tr> <tr> <td>0</td> <td>1</td> <td>550 Hz Guard Tone</td> </tr> <tr> <td>1</td> <td>0</td> <td>1800 Hz Guard Tone</td> </tr> <tr> <td>1</td> <td>1</td> <td>Reserved</td> </tr> </tbody> </table> <p>Option Bit - Mapped Register</p> <p>Bit 0 Determines Speaker Volume</p> <p>Bit 1</p> <table style="margin-left: 20px;"> <thead> <tr> <th>Bit 1</th> <th>Bit 0</th> <th>Speaker Volume</th> </tr> </thead> <tbody> <tr> <td>0</td> <td>0</td> <td>Low</td> </tr> <tr> <td>0</td> <td>1</td> <td>Low</td> </tr> <tr> <td>1</td> <td>0</td> <td>Medium <u>Default</u></td> </tr> <tr> <td>1</td> <td>1</td> <td>High</td> </tr> </tbody> </table> <p>Bit 2 Determines the Speaker Status</p> <p>Bit 3</p> <table style="margin-left: 20px;"> <thead> <tr> <th>Bit 3</th> <th>Bit 2</th> <th>Speaker Status</th> </tr> </thead> <tbody> <tr> <td>0</td> <td>0</td> <td>Always Off</td> </tr> <tr> <td>0</td> <td>1</td> <td>On Until Carrier is Detected <u>Default</u></td> </tr> <tr> <td>1</td> <td>0</td> <td>Always On</td> </tr> <tr> <td>1</td> <td>1</td> <td>As '01', Except Off for Dialing</td> </tr> </tbody> </table> <p>Bit 4, 5 and 6 Determine Response Messages</p> <table style="margin-left: 20px;"> <thead> <tr> <th>Bit 6</th> <th>Bit 5</th> <th>Bit 4</th> <th>Message</th> </tr> </thead> <tbody> <tr> <td>0</td> <td>0</td> <td>0</td> <td>Basic Message Set</td> </tr> <tr> <td>1</td> <td>0</td> <td>0</td> <td>Extended with Connect 1200 and Connect 2400</td> </tr> <tr> <td>1</td> <td>0</td> <td>1</td> <td>Extended with 'No Dial Tone'</td> </tr> <tr> <td>1</td> <td>1</td> <td>0</td> <td>Extended with 'Busy'</td> </tr> <tr> <td>1</td> <td>1</td> <td>1</td> <td>Extended with All Messages <u>Default</u></td> </tr> </tbody> </table> <p>Bit 7 Determines Off Hook/On Hook (Make/Break) Ratio for Pulse Dialing</p> <table style="margin-left: 20px;"> <thead> <tr> <th>Bit 7</th> <th>Ratio</th> </tr> </thead> <tbody> <tr> <td>0</td> <td>39/61 (USA and Canada) <u>Default</u></td> </tr> <tr> <td>1</td> <td>33/67 (UK and Hong Kong)</td> </tr> </tbody> </table>	Bit 7	Bit 6	Function	0	0	No Guard Tone <u>Default</u>	0	1	550 Hz Guard Tone	1	0	1800 Hz Guard Tone	1	1	Reserved	Bit 1	Bit 0	Speaker Volume	0	0	Low	0	1	Low	1	0	Medium <u>Default</u>	1	1	High	Bit 3	Bit 2	Speaker Status	0	0	Always Off	0	1	On Until Carrier is Detected <u>Default</u>	1	0	Always On	1	1	As '01', Except Off for Dialing	Bit 6	Bit 5	Bit 4	Message	0	0	0	Basic Message Set	1	0	0	Extended with Connect 1200 and Connect 2400	1	0	1	Extended with 'No Dial Tone'	1	1	0	Extended with 'Busy'	1	1	1	Extended with All Messages <u>Default</u>	Bit 7	Ratio	0	39/61 (USA and Canada) <u>Default</u>	1	33/67 (UK and Hong Kong)
Bit 7	Bit 6	Function																																																																										
0	0	No Guard Tone <u>Default</u>																																																																										
0	1	550 Hz Guard Tone																																																																										
1	0	1800 Hz Guard Tone																																																																										
1	1	Reserved																																																																										
Bit 1	Bit 0	Speaker Volume																																																																										
0	0	Low																																																																										
0	1	Low																																																																										
1	0	Medium <u>Default</u>																																																																										
1	1	High																																																																										
Bit 3	Bit 2	Speaker Status																																																																										
0	0	Always Off																																																																										
0	1	On Until Carrier is Detected <u>Default</u>																																																																										
1	0	Always On																																																																										
1	1	As '01', Except Off for Dialing																																																																										
Bit 6	Bit 5	Bit 4	Message																																																																									
0	0	0	Basic Message Set																																																																									
1	0	0	Extended with Connect 1200 and Connect 2400																																																																									
1	0	1	Extended with 'No Dial Tone'																																																																									
1	1	0	Extended with 'Busy'																																																																									
1	1	1	Extended with All Messages <u>Default</u>																																																																									
Bit 7	Ratio																																																																											
0	39/61 (USA and Canada) <u>Default</u>																																																																											
1	33/67 (UK and Hong Kong)																																																																											
S23	<p>Option Bit Mapped Register</p> <p>(LSB) Bit 0 Not Supported</p> <table style="margin-left: 20px;"> <thead> <tr> <th>Bit 3</th> <th>Bit 2</th> <th>Bit 1</th> <th></th> </tr> </thead> <tbody> <tr> <td>0</td> <td>0</td> <td>0</td> <td>300</td> </tr> <tr> <td>0</td> <td>0</td> <td>1</td> <td>Not Used</td> </tr> <tr> <td>0</td> <td>1</td> <td>0</td> <td>1200</td> </tr> <tr> <td>0</td> <td>1</td> <td>1</td> <td>2400</td> </tr> <tr> <td>1</td> <td>0</td> <td>0</td> <td>4800</td> </tr> <tr> <td>1</td> <td>0</td> <td>1</td> <td>9600</td> </tr> <tr> <td>1</td> <td>1</td> <td>0</td> <td>19200</td> </tr> <tr> <td>1</td> <td>1</td> <td>1</td> <td>38400(reserved)</td> </tr> </tbody> </table> <p>Bit 4 Determines the Parity for Transmitting and Receiving Data</p>	Bit 3	Bit 2	Bit 1		0	0	0	300	0	0	1	Not Used	0	1	0	1200	0	1	1	2400	1	0	0	4800	1	0	1	9600	1	1	0	19200	1	1	1	38400(reserved)																																							
Bit 3	Bit 2	Bit 1																																																																										
0	0	0	300																																																																									
0	0	1	Not Used																																																																									
0	1	0	1200																																																																									
0	1	1	2400																																																																									
1	0	0	4800																																																																									
1	0	1	9600																																																																									
1	1	0	19200																																																																									
1	1	1	38400(reserved)																																																																									

XR-2442

REGISTER NUMBER	REGISTER FUNCTION																																																																												
	<p>Bit 5</p> <table border="1"> <thead> <tr> <th>Bit 5</th> <th>Bit 4</th> <th>Parity</th> </tr> </thead> <tbody> <tr> <td>0</td> <td>0</td> <td>Even <u>Default</u></td> </tr> <tr> <td>0</td> <td>1</td> <td>Space/None</td> </tr> <tr> <td>1</td> <td>0</td> <td>Odd</td> </tr> <tr> <td>1</td> <td>1</td> <td>Mark</td> </tr> </tbody> </table> <p>Bit 6 Determines Guard Tone Frequency</p> <p>Bit 7 (Used in European Applications)</p> <table border="1"> <thead> <tr> <th>Bit 7</th> <th>Bit 6</th> <th>Guard Tone (Hz)</th> </tr> </thead> <tbody> <tr> <td>0</td> <td>0</td> <td>Disabled <u>Default</u></td> </tr> <tr> <td>0</td> <td>1</td> <td>550</td> </tr> <tr> <td>1</td> <td>0</td> <td>1800</td> </tr> <tr> <td>1</td> <td>1</td> <td>Reserved</td> </tr> </tbody> </table> <p>Not Used</p> <p>S24 Delay to DTR (Stored in NVRAM) Default = 005 (seconds)</p> <p>S25 RTS to CTS Delay (Synchronous Mode Only) Default = 1 (milliseconds)</p> <p>S26 Bit Mapped Register STORED IN NVRAM</p> <p>S27</p> <p>Bit 0</p> <p>Bit 1 Transmission Mode</p> <table border="1"> <thead> <tr> <th>Bit 1</th> <th>Bit 0</th> <th>Function</th> </tr> </thead> <tbody> <tr> <td>0</td> <td>0</td> <td>Asynchronous Mode <u>Default</u></td> </tr> <tr> <td>0</td> <td>1</td> <td>Synchronous Mode 1</td> </tr> <tr> <td>1</td> <td>0</td> <td>Synchronous Mode 2</td> </tr> <tr> <td>1</td> <td>1</td> <td>Synchronous Mode 3</td> </tr> </tbody> </table> <p>Bit 2 Reserved</p> <p>Bit 3 Reserved</p> <p>Bit 4</p> <p>Bit 5 Transmission Mode</p> <table border="1"> <thead> <tr> <th>Bit 5</th> <th>Bit 4</th> <th>Function</th> </tr> </thead> <tbody> <tr> <td>0</td> <td>0</td> <td>Internal Modem Clock Used <u>Default</u></td> </tr> <tr> <td>0</td> <td>1</td> <td>DTE Supplied Clock</td> </tr> <tr> <td>1</td> <td>0</td> <td>Slave Clock Mode</td> </tr> <tr> <td>1</td> <td>1</td> <td>Same as 00</td> </tr> </tbody> </table> <p>Bit 6 CCITT or Bell Handshaking Standard</p> <table border="1"> <tbody> <tr> <td>0</td> <td>CCITT</td> </tr> <tr> <td>1</td> <td>Bell (including CCITT V.22bis) <u>Default</u></td> </tr> </tbody> </table> <p>Bit 7 Reserved</p> <p>Reserved</p> <p>S28-35 Negotiate Failure Fallback (Affected by %C and \N)</p> <p>S36</p> <table border="1"> <thead> <tr> <th>Bits</th> <th>Function</th> </tr> </thead> <tbody> <tr> <td>0</td> <td>Hang Up</td> </tr> <tr> <td>1</td> <td>Attempt a standard asynchronous connection (&Q0)</td> </tr> <tr> <td>3</td> <td>Attempt an asynchronous connection using automatic speed buffering (&Q6)</td> </tr> <tr> <td>4</td> <td>Attempt a V.42 Alternative Protocol connection (MNP compatible); if negotiation fails, attempt a standard asynchronous connection</td> </tr> <tr> <td>5</td> <td>Attempt a V.42 Alternative Protocol connection (MNP compatible); if negotiation fails attempt a standard asynchronous connection</td> </tr> </tbody> </table> <p>S37 Not Supported</p>	Bit 5	Bit 4	Parity	0	0	Even <u>Default</u>	0	1	Space/None	1	0	Odd	1	1	Mark	Bit 7	Bit 6	Guard Tone (Hz)	0	0	Disabled <u>Default</u>	0	1	550	1	0	1800	1	1	Reserved	Bit 1	Bit 0	Function	0	0	Asynchronous Mode <u>Default</u>	0	1	Synchronous Mode 1	1	0	Synchronous Mode 2	1	1	Synchronous Mode 3	Bit 5	Bit 4	Function	0	0	Internal Modem Clock Used <u>Default</u>	0	1	DTE Supplied Clock	1	0	Slave Clock Mode	1	1	Same as 00	0	CCITT	1	Bell (including CCITT V.22bis) <u>Default</u>	Bits	Function	0	Hang Up	1	Attempt a standard asynchronous connection (&Q0)	3	Attempt an asynchronous connection using automatic speed buffering (&Q6)	4	Attempt a V.42 Alternative Protocol connection (MNP compatible); if negotiation fails, attempt a standard asynchronous connection	5	Attempt a V.42 Alternative Protocol connection (MNP compatible); if negotiation fails attempt a standard asynchronous connection
Bit 5	Bit 4	Parity																																																																											
0	0	Even <u>Default</u>																																																																											
0	1	Space/None																																																																											
1	0	Odd																																																																											
1	1	Mark																																																																											
Bit 7	Bit 6	Guard Tone (Hz)																																																																											
0	0	Disabled <u>Default</u>																																																																											
0	1	550																																																																											
1	0	1800																																																																											
1	1	Reserved																																																																											
Bit 1	Bit 0	Function																																																																											
0	0	Asynchronous Mode <u>Default</u>																																																																											
0	1	Synchronous Mode 1																																																																											
1	0	Synchronous Mode 2																																																																											
1	1	Synchronous Mode 3																																																																											
Bit 5	Bit 4	Function																																																																											
0	0	Internal Modem Clock Used <u>Default</u>																																																																											
0	1	DTE Supplied Clock																																																																											
1	0	Slave Clock Mode																																																																											
1	1	Same as 00																																																																											
0	CCITT																																																																												
1	Bell (including CCITT V.22bis) <u>Default</u>																																																																												
Bits	Function																																																																												
0	Hang Up																																																																												
1	Attempt a standard asynchronous connection (&Q0)																																																																												
3	Attempt an asynchronous connection using automatic speed buffering (&Q6)																																																																												
4	Attempt a V.42 Alternative Protocol connection (MNP compatible); if negotiation fails, attempt a standard asynchronous connection																																																																												
5	Attempt a V.42 Alternative Protocol connection (MNP compatible); if negotiation fails attempt a standard asynchronous connection																																																																												

REGISTER NUMBER	REGISTER FUNCTION
S38	Not Supported
S39	Reserved
S40	Not Supported
S41	Not Supported
S43-45	Reserved
S46	Protocol Selection: <u>Bits</u> 136 LAPM only (V.42)
S47	Not Supported
S48	Feature Negotiation Action 0 Negotiation disabled; presume the remote modem is configured for and has the capabilities necessary for the connection selected with S46 3 Negotiation enabled, but originating modem remains silent during detection phase. For connections with MNP modems; defeats negotiation sequence with other V.42 modems 7 Negotiation enabled 128 Negotiation disabled; forces fallback options specified in S36 to be taken immediately
S82	Break Handling: Affected by \K commands 3 "Expedited" signaling regardless of its sequence in data sent and received; data integrity maintained 7 "Destructive" signaling regardless of its sequence in data sent and received; data in process at time is destroyed 128 "In sequence" signaling as data is sent and received; data integrity maintained ahead of and after break
S86	Not Supported

Special Notes regarding the use of S registers above S27 and AT/n Commands.

- Changes of S register values above S27 will effect the profile display for AT/n Commands. AT/n Commands however, do not modify the setting of S registers.
- It is intended that a user or application software package will use only one method (S register \ n Commands) to effect the error control functions. Use of a combination could result in unpredictable behavior.

XR-2442

APPLICATIONS INFORMATION

The XR-2442 is shown in the XR-2400 modem schematic. The XR-2442 provides the command controller function for the XR-2400 V.22bis modem chip set, providing a high quality 2400 BPS modem. The modem operates error-free through LAPM or MNP 2-4 modes and can offer increased throughput with MNP 5. The XR-2321 device included adds CCITT V.21 and V.23 FSK modes, optional and can be eliminated for designs not requiring these modes.

Detailed information for the XR-2400 is available in XR-2400 V.22bis modem chip set datasheet. **Note** that the Analog Front End (AFE) used in this design is the XR-2402A. This device is an improved, pin-to-pin replacement for the XR-2402, details available in its own datasheet.

Layout Hints

In order for the XR-2442 to provide optimal support for best performance of the modem, some design hints/rules should be followed.

- Locate the XR-2402A AFE near the DAA section
 - provide for a short transmit / receive carrier input path, away from Bus/Digital lines.
- Maintain separate analog and digital grounds/power lines back to the power supply sources.
- Bypass (capacitor decouple) the XR-2401, XR-2402A, XR-2442 and op amp power supplies with both 0.01 μ F ceramic and 0.47 μ F tantalum capacitors near their actual pins. Ensure analog/digital supplies are bypassed to their respective ground.
- Crystal - parallel resonant type. Typical loading capacitors are 18pF.

SYSTEM PERFORMANCE

Performance for an error-correcting modem has two major areas.

1) DATA PUMP PERFORMANCE

With error-correction capabilities turned off, the integrity of the data pump to pass data in the presence of impairments. Most often the major specification measured here is the probability of data errors with the receive carrier impaired by noise, or BER (bit error rate) vs S/N (Signal-to-Noise ratio).

Figure 3 shows BER vs S/N for the circuit in the XR-2400 modem schematic, as measured with the test set-up in Figure 4.

2) ERROR CONTROLLER PERFORMANCE

The XR-2442, when in LAPM or MNP modes provides the control and correction required to yield perfect data transfer.

Beyond error correction, throughput, or data transfer rate, is another important parameter to the modems overall performance.

LAPM and MNP 2-4 Modes are not specifically provided for increased throughput. However an additional benefit of their error-correcting schemes is roughly a 20% increase in throughput. Using the 'Quick Brown Fox....' pattern, both LAPM and MNP 4 modes yielded better than a 20% throughput increase. V.22bis mode was used for this test, with an actual throughput of better than 2900 BPS measured.

MNP 5 Data Compression Included in the XR-2442 allows roughly a 100% throughput increase over the modems nominal data rate. As previously discussed, the throughput performance of MNP 5 varies with different types of data. (Figure 5 shows data for various data patterns). (Figure 6 illustrates the test set-up used for measuring the XR-2400 modem performance).

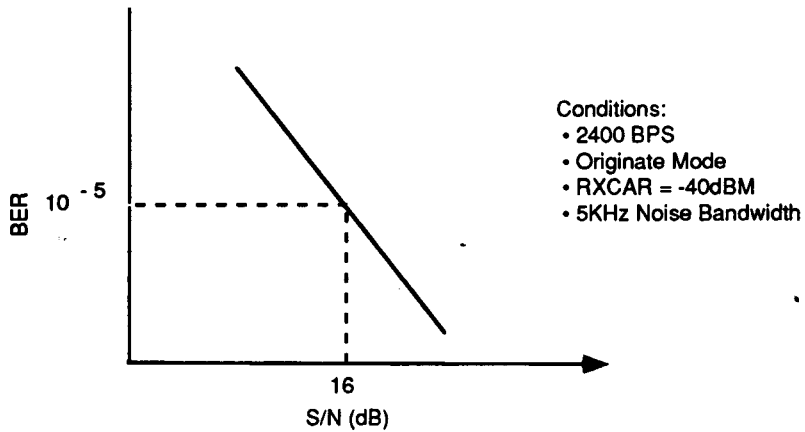

Figure 3. 2400 BPS Ber vs. S/N (Non-Error Correcting)

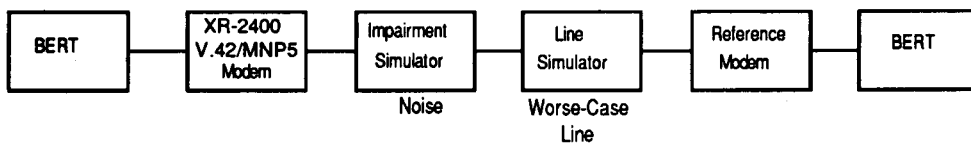

Figure 4. Data Quality Test Set-Up

XR-2442

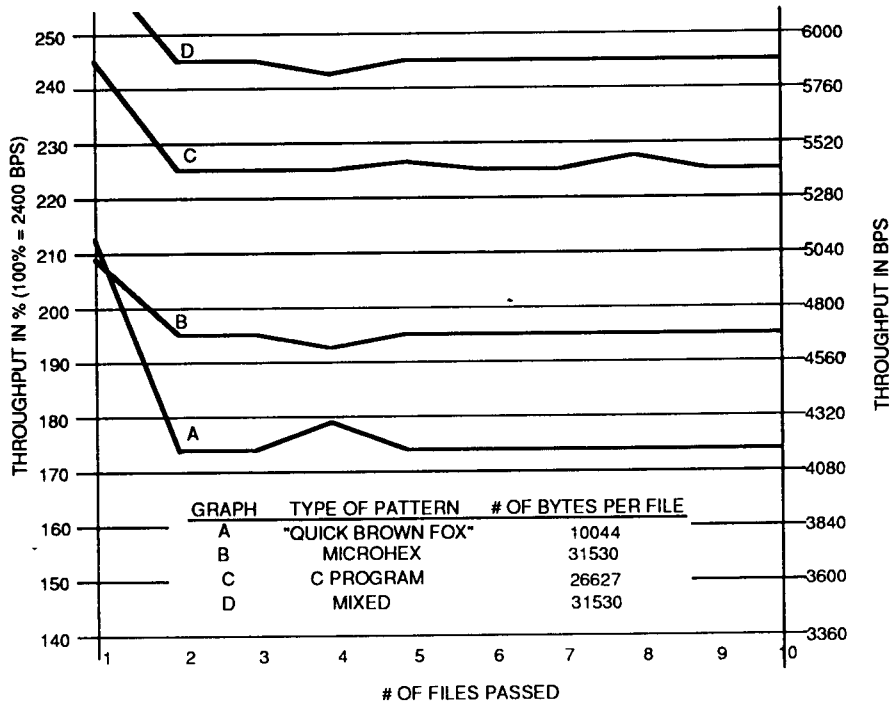
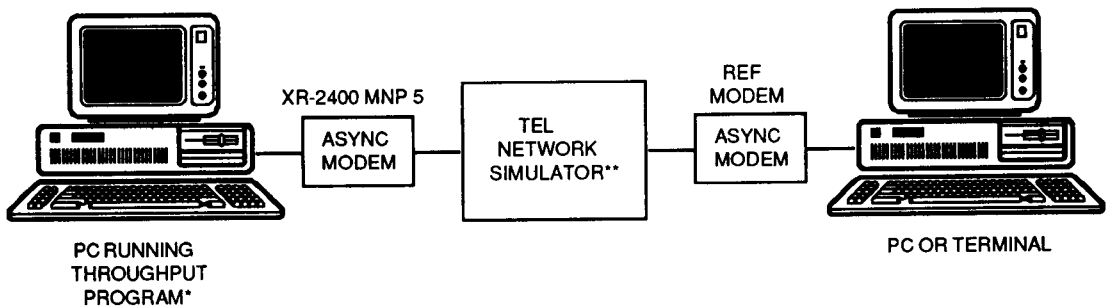

Figure 5. Effective Data Throughput



* APT (Asynchronous Performance Tester), also contains data or files to be used during measurement. Product of Concord Data Systems.

** Simulates line impairment and attenuation conditions.

Figure 6. MNP5 Throughput Measurement Test

