

Mixer, Image Reject  
14.4 — 19.7 GHz

M/A-COM Products  
Advanced: Rev. —

## Features

- 23 dBm Input IP3
- 8 dB Conversion Loss
- 30 dB Image Rejection
- +15 dBm LO Input
- 4 mm, 24 Lead QFN Package
- RoHS Compliant
- MSL 1

## Description

The MAMX-008879-PKG003 is an Image Reject Mixer that may be used for downconversion and upconversion. High IP3, excellent return losses, high isolation, and excellent image rejection make this mixer an ideal choice for point-to-point radio applications.

The RoHS compliant QFN package is compatible with 260°C reflow temperatures and has an MSL 1 rating. The MTTF is greater than 1,000,000 hours over the full operating temperature range of -40 to +85°C.

## Electrical Specifications: $Z_0 = 50\Omega$ , LO = +15 dBm

Parameter	Units	Typical
RF and LO Frequency	GHz	14.4-19.7
IF Frequency	GHz	DC-3.5
Conversion Loss	dB	8
Image Rejection	dB	30
LO to RF Isolation	dB	45
LO to IF Isolation	dB	25
RF Return Loss	dB	10
IF Return Loss	dB	15
Input IP3	dBm	23
Input P1dB	dBm	14
Amplitude Balance	dBm	0.2
Phase Balance	o	4

## Product Drawing

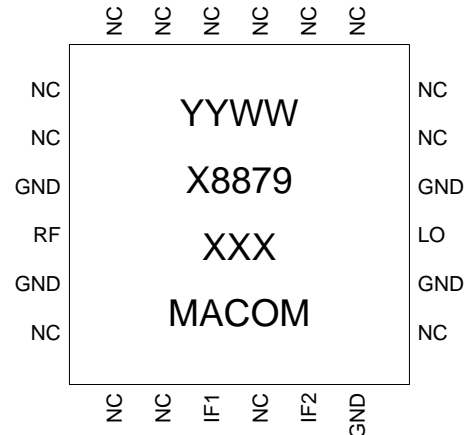

## Absolute Maximum Ratings

Parameter	Absolute Maximum
Storage Temperature	-55°C to +150°C
Case Temperature	-40°C to +85°C
Junction Temperature	+150°C
LO Input Power	+23 dBm
RF Input Power	+20 dBm
IF Input Power	+20 dBm
ESD Level (HBM)	250V

## Ordering Information

Part Number	Package
MAMX-008879-PKG003	4 mm, 24 Lead QFN
MAMX-008879-SMB003	Evaluation Sample Board
MAMX-008879-DIE000	Bare Die

## Outline Drawing

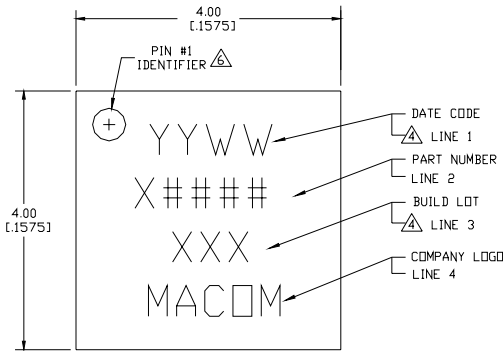

Dimensions are in mm (inches)

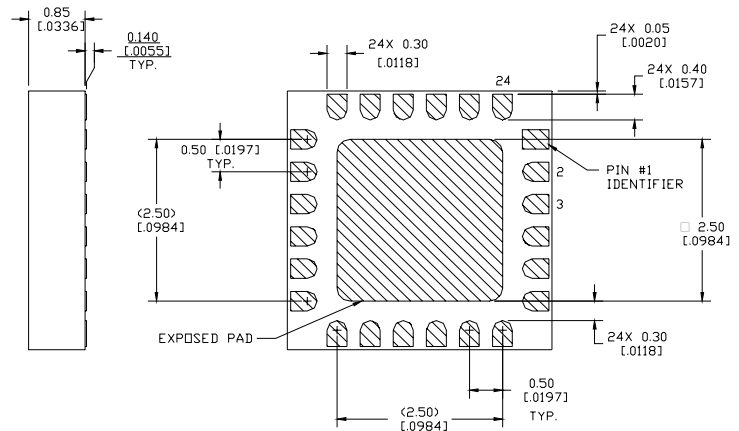

## Pin Designations

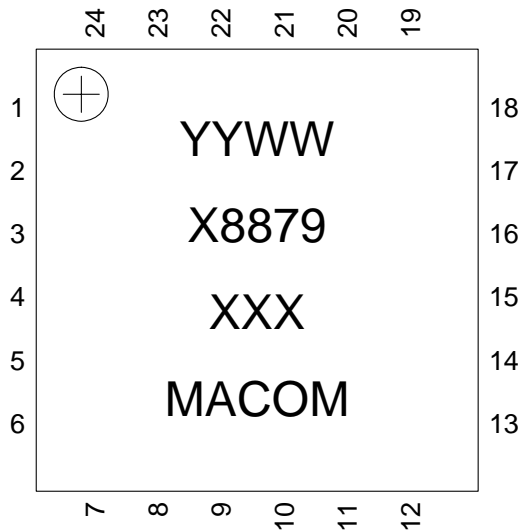

Pin	Function	Pin	Function
1	NC	13	NC
2	NC	14	GND
3	GND	15	LO
4	RF	16	GND
5	GND	17	NC
6	NC	18	NC
7	NC	19	NC
8	NC	20	NC
9	IF1	21	NC
10	NC	22	NC
11	IF2	23	NC
12	GND	24	NC

Exposed pad on bottom is ground