

QP SERIES

Miniature DC/DC Converters
5 to 500Vdc, Isolated, 50 Watt Regulated Outputs
Wide Inpt Voltage Ranges
4.9 - 9 Vdc / 9 - 18 Vdc / 18 - 36 Vdc / 36 - 72 Vdc (NEW)

NEW

Wide Input Range	
6QP	4.5 - 9 Vdc
12QP	9 - 18 Vdc
24QP	18 - 36 Vdc
48QP	36 - 72 Vdc
Consult Factory for Special Input	

Isolated, Regulated Outputs
High Efficiency, Low Ripple
0°C to +85°C Operating Temperature, Base Plate
Miniature - Low Profile (2.5" x 1.55" x 0.5") - PCB Mountable
High Reliability DC-DC Converters

The **QP Series** of Miniature Power DC/DC Converters operates over wide input voltage ranges (**4.5-9Vdc, 9-18Vdc, 18 - 36 Vdc, and 36 - 72 Vdc**) while maintaining tight output regulation and low ripple.

Safety Features of **QP Modules** include: Overtemperature, Input Under/Over voltage, Output Overcurrent and Short Circuit Protection.

Units in **QP Series** also feature Remote Shutdown, Trim capability, 3Vref, External Bias and do not use OptoCouplers in the feed-back loop.

Fixed Frequency operation enables parallel connection for higher power requirements.

QP Series units are fully encapsulated for rugged operation.

APPLICATIONS:

Commercial, industrial and Military applications, process control, distributed power, test equipment, telecommunications.

FEATURES:

- Input Voltage Ranges: 4.5 - 9 Vdc, 9-18Vdc, 18-36Vdc., and 36 - 72 Vdc. For additional input voltages consult factory.
- Output Voltage: 5Vdc to 500Vdc. 11 standard voltages, custom output voltages are also available.
- Line and Load Regulation: from 0.5% Vout
- Efficiency: Up to 90%
- Low Ripple
- Input Under/Over Voltage Protection
- Output Overcurrent and Short Circuit Protection
- Output Voltage Clamp: typ. 120% Vout
- Thermal Shutdown
- Trim Capability: - 5% Vout
- 3Vref output pin
- Remote Shutdown
- External Bias pin for capacitor charging applications
- 0°C to +85°C standard operating base plate temperature. Expanded operating temperature also available
- 2500 Vrms In/Out Isolation
- Fully Encapsulated

6QP SERIES

25W, SINGLE OUTPUT, 4.5 - 9Vin

PICO MODEL	INPUT VOLTAGE RANGE (V)	OUTPUT VOLTAGE (V)	OUTPUT POWER MAX. (W)**	EFF. (TYP.) @ FL (%)	REGULATION (MAX)		OUTPUT VOLTAGE RIPPLE Pk-Pk, @FL (mVpp)	OUTPUT VOLTAGE SETUP TOL. (%)	PRICE (US \$)
					LINE 4.5-9Vin (%)	LOAD*** 10-100% FL (%)			
6QP5.0	4.5 - 9	5	20	73	4	2	50	0.5	170.28
6QP12	4.5 - 9	12	20	82	2	1.5	40	0.5	170.28
6QP15	4.5 - 9	15	25	82	2	1.5	40	0.5	170.28
6QP24	4.5 - 9	24	25	81	1.5	1	20	0.5	170.28
6QP28	4.5 - 9	28	25	81	1.5	1	20	0.5	182.53
6QP48	4.5 - 9	48	25	80	2	1.5	30	0.5	194.78
6QP100	4.5 - 9	100	25	82	3	2	20	0.5	238.88
6QP200	4.5 - 9	200	25	77	3	2	150	0.5	300.14
6QP300*	4.5 - 9	300	20	80	2.5	2	100	0.5	361.39
6QP400*	4.5 - 9	400	20	79	2.5	2	200	0.5	398.14
6QP500*	4.5 - 9	500	20	76	2	1.5	200	0.5	428.77

* For these units, Pout max is linearly derated at 7.5W/V for input voltages lower than 5.5V

**Proper thermal management required: Base Plate Temp. <85°C (See Application Notes)

***10% minimum load required at any time

12QP SERIES

50W, SINGLE OUTPUT, 9-18Vin

PICO MODEL	INPUT VOLTAGE RANGE (V)	OUTPUT VOLTAGE (V)	OUTPUT POWER MAX. (W)**	EFF. (TYP.) @ FL (%)	REGULATION (MAX)		OUTPUT VOLTAGE RIPPLE Pk-Pk, @FL (mVpp)	OUTPUT VOLTAGE SETUP TOL. (%)	PRICE (US \$)
					LINE 9-18Vin (%)	LOAD*** 10-100% FL (%)			
12QP5.0	9-18	5	40	78	3	3	50	0.5	170.28
12QP12	9-18	12	40	85	1.5	2	40	0.5	170.28
12QP15	9-18	15	50	85	1.5	2	40	0.5	170.28
12QP24	9-18	24	50	85	1	1.5	20	0.5	170.28
12QP28	9-18	28	50	85	1	1.5	20	0.5	182.53
12QP48	9-18	48	50	85	1	1.5	30	0.5	194.78
12QP100	9-18	100	50	86	1	1.5	20	0.5	238.88
12QP200	9-18	200	50	85	1.5	2	150	0.5	300.14
12QP300*	9-18	300	40	87	1	1	100	0.5	361.39
12QP400*	9-18	400	40	87	1	1	200	0.5	398.14
12QP500*	9-18	500	40	86	1	1	200	0.5	428.77

* For these units, Pout max is linearly derated at 6.7 W/V for input voltages lower than 10.5V

**Proper thermal management required: Base Plate Temp. <85°C (See Application Notes)

***10% minimum load required at any time

24QP SERIES

50W, SINGLE OUTPUT, 18-36Vin

PICO MODEL	INPUT VOLTAGE RANGE (V)	OUTPUT VOLTAGE (V)	OUTPUT POWER MAX. (W)**	EFF. (TYP.) @ FL (%)	REGULATION (MAX)		OUTPUT VOLTAGE RIPPLE Pk-Pk, @FL (mVpp)	OUTPUT VOLTAGE SETUP TOL. (%)	PRICE (US \$)
					LINE 18-36Vin (%)	LOAD*** 10-100% FL (%)			
24QP5.0	18-36	5	40	79	3	2	50	0.5	170.28
24QP12	18-36	12	40	88	1	1.5	40	0.5	170.28
24QP15	18-36	15	50	88	1	1.5	40	0.5	170.28
24QP24	18-36	24	50	87	1	1	20	0.5	170.28
24QP28	18-36	28	50	87	1	1	20	0.5	182.53
24QP48	18-36	48	50	87	1	1	30	0.5	194.78
24QP100	18-36	100	50	88	1	1	20	0.5	238.88
24QP200	18-36	200	50	87	1	1.5	150	0.5	300.14
24QP300*	18-36	300	40	90	0.5	1	100	0.5	361.39
24QP400*	18-36	400	40	89	0.5	0.5	200	0.5	398.14
24QP500*	18-36	500	40	89	1	1	200	0.5	428.77

* For these units, **Proper thermal management required: Base Plate Temp. <85°C (See Application Notes)

***10% minimum load required at any time

48QP SERIES

50W, SINGLE OUTPUT, 36 - 72 Vin

PICO MODEL	INPUT VOLTAGE RANGE (V)	OUTPUT VOLTAGE (V)	OUTPUT POWER MAX. (W)**	EFF. (TYP.) @ FL (%)	REGULATION (MAX)		OUTPUT VOLTAGE RIPPLE Pk-Pk, @FL (mVpp)	OUTPUT VOLTAGE SETUP TOL. (%)	PRICE (US \$)
					LINE 36-72Vin (%)	LOAD*** 10-100% FL (%)			
48QP5.0	36-72	5	40	81	2	2	30	0.5	170.28
48QP12	36-72	12	50	83	1	1	20	0.5	170.28
48QP15	36-72	15	50	84	1	1	30	0.5	170.28
48QP24	36-72	24	50	88	1	1	20	0.5	170.28
48QP28	36-72	28	50	88	1	1	20	0.5	182.53
48QP48	36-72	48	50	89	1	1	30	0.5	194.78
48QP100	36-72	100	50	89	1	1	50	0.5	238.88
48QP200	36-72	200	50	89	1	1.5	250	0.5	300.14
48QP300	36-72	300	40	90	0.5	1	200	0.5	361.39
48QP400	36-72	400	40	87	0.5	1	200	0.5	398.14
48QP500	36-72	500	40	89	1	1.5	200	0.5	428.77

** Proper thermal management required, Base Plate Temp <85° C (See Application Notes)
 *** 10% minimum load required at any time

ELECTRICAL CHARACTERISTICS:

Input OV/UV Protection

	6QP Series	12QP Series	24QP Series	48QP Series
UV SHDN	3.6	7.1 V	14.6 V	31.2V
UV RESTART	4.25	7.6 V	15.6 V	31.8V
OV SHDN	11	20 V	41 V	82V
OV RESTART	10.8	19.5 V	40 V	81.5V

Converter Frequency: 150 kHz typical
 Reference Voltage: 3Vdc +/-0.2V, 10mA max.
 Current Limit Protection: Hiccup Mode
 Output Voltage Clamp: 120% Vout typical
 Output Trimming Range: - 5% max.

	Rtrim connected between	Rtrim (kohm) calculation for a specified Δ Vout (%)
TRIM DOWN	TRIM (Pin #4) and VREF (Pin #3)	$(425 / \Delta V_{out}) - 51$

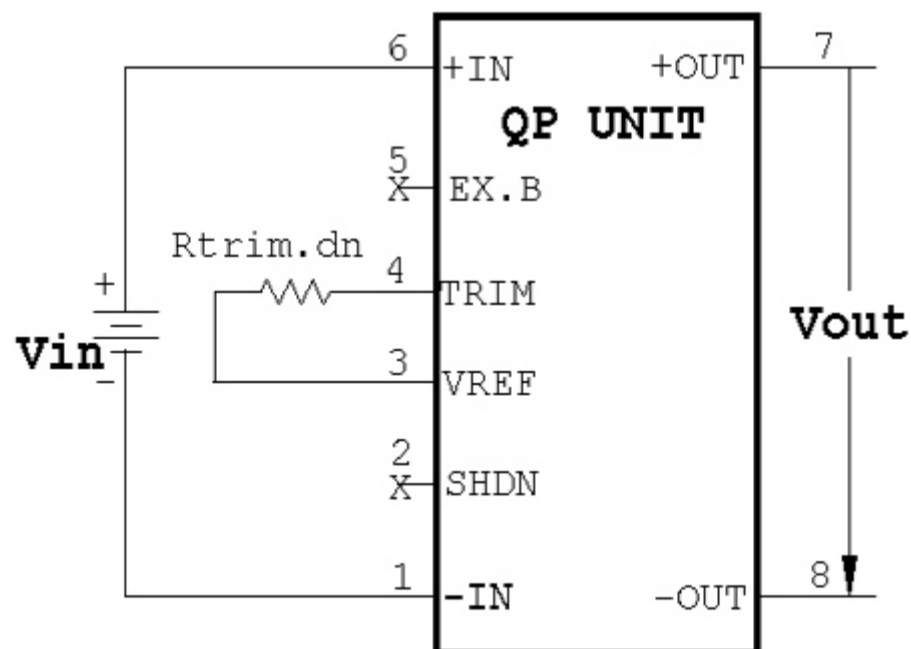

FIG. 1: Trim Down Connection
 For Trim Up Connection: Consult Factory

Δ Vout (%)	Rtrim (kohm)			
	1	2	3	5
TRIM DN	374	162	91	33

FIG. 2 Trim Down typical resistor values

For Trim Up: Consult Factory 800-431-1064

Remote Shutdown: Converter is turned off when Pin # 2 (SHDN) is clamped to Pin # 1 within less than 0.4 V

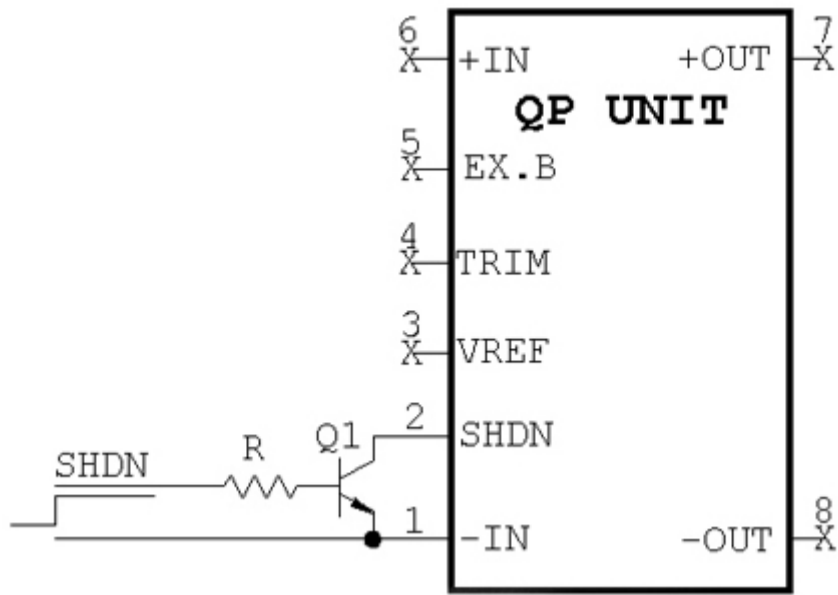

FIG. 3 Non Isolated Shutdown

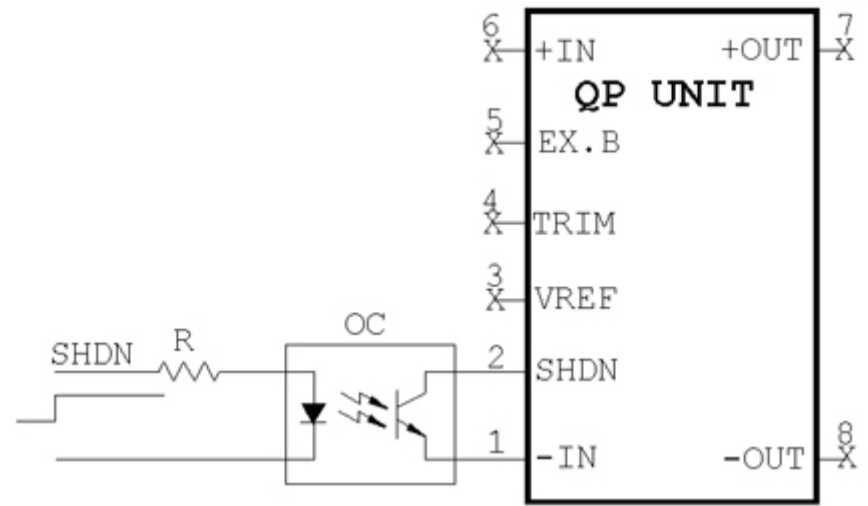

Fig. 4 Isolated Shutdown

External Bias Function

Ex.B Voltage = 17...20Vdc; Ex.B Current = 20mA (typical)

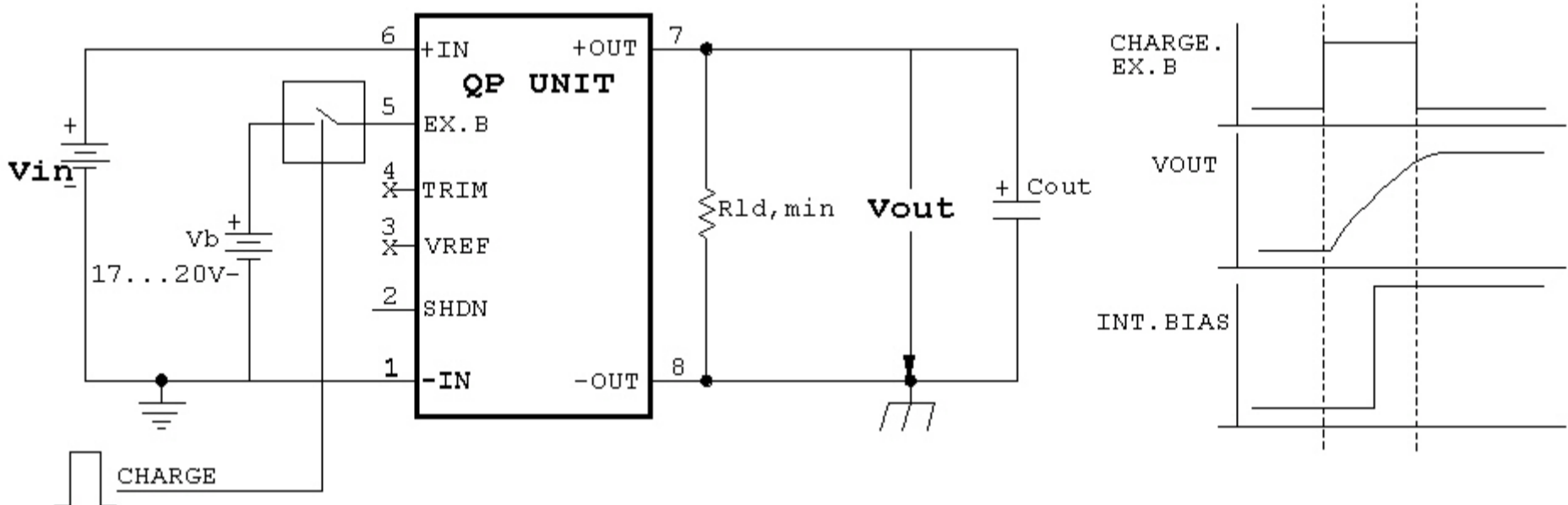

FIG.5 External Bias Operation; Schematic and Timing Diagram

External Bias should be used in Capacitor Charging applications. The QP unit will not start-up under a short-circuit condition because the Internal Bias Supply cannot develop the required start-up voltage. To charge up a large capacitor, an external bias voltage should be used only until the output voltage, V_{out} , reached 90 - 95% of its nominal value and therefore the internal bias voltage has come up and is able to sustain converter operation.

Note that during External Bias operation, output overload and short circuit protection are disabled and for this reason it is highly recommended - as shown in diagram - to disable the External Bias supply after V_{out} reaches its nominal value and allow from that moment on for the internal bias voltage operation. While on internal bias operation, overload and short circuit protections are restored.

For additional information, see Application Notes.

**Base Plate Over Temperature Shutdown: 95+/-5°C, non-latching
Isolation Characteristics:**

INPUT TO OUTPUT	4242 VDC
INPUT TO BASE PLATE	2121 VDC
OUTPUT TO BASE PLATE	1000 VDC

Operating Temperature Range (Base Plate): -0°C to + 85 °C

Storage Temperature Range: -55°C to + 125°C

PHYSICAL CHARACTERISTICS:

1000LFM	2.2	1.3
---------	-----	-----

QCH HEATSINK

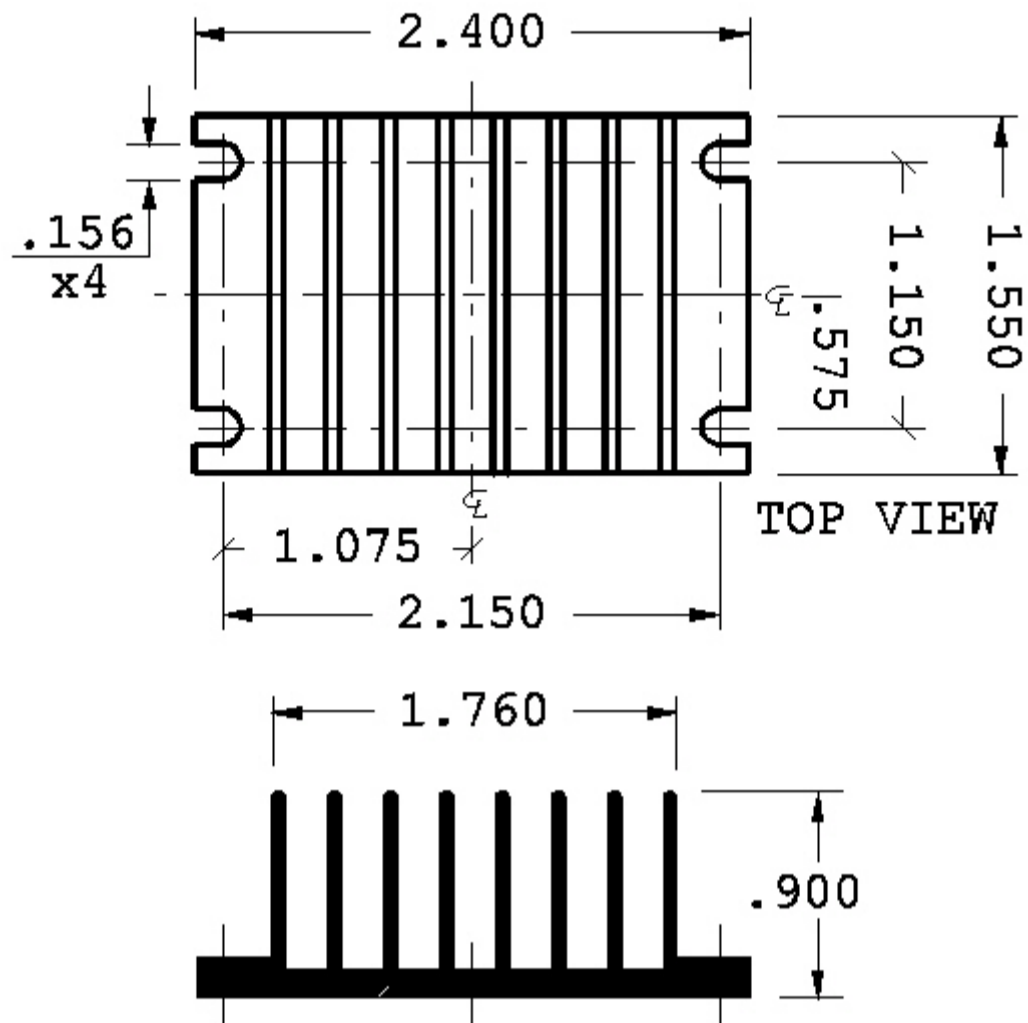

QTI THERMAL INTERFACE

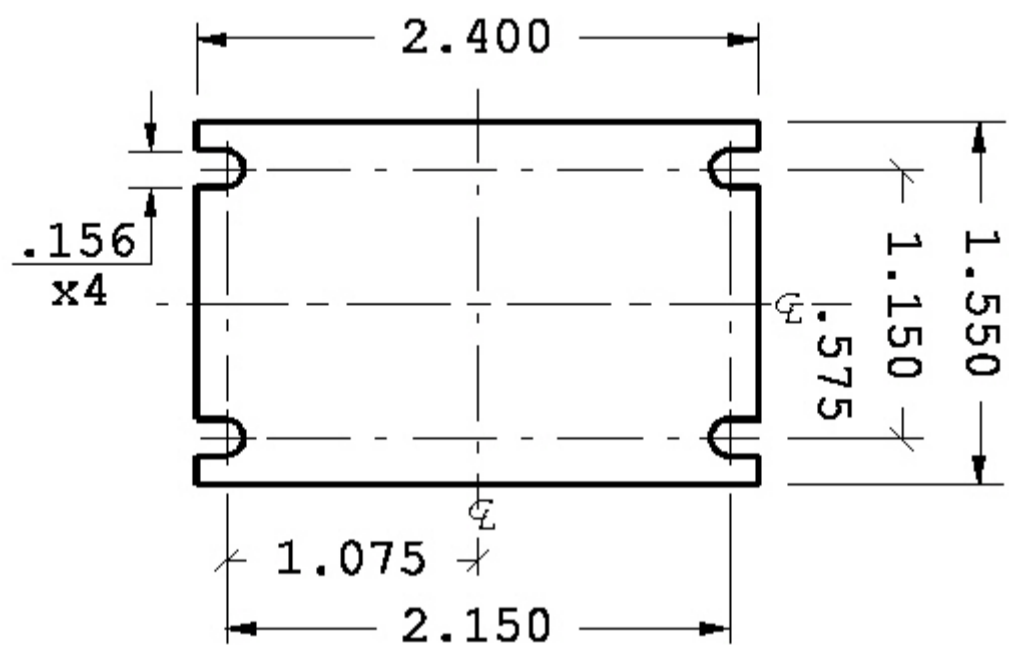

TYPE QCH	\$11.50
TYPE QTI	\$3.45
NOTE: For additional Heatsink options consult factory.	

PART TI = THERMAL INTERFACE
 Alloy Aluminum Substrate
 Thermal Conductivity (BTU-in/hr sq.ft. ° F): 1530
 Coefficient of Thermal Expansion (25-100°C, 10 {to the -6th} in-in/°F): 13.1

Hardness, Brinnell B: 23
Endurance Limit, psi: 5000
Standard Thickness (inches): .002

For immediate engineering assistance or to place an order:

Call Toll Free: 800-431-1064

PICO Electronics, Inc.

143 Sparks Ave. Pelham, NY 10803
Tel: 914-738-1400 or Fax: 914-738-8225
