

AN8882SB

Head amplifier IC for CD-ROM drive (for 32 times speed or more)

■ Overview

The AN8882SB is a head amplifier IC for digital servo. It can configure an efficient CD-ROM system in combination with the MN662754, and allows a full-automatic adjustment of tracking balance-gain-offset and focus balance-gain-offset with fewer external parts.

Built-in functions are a variable equalizer, wide band RF amp. and AGC which meet CAV playback with 32 times speed or more.

■ Features

- Variable equalizer which meets CAV playback with 32 times speed or more.
(6-step changeover)
- Wide band RF amp. and AGC ($f_c = 30$ MHz or more (-3 dB))
- Balance adjustment function built-in
Focus error amp./tracking error amp.
- CD-RW playback compatible.
Variable gain
Focus error amp./tracking error amp.
(to $+12$ dB)
- OFTR/BDO detection
- APC amp. (LD reference voltage changeover for CD-RW playback)

■ Applications

- CD/CD-ROM drive

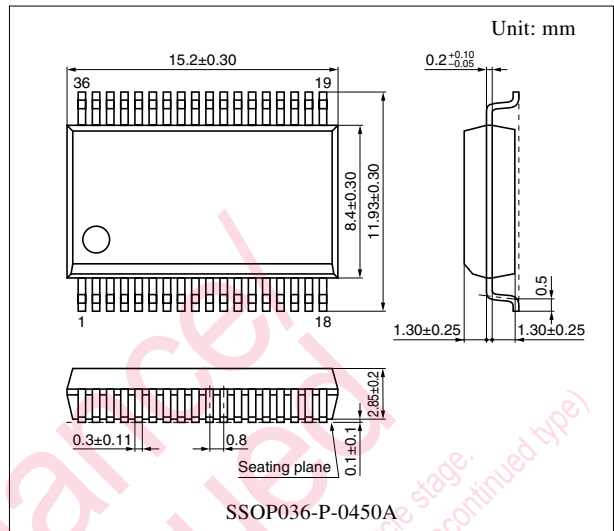

Note) The package of this product will be changed to lead-free type (SSOP036-P-0450C). See the new package dimensions section later of this datasheet.

■ Block Diagram

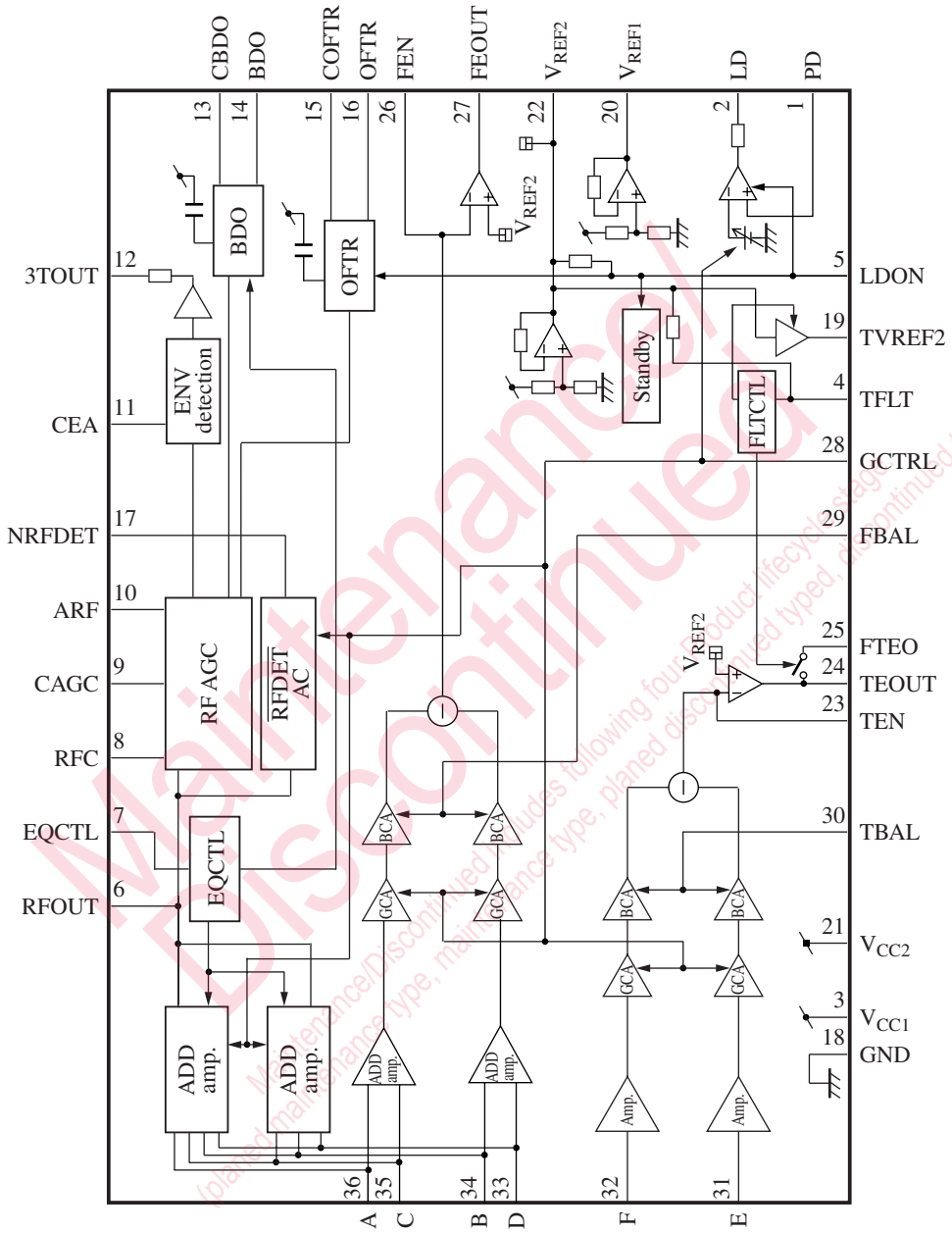

■ Pin Descriptions

Pin No.	Description	Pin No.	Description
1	APC amp. input pin	18	GND pin
2	APC amp. output pin	19	V _{REF2} buffer output pin
3	Power supply pin 1	20	V _{REF1} output pin
4	TE amp. analog SW & V _{REF2} buffer control pin	21	Power supply pin 2
		22	V _{REF2} output pin
5	APC & standby control pin	23	TE amp. inverted input pin
6	RF addition amp. output pin	24	TE amp. output pin
7	EQ characteristics control pin	25	TE amp. analog SW output pin
8	Capacitor connection pin for HPF of AGC input	26	FE amp. inverted input pin
9	AGC loop filter connection pin	27	FE amp. output pin
10	AGC output pin	28	GCTL pin
11	Capacitor connection pin for HPF amp.	29	FBAL control pin
12	3TENV output pin	30	TBAL control pin
13	Capacitor connection pin for RF dark-side envelope detection	31	Tracking signal input pin 1
		32	Tracking signal input pin 2
14	BDO output pin	33	Focus signal input pin 4
15	Capacitor connection pin for RF right-side envelope detection	34	Focus signal input pin 2
		35	Focus signal input pin 3
16	OFTR output pin	36	Focus signal input pin 1
17	NRFDDET output pin		

■ Absolute Maximum Ratings

Parameter	Symbol	Rating	Unit
Supply voltage 1	V _{CC1}	5.8	V
Supply voltage 2	V _{CC2}	5.8	V
Supply current 1	I _{CC1}	55.3	mA
Supply current 2	I _{CC2}	3.4	mA
Power dissipation	P _D	340.46	mW
Operating ambient temperature	T _{opr}	-20 to +75	°C
Storage temperature	T _{stg}	-55 to +125	°C

Note) Except for the power dissipation, operating ambient temperature and storage temperature, all ratings are for T_a = 25°C.

■ Recommended Operating Range

Parameter	Symbol	Range	Unit
Supply voltage 1	V _{CC1}	4.5 to 5.5	V
Supply voltage 2	V _{CC2}	3.0 to 5.5	V

■ Electrical Characteristics at $T_a = 25^\circ\text{C}$

Parameter	Symbol	Conditions	Min	Typ	Max	Unit
Current consumption with no load 1	I_{TOTAL1}	$V_{\text{CC1}} = 5\text{ V}$, $V_{\text{CC2}} = 3.3\text{ V}$ $V_{\text{EQCTL}} = V_{\text{REF2}} - 0.3\text{ V}$	28.1	40.1	52.1	mA
Current consumption with no load 2	I_{TOTAL2}	$V_{\text{CC1}} = 5\text{ V}$, $V_{\text{CC2}} = 3.3\text{ V}$ $V_{\text{EQCTL}} = V_{\text{REF2}} - 0.3\text{ V}$	1.80	2.57	3.34	mA
V_{REF1} output voltage	V_{REF1}	$V_{\text{CC1}} = 5\text{ V}$, $V_{\text{CC2}} = 3.3\text{ V}$	2.27	2.50	2.73	V
V_{REF2} output voltage	V_{REF2}	$V_{\text{CC1}} = 5\text{ V}$, $V_{\text{CC2}} = 3.3\text{ V}$	1.50	1.65	1.80	V
Focus error amp.						
Focus error amp. output offset voltage	$V_{\text{FO-OF}}$	$V_{\text{CC1}} = 5\text{ V}$, $V_{\text{CC2}} = 3.3\text{ V}$	-90	0	90	mV
Focus error amp. V-V conversion gain	G_{FO}	$V_{\text{CC1}} = 5\text{ V}$, $V_{\text{CC2}} = 3.3\text{ V}$ $V_{\text{GC}} = V_{\text{REF2}} - 0.3\text{ V}$	14.3	16.4	18.5	dB
Focus error amp. balance output 1	$B_{\text{FO1-H}}$	$V_{\text{CC1}} = 5\text{ V}$, $V_{\text{CC2}} = 3.3\text{ V}$ $V_{\text{FB}} = V_{\text{REF2}} + 0.5\text{ V}$	11.3	13.4	15.5	dB
Focus error amp. balance relative output 2	B_{FOH}	$V_{\text{CC1}} = 5\text{ V}$, $V_{\text{CC2}} = 3.3\text{ V}$ $V_{\text{FB}} = V_{\text{REF2}} - 0.5\text{ V}$	-3.0	0	3.0	dB
Focus error amp. frequency characteristics	G_{FOF}	$V_{\text{CC1}} = 5\text{ V}$, $V_{\text{CC2}} = 3.3\text{ V}$ $f = 3\text{ kHz}$, 60 kHz	-4.5	-3.0	-1.5	dB
Focus error amp. GCTRL gain ratio	B_{FO4}	$V_{\text{CC1}} = 5\text{ V}$, $V_{\text{CC2}} = 3.3\text{ V}$ $V_{\text{GC}} = V_{\text{REF2}} + 0.3\text{ V}$	3.0	4.0	5.0	—
Tracking error amp.						
Tracking error amp. output offset voltage	$V_{\text{TR-OF}}$	$V_{\text{CC1}} = 5\text{ V}$, $V_{\text{CC2}} = 3.3\text{ V}$	-70	0	70	mV
Tracking error amp. V-V conversion gain	G_{TR}	$V_{\text{CC1}} = 5\text{ V}$, $V_{\text{CC2}} = 3.3\text{ V}$ $V_{\text{GC}} = V_{\text{REF2}} - 0.3\text{ V}$	14.5	16.6	18.7	dB
Tracking error amp. balance output 1	$B_{\text{TR1-H}}$	$V_{\text{CC1}} = 5\text{ V}$, $V_{\text{CC2}} = 3.3\text{ V}$ $V_{\text{TB}} = V_{\text{REF2}} + 0.5\text{ V}$	11.3	13.4	15.5	—
Tracking error amp. balance relative output 2	B_{TRH}	$V_{\text{CC1}} = 5\text{ V}$, $V_{\text{CC2}} = 3.3\text{ V}$ $V_{\text{TB}} = V_{\text{REF2}} - 0.5\text{ V}$	-3.0	0	3.0	dB
Tracking error amp. frequency characteristics	G_{TRF}	$V_{\text{CC1}} = 5\text{ V}$, $V_{\text{CC2}} = 3.3\text{ V}$ $f = 30\text{ kHz}$, 510 kHz	-5.1	—	-0.6	dB
Tracking error amp. GCTRL gain ratio	B_{TR4}	$V_{\text{CC1}} = 5\text{ V}$, $V_{\text{CC2}} = 3.3\text{ V}$ $V_{\text{GC}} = V_{\text{REF2}} + 0.3\text{ V}$	3.0	4.0	5.0	—
RF addition amp.						
RF addition amp. full-addition gain 1	G_{RADA1}	$V_{\text{CC1}} = 5\text{ V}$, $V_{\text{CC2}} = 3.3\text{ V}$ $V_{\text{EQCTL}} = V_{\text{REF2}} - 0.5\text{ V}$	10.5	12.0	13.5	dB
RF addition amp. full-addition gain 2	G_{RADA2}	$V_{\text{CC1}} = 5\text{ V}$, $V_{\text{CC2}} = 3.3\text{ V}$ $V_{\text{EQCTL}} = V_{\text{REF2}} - 0.3\text{ V}$	10.5	12.0	13.5	dB

■ Electrical Characteristics at $T_a = 25^\circ\text{C}$ (continue)

Parameter	Symbol	Conditions	Min	Typ	Max	Unit
Variable EQ characteristics						
EQ characteristics 1 *	G_{EQ1}	$f = 10 \text{ kHz}, 720 \text{ kHz}$ $V_{EQCTL} = V_{REF2} - 0.5 \text{ V}$	-0.8	1.2	3.2	dB
EQ characteristics 2 *	G_{EQ2}	$f = 6.5 \text{ MHz}$ $V_{EQCTL} = V_{REF2} - 0.3 \text{ V}$	2.7	4.7	6.7	dB
EQ characteristics 3 *	G_{EQ3}	$f = 6.5 \text{ MHz}, V_{EQCTL} = V_{REF2} - 0.1 \text{ V}$	0.9	2.9	4.9	dB
EQ characteristics 4 *	G_{EQ4}	$f = 6.5 \text{ MHz}, V_{EQCTL} = V_{REF2} + 0.1 \text{ V}$	-0.1	1.9	3.9	dB
EQ characteristics 5 *	G_{EQ5}	$f = 6.5 \text{ MHz}, V_{EQCTL} = V_{REF2} + 0.3 \text{ V}$	-0.7	1.3	3.3	dB
EQ characteristics 6 *	G_{EQ6}	$f = 23 \text{ MHz}, V_{EQCTL} = V_{REF2} + 0.5 \text{ V}$	2.2	4.2	6.2	dB
AGC						
AGC max. gain	G_{MAGC}	$f = 500 \text{ kHz}, V_{IN} = 20 \text{ mV[p-p]}$	17.0	20.0	23.0	dB
AGC operating gain	G_{AGC}	$f = 500 \text{ kHz}, V_{IN} = 500 \text{ mV[p-p]}$	3.0	6.0	9.0	dB
NRFDET						
NRFDET detection level	V_{RDA1}	$f = 500 \text{ kHz}, V_{GC} = V_{REF2} - 0.3 \text{ V}$	65	105	145	mV[p-p]
NRFDET high-level output voltage	V_{RDAH}	$f = 500 \text{ kHz}, V_{GC} = V_{REF2} - 0.3 \text{ V}$	4.2	—	—	V
NRFDET low-level output voltage	V_{RDAL}	$f = 500 \text{ kHz}, V_{GC} = V_{REF2} - 0.3 \text{ V}$	—	—	0.8	V
BDO						
CBDO detection current	I_{CBDO}	$V_{CC1} = 5 \text{ V}, V_{CC2} = 3.3 \text{ V}$ $V_{EQCTL} = V_{REF2} - 0.5 \text{ V}$	0.48	0.78	1.08	μA
CBDO detection current ratio	B_{IBD10}	$V_{CC1} = 5 \text{ V}, V_{CC2} = 3.3 \text{ V}$ $V_{EQCTL} = V_{REF2} + 0.5 \text{ V}$	8.7	9.7	10.7	—
BDO high-level output voltage	V_{BDOH}	$V_{CC1} = 5 \text{ V}, V_{CC2} = 3.3 \text{ V}$ $f = 5 \text{ kHz}, \text{rectangular wave}$	2.5	—	—	V
BDO low-level output voltage	V_{BDOL}	$V_{CC1} = 5 \text{ V}, V_{CC2} = 3.3 \text{ V}$ $f = 5 \text{ kHz}, \text{rectangular wave}$	—	—	0.8	V
OFTR						
COFTR detection current	I_{COFTR}	$V_{CC1} = 5 \text{ V}, V_{CC2} = 3.3 \text{ V}$ $V_{LDON} = V_{REF2}$	0.48	0.78	1.08	μA
COFTR detection current ratio	B_{COFTR}	$V_{CC1} = 5 \text{ V}, V_{CC2} = 3.3 \text{ V}$ $V_{LDON} = V_{REF2} + 0.75 \text{ V}$	3.1	3.9	4.7	—
OFTR high-level output voltage	V_{OFTRH}	$V_{CC1} = 5 \text{ V}, V_{CC2} = 3.3 \text{ V}$ $f = 5 \text{ kHz}, \text{rectangular wave}$	2.5	—	—	V
OFTR low-level output voltage	V_{OFTRL}	$V_{CC1} = 5 \text{ V}, V_{CC2} = 3.3 \text{ V}$ $f = 5 \text{ kHz}, \text{rectangular wave}$	—	—	0.8	V
OFTR sensitivity 1	V_{OFT-S1}	$f = 470 \text{ kHz}, \text{sin wave}$ $V_{LDON} = V_{REF2} + 0.75 \text{ V}$	0	—	1.2	V
OFTR sensitivity 2	V_{OFT-S2}	$f = 130 \text{ kHz}, \text{sin wave}, V_{LDON} = V_{REF2}$	0	—	0.4	V

Note) *: The values mentioned above are subject to change according to the state of a printed circuit board, a socket, etc.

■ Electrical Characteristics at $T_a = 25^\circ\text{C}$ (continued)

Parameter	Symbol	Conditions	Min	Typ	Max	Unit
3TENV						
ENV amp. offset voltage	V_{ENVOF}	$f = 130 \text{ kHz}$, sin wave, $V_{\text{LDON}} = V_{\text{REF2}}$	-120	0	120	mV
ENV amp. operation	V_{ENV}	$V_{\text{CC1}} = 5 \text{ V}$, $V_{\text{CC2}} = 3.3 \text{ V}$ $f = 800 \text{ kHz}$, AM modulation	260	470	680	mV[p-p]
LD-APC						
LD operating reference voltage 1	V_{LD1}	$V_{\text{CC1}} = 5 \text{ V}$, $V_{\text{CC2}} = 3.3 \text{ V}$ $V_{\text{GCTL}} = V_{\text{REF2}} - 0.3 \text{ V}$	134	170	206	mV
LD operating reference voltage ratio	B_{LD}	$V_{\text{CC1}} = 5 \text{ V}$, $V_{\text{CC2}} = 3.3 \text{ V}$ $V_{\text{GCTL}} = V_{\text{REF2}} + 0.3 \text{ V}$	1.08	1.15	1.22	—
LDON operating voltage	V_{LDON}	$V_{\text{CC1}} = 5 \text{ V}$, $V_{\text{CC2}} = 3.3 \text{ V}$ $V_{\text{GCTL}} = V_{\text{REF2}} - 0.3 \text{ V}$	—	—	-0.35	V
Standby						
Current consumption with no load at standby	I_{STBY}	$V_{\text{CC1}} = 5 \text{ V}$, $V_{\text{CC2}} = 3.3 \text{ V}$ $V_{\text{LDON}} = V_{\text{REF2}} - 0.75 \text{ V}$	3.50	5.00	6.50	mA

Maintenance/Discontinued

Maintenance/Discontinued includes following four Product lifecycle stage:
(planned maintenance type, maintenance type, planned discontinued type, discontinued type)

Application Circuit Example

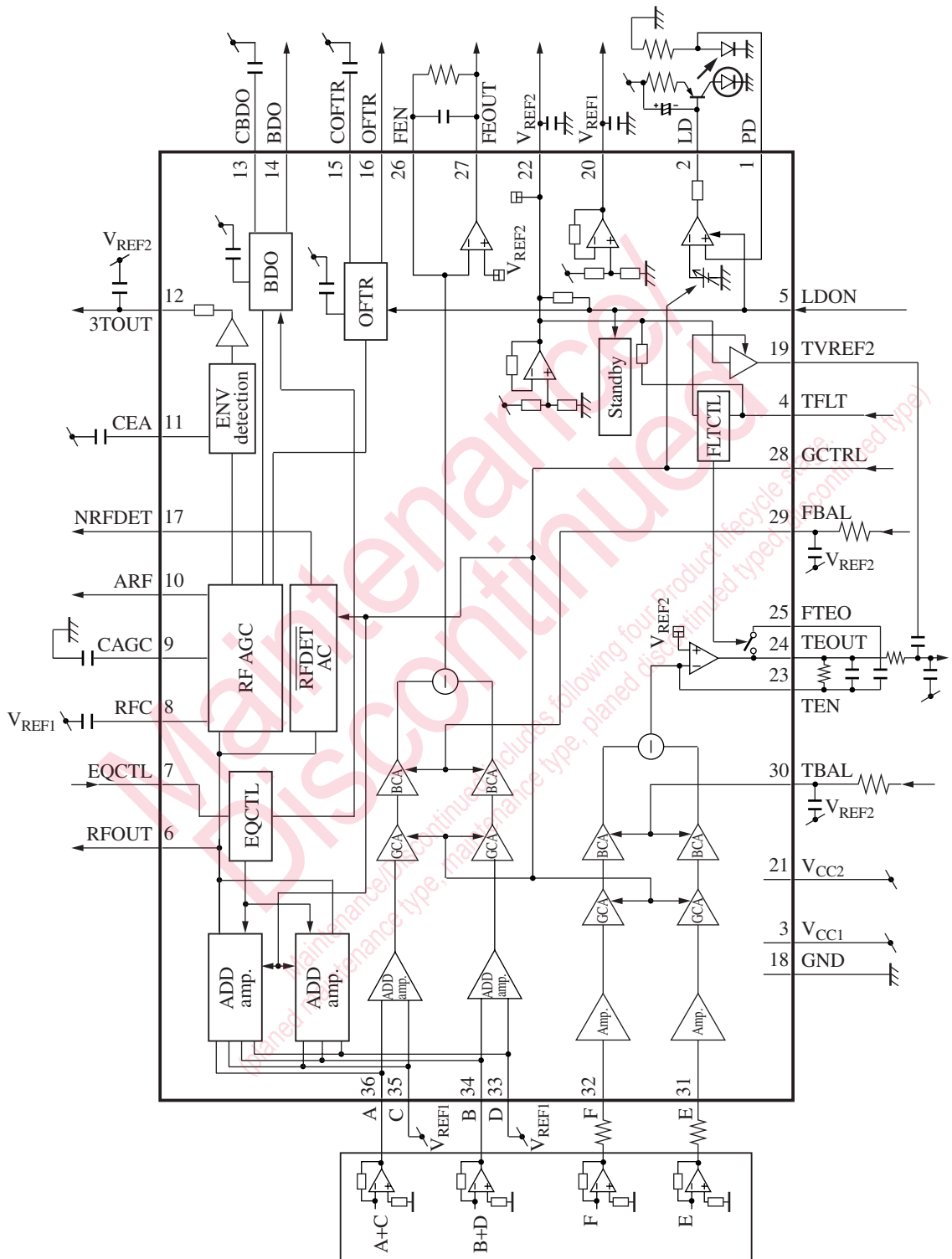

■ New Package Dimensions (Unit: mm)

- SSOP036-P-0450C (Lead-free package)

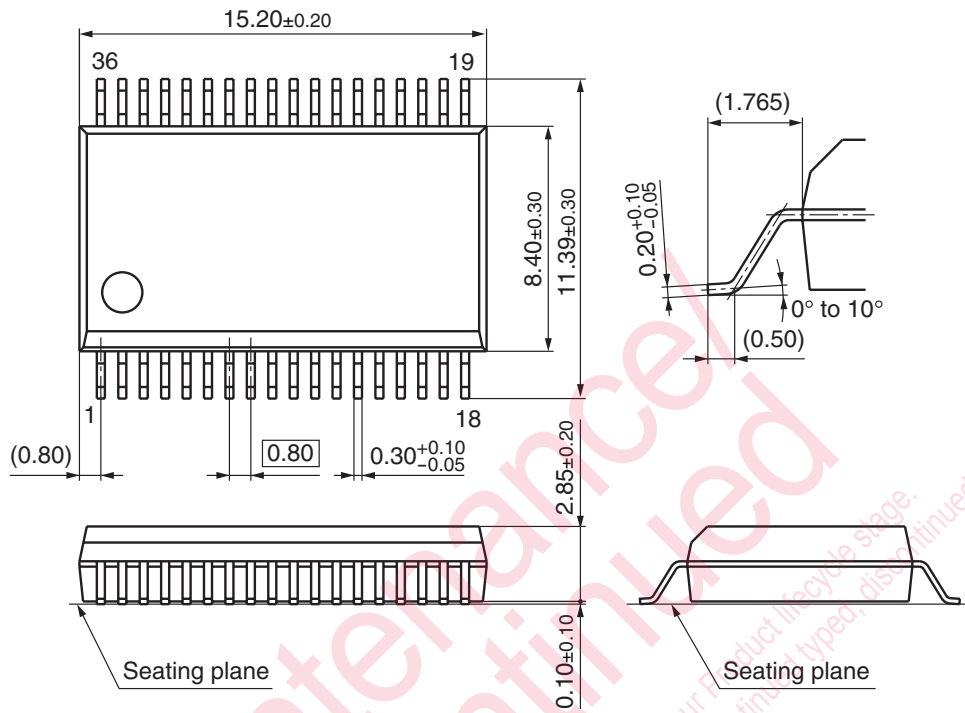

Request for your special attention and precautions in using the technical information and semiconductors described in this book

- (1) If any of the products or technical information described in this book is to be exported or provided to non-residents, the laws and regulations of the exporting country, especially, those with regard to security export control, must be observed.
- (2) The technical information described in this book is intended only to show the main characteristics and application circuit examples of the products, and no license is granted under any intellectual property right or other right owned by our company or any other company. Therefore, no responsibility is assumed by our company as to the infringement upon any such right owned by any other company which may arise as a result of the use of technical information described in this book.
- (3) The products described in this book are intended to be used for standard applications or general electronic equipment (such as office equipment, communications equipment, measuring instruments and household appliances).
Consult our sales staff in advance for information on the following applications:
 - Special applications (such as for airplanes, aerospace, automobiles, traffic control equipment, combustion equipment, life support systems and safety devices) in which exceptional quality and reliability are required, or if the failure or malfunction of the products may directly jeopardize life or harm the human body.
 - Any applications other than the standard applications intended.
- (4) The products and product specifications described in this book are subject to change without notice for modification and/or improvement. At the final stage of your design, purchasing, or use of the products, therefore, ask for the most up-to-date Product Standards in advance to make sure that the latest specifications satisfy your requirements.
- (5) When designing your equipment, comply with the range of absolute maximum rating and the guaranteed operating conditions (operating power supply voltage and operating environment etc.). Especially, please be careful not to exceed the range of absolute maximum rating on the transient state, such as power-on, power-off and mode-switching. Otherwise, we will not be liable for any defect which may arise later in your equipment.
 - Even when the products are used within the guaranteed values, take into the consideration of incidence of break down and failure mode, possible to occur to semiconductor products. Measures on the systems such as redundant design, arresting the spread of fire or preventing glitch are recommended in order to prevent physical injury, fire, social damages, for example, by using the products.
- (6) Comply with the instructions for use in order to prevent breakdown and characteristics change due to external factors (ESD, EOS, thermal stress and mechanical stress) at the time of handling, mounting or at customer's process. When using products for which damp-proof packing is required, satisfy the conditions, such as shelf life and the elapsed time since first opening the packages.
- (7) This book may be not reprinted or reproduced whether wholly or partially, without the prior written permission of Matsushita Electric Industrial Co., Ltd.