



DM54S182/DM74S182 Look-Ahead Carry Generators

General Description

These circuits are high-speed, look-ahead carry generators, capable of anticipating a carry across four binary adders or groups of adders. They are cascadable to perform full look-ahead across n-bit adders. Carry, generate-carry, and propagate-carry functions are provided as shown in the pin designation table.

When used in conjunction with the 181 arithmetic logic unit, these generators provide high-speed carry look-ahead capability for any word length. Each S182 generates the look-ahead (anticipated carry) across a group of four ALU's and, in addition, other carry look-ahead circuits may be employed to anticipate carry across sections of four look-ahead packages up to n-bits. The method of cascading circuits to perform multi-level look-ahead is illustrated under typical application data.

Carry input and output of the ALU's are in their true form, and the carry propagate (P) and carry generate (G) are in negated form; therefore, the carry functions (inputs, outputs,

generate, and propagate) of the look-ahead generators are implemented in the compatible forms for direct connection to the ALU. Reinterpretations of carry functions, as explained on the 181 data sheet are also applicable to and compatible with the look-ahead generator. Positive logic equations for the S182 are:

$$C_n + x = \bar{G}0 + \bar{P}0 C_n$$

$$C_n + y = \bar{G}1 + \bar{P}1 \bar{G}0 + \bar{P}1 \bar{P}0 C_n$$

$$C_n + z = \bar{G}2 + \bar{P}2 \bar{G}1 + \bar{P}2 \bar{P}1 \bar{G}0 + \bar{P}2 \bar{P}1 \bar{P}0 C_n$$

$$\bar{G} = \bar{G}3 (\bar{P}3 + \bar{G}2) (\bar{P}3 + \bar{P}2 + \bar{G}1)$$

$$(\bar{P}3 + \bar{P}2 + \bar{P}1 + \bar{G}0)$$

$$\bar{P} = \bar{P}3 \bar{P}2 \bar{P}1 \bar{P}0$$

Features

- Typical propagation delay time 7 ns
- Typical power dissipation 260 mW

Connection Diagram

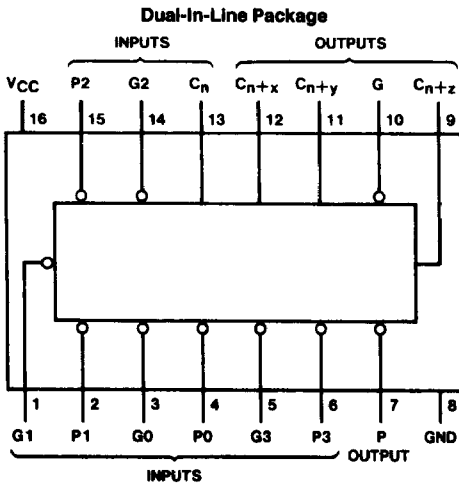

TL/F/6474-1

Order Number DM54S182J or DM74S182N
See NS Package Number J16A or N16E

Pin Designations

| Designation | Pin Nos. | Function |
|---|-------------|--------------------------------------|
| G0, G1, G2, G3 | 3, 1, 14, 5 | Active Low Carry Generate Inputs |
| P0, P1, P2, P3 | 4, 2, 15, 6 | Active Low Carry Propagate Inputs |
| C _n | 13 | Carry Input |
| C _{n + x} , C _{n + y} , C _{n + z} | 12, 11, 9 | Carry Outputs |
| G | 10 | Active Low Carry Generate Output |
| P | 7 | Active Low Carry Propagate Output |
| V _{CC} | 16 | Supply Voltage |
| GND | 8 | Ground |

Absolute Maximum Ratings (Note)

If Military/Aerospace specified devices are required, please contact the National Semiconductor Sales Office/Distributors for availability and specifications.

| | |
|--------------------------------------|-----------------|
| Supply Voltage | 7V |
| Input Voltage | 5.5V |
| Operating Free Air Temperature Range | |
| DM54S | -55°C to +125°C |
| DM74S | 0°C to +70°C |
| Storage Temperature Range | -65°C to +150°C |

Note: The "Absolute Maximum Ratings" are those values beyond which the safety of the device cannot be guaranteed. The device should not be operated at these limits. The parametric values defined in the "Electrical Characteristics" table are not guaranteed at the absolute maximum ratings. The "Recommended Operating Conditions" table will define the conditions for actual device operation.

Recommended Operating Conditions

| Symbol | Parameter | DM54S182 | | | DM74S182 | | | Units |
|-----------------|--------------------------------|----------|-----|-----|----------|-----|------|-------|
| | | Min | Nom | Max | Min | Nom | Max | |
| V _{CC} | Supply Voltage | 4.5 | 5 | 5.5 | 4.75 | 5 | 5.25 | V |
| V _{IH} | High Level Input Voltage | 2 | | | 2 | | | V |
| V _{IL} | Low Level Input Voltage | | | 0.8 | | | 0.8 | V |
| I _{OH} | High Level Output Current | | | -1 | | | -1 | mA |
| I _{OL} | Low Level Output Current | | | 20 | | | 20 | mA |
| T _A | Free Air Operating Temperature | -55 | | 125 | 0 | | 70 | °C |

Electrical Characteristics over recommended operating free air temperature (unless otherwise noted)

| Symbol | Parameter | Conditions | Min | Typ (Note 1) | Max | Units | |
|------------------|-----------------------------------|--|----------------|--------------|------|-------|----|
| V _I | Input Clamp Voltage | V _{CC} = Min, I _I = -18 mA | | | -1.2 | V | |
| V _{OH} | High Level Output Voltage | V _{CC} = Min, I _{OH} = Max V _{IL} = Max, V _{IH} = Min | | | | V | |
| | | | DM54 | 2.5 | 3.4 | | |
| | | | DM74 | 2.7 | 3.4 | | |
| V _{OL} | Low Level Output Voltage | V _{CC} = Min, I _{OL} = Max V _{IH} = Min, V _{IL} = Max | | | 0.5 | V | |
| I _I | Input Current @ Max Input Voltage | V _{CC} = Max, V _I = 5.5V | | | 1 | mA | |
| I _{IH} | High Level Input Current | V _{CC} = Max V _I = 2.7V | P0, P1 or G3 | | 200 | μA | |
| | | | P3 | | 100 | | |
| | | | P2 | | 150 | | |
| | | | C _n | | 50 | | |
| | | | G0, G2 | | 350 | | |
| | | | G1 | | 400 | | |
| I _{IL} | Low Level Input Current | V _{CC} = Max V _I = 0.5V | P0, P1 or G3 | | -8 | mA | |
| | | | P3 | | -4 | | |
| | | | P2 | | -6 | | |
| | | | C _n | | -2 | | |
| | | | G0, G2 | | -14 | | |
| | | | G1 | | -16 | | |
| I _{OS} | Short Circuit Output Current | V _{CC} = Max (Note 2) | DM54 | -40 | -100 | mA | |
| | | | DM74 | -40 | -100 | | |
| I _{COH} | Supply Current with Outputs High | V _{CC} = Max (Note 3) | DM54 | | 39 | 55 | mA |
| | | | DM74 | | 39 | 55 | |
| I _{COL} | Supply Currents with Outputs Low | V _{CC} = Max (Note 4) | DM54 | | 69 | 99 | mA |
| | | | DM74 | | 69 | 109 | |

Note 1: All typicals are at V_{CC} = 5V, T_A = 25°C.

Note 2: Not more than one output should be shorted at a time, and the duration should not exceed one second.

Note 3: I_{COH} is measured with all outputs open, inputs P3 and G3 at 4.5V, and all other inputs grounded.

Note 4: I_{COL} is measured with all outputs open, inputs G0, G1, and G2 at 4.5V, and all other inputs grounded.

Switching Characteristics at $V_{CC} = 5V$ and $T_A = 25^\circ C$ (See Section 1 for Test Waveforms and Output Load)

| Symbol | Parameter | From (Input) To (Output) | $R_L = 280\Omega$ | | | | Units |
|-----------|--|--------------------------------|----------------------|------|----------------------|-----|-------|
| | | | $C_L = 15\text{ pF}$ | | $C_L = 50\text{ pF}$ | | |
| | | | Min | Max | Min | Min | |
| t_{PLH} | Propagation Delay Time Low to High Level Output | GN or PN to $C_n + x, y, z$ | | 7 | | 10 | ns |
| t_{PHL} | Propagation Delay Time High to Low Level Output | GN or PN to $C_n + x, y, z$ | | 7 | | 11 | ns |
| t_{PLH} | Propagation Delay Time Low to High Level Output | GN or PN to G | | 7.5 | | 11 | ns |
| t_{PHL} | Propagation Delay Time High to Low Level Output | GN or PN to G | | 10.5 | | 14 | ns |
| t_{PLH} | Propagation Delay Time Low to High Level Output | PN to P | | 6.5 | | 10 | ns |
| t_{PHL} | Propagation Delay Time High to Low Level Output | PN to P | | 10 | | 14 | ns |
| t_{PLH} | Propagation Delay Time Low to High Level Output | C_n to to $C_n + x, y, z$ | | 10 | | 13 | ns |
| t_{PHL} | Propagation Delay Time High to Low Level Output | C_n to to $C_n + x, y, z$ | | 10.5 | | 14 | ns |

Logic Diagram

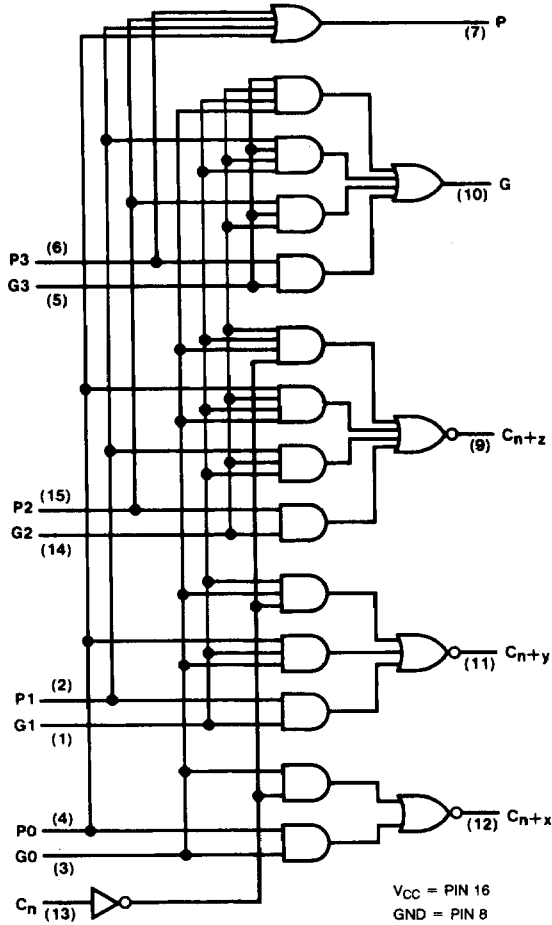

TL/F/8474-2

Typical Application

64-Bit ALU, Full-Carry Look Ahead In Three Levels

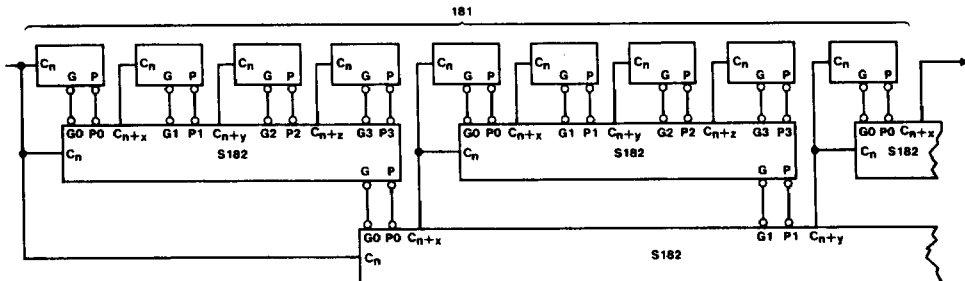

TL/F/8474-3

A and B inputs, and F outputs of 181 are not shown.