

5050-0021

NOTES

1. MATING:
Interface dimensions per Mil-C-39012/N Series and Solitron/Microwave MD-109.
2. MATERIALS:
Body:-----Brass per QQ-B-626, 1/2 Hard, Alloy 360.
Contact:-----Beryllium Copper per QQ-C-530, Cond. H., Alloy 173.
Dielectric:----Teflon per Mil-P-19468 and L-P-403, Type 1.
3. FINISH:
Body:-----Gold per Mil-G-45204, Type II Grade C, Class 1; over copper per Mil-C-14550, Class 4.
Contact:-----Gold per Mil-G-45204, Type II, Grade C, Class 2; over Copper per Mil-C-14550, Class 4.
4. Contact Epoxy Captivated.

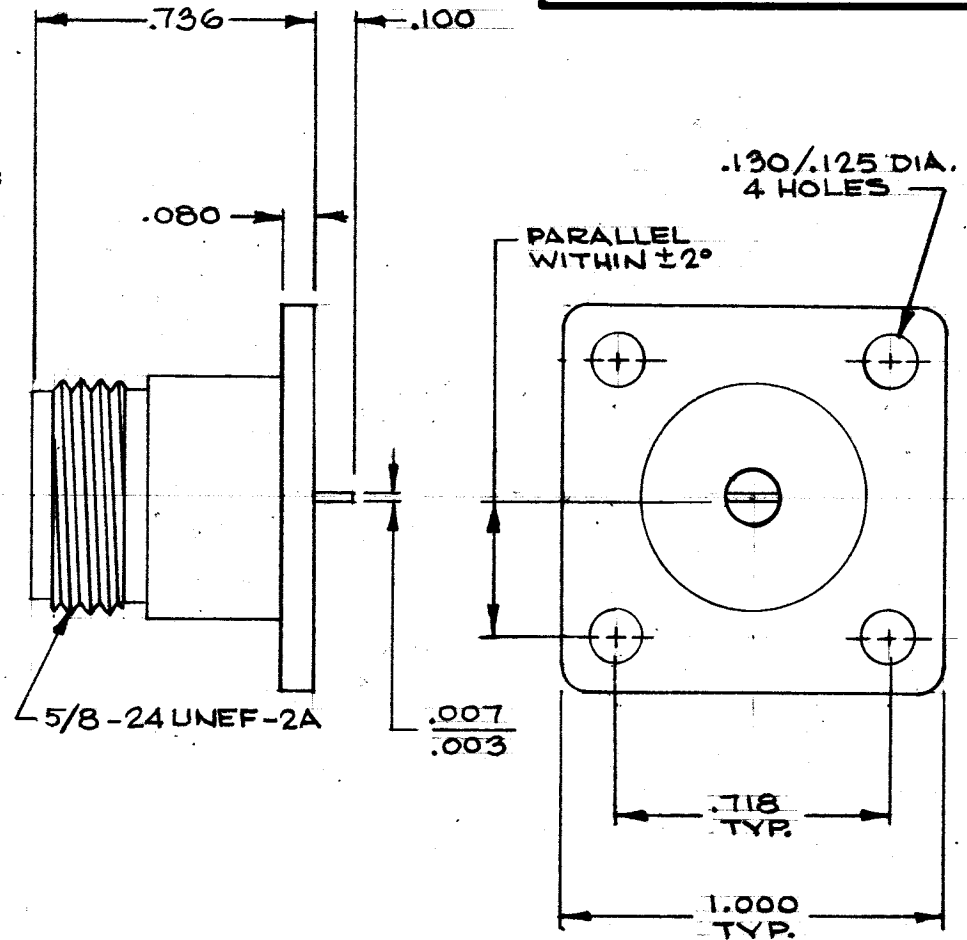

SYM	DESCRIPTION	DATE	APPR.	UNLESS OTHERWISE SPECIFIED:			SOLITRON/MICROWAVE		REF.		
				1. ALL DIMENSIONS ARE AFTER PLATING 2. BREAK ALL CORNERS & EDGES .005 R MAX. 3. CHAMFER 1ST & LAST THREADS 45° 4. SURFACE ROUGHNESS 63 ✓ MIL-STD-10 5. DIAMETERS ON COMMON CENTERS TO BE CONCENTRIC WITHIN T.I.R. 6. REMOVE ALL BURRS			PORT SALERNO, FLORIDA		ENGINEERING DATA DRAWING		
-	REL. DCN F-9351	6/83	RD	DIMENSIONS ARE IN INCHES TOLERANCES			MATERIAL		TITLE		
				DECIMALS	FRACTIONAL	ANGULAR	FINISH		AREA		
				.X ± .030		X' ± 1'0"	-		-		
				.XX ± .015	± 1/64	X'X' ± 15'					
				.XXX ± .005							
				DRAWN R.P.A. DATE 6-17-83			SCALE	CODE IDENT. NO.	SIZE	DRAWING NO.	
				CHECKED RG DATE 6-20-83			-	95077	A	5050-0021	
				APPROVED ND DATE 6-22-83						SHEET 1 OF 2	

ENG. FILE COPY

S/M DESIGN STANDARDS

DRAWING NO.

5050-0021

REQUIREMENTS	RATINGS	REQUIREMENTS	RATINGS
Nominal Impedance (ohms)	50	Vibration	MIL-STD-202 Method 204 Cond. D (20G's)
Frequency Range (ghz)	DC-12.4	Shock	MIL-STD-202 Method 213 Cond. I (100G's)
Voltage Rating (max. vrms)	1000	Temperature Cycling	MIL-STD-202 Method 102 - Cond. C (-65°C to + 200 ° C)
Temperature Rating (degrees centigrade)	-65 To +165	Corrosion	MIL-STD-202 Method 101 Cond. B (48 Hrs.)
VSWR (max.) 2)	1.07+.007 xFGHZ	Moisture Resistance	MIL-STD-202 Method 106 Less Step 7b
Insertion Loss (dB max.) 2)	.06x√FGHZ	Barometric Pressure (Altitude)	MIL-STD-202 Method 105 - Cond. C (70,000 ft) (750 vrms)
RF Leakage (min. dB down)	60 dB-FGHZ	Captivation Center Contact (Min. Axial Force) (Min. Radial Force)	10.0 lbs. 4 IN.OZ.
RF High Potential (max. vrms)	2000 at 5MHz		
Dielectric Withstanding Voltage (max. vrms)	3000		
Insulation Resistance (min. megohms)	5000		
Contact Resistance:			
Center Contact (max. milliohms)	1.0		
Outer Contact (max. milliohms)	0.2		
Center Contact Axial Forces:			
Insertion (max. ounces)	24.0		
Withdrawal (min. ounces)	2.0		
Connector Durability (min. cycles)	500		
Connector Engagement & Disengagement (max. inch lbs.)	6.0		

REMARKS: 1) Recommended Mating Torque: 35-40 inch pounds.
2) When properly terminated in a 50 ohm load.

TITLE: N JACK, 4 HOLE FLANGE MOUNT
TAB CONTACT

SOLITRON/MICROWAVE
PORT SALERNO, FLORIDA

SHT. 2 of 2

DRAWING NO.
5050 - 0021

REV.
-