

240-800
Series 800 Mighty Mouse Filter Receptacle Connector
UN Mating Threads, Square Flange or Jam Nut



Contact Arrangements					
Contact Arr.	No. of Contacts				
	#23	#20	#20HD	#16	#12
5-3	3				
6-1				1	
6-23			3		
6-4	4				
6-6	6				
6-7	7				
7-1					1
7-25			5		
7-10	10				
8-2				2	
8-28			8		
8-13	13				
8-200	4	2			
9-4				4	
9-210			10		
9-19	19				
9-200	4			2	
9-201	8	2			
10-2					2
10-5				5	
10-26	26				
10-200	12				1
10-201	4				2
10-202	8			2	
12-2					2
12-3					3
12-7				7	
12-220			20		
12-37	37				
12-200	6				2
12-201	10				2

Table II: Connector Class		
Sym	Material	Finish Description
M	Aluminum	Electroless Nickel
MT		Ni-PTFE 1000 Hour Grey™ Nickel Fluorocarbon Polymer
NF		Cadmium, Olive Drab over Electroless Nickel
ZN		Zinc-Nickel, Olive Drab
ZR		Zinc-Nickel, Black - RoHS
ZL	Stainless Steel	Electro-Deposited Nickel

Table III: Capacitor Array Code Capacitance Range		
Class	Pi - Circuit (pF)	C - Circuit (pF)
A	38,000 - 56,000	19,000 - 28,000
B	32,000 - 45,000	16,000 - 22,500
C	18,000 - 33,000	9,000 - 16,500
D	8,000 - 12,000	4,000 - 6,000
E	3,300 - 5,000	1,650 - 2,500
F	800 - 1,300	400 - 650
G	400 - 600	200 - 300
J	70 - 120	35 - 60

Table IV: PC Tail Dia	
Contact Size	Ø U
23	.022 (0.56)
	.018 (0.46)
20	.028 (0.71)
	.024 (0.61)
16	.042 (1.07)
	.038 (0.97)
12	.096 (2.44)
	.092 (2.34)

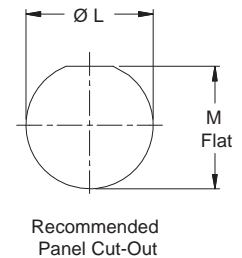
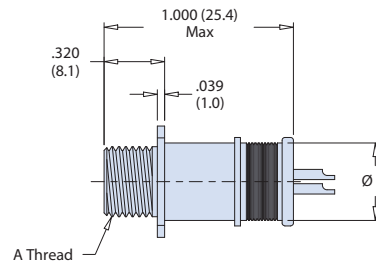
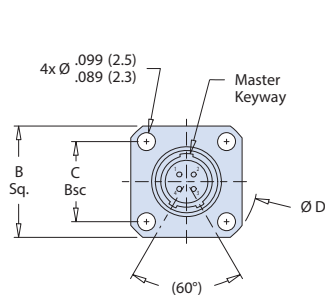
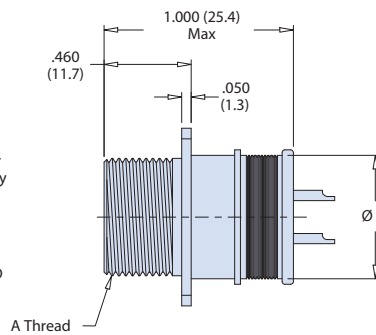
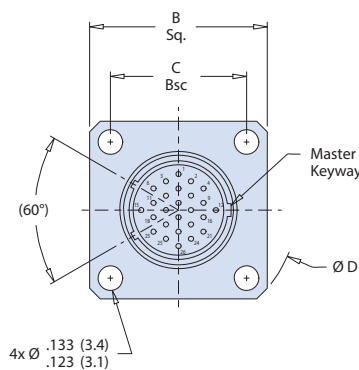

Table V: Dimensions										
Shell Size	A Thread	B Sq.	C Bsc	Ø D	Ø E	Ø G	H Flat	J Flat	Ø L ±.003 (0.05)	M Flat ±.005 (0.13)
5	.3125-28 UN-2A	.527 (13.4)	.363 (9.2)	.680 (17.3)	.365 (9.3)	.541 (13.7)	.500 (12.7)	.285 (7.2)	.297 (7.54)	.322 (8.18)
6	.3750-28 UN-2A	.588 (14.9)	.423 (10.7)	.750 (19.1)	.409 (10.4)	.610 (15.5)	.562 (14.3)	.352 (8.9)	.360 (9.14)	.385 (9.78)
7	.4375-28 UNEF-2A	.650 (16.5)	.483 (12.3)	.830 (21.1)	.500 (12.7)	.670 (17.0)	.635 (16.1)	.411 (10.4)	.426 (10.82)	.447 (11.35)
8	.5000-32 UN-2A	.710 (18.0)	.542 (13.8)	.938 (23.8)	.522 (13.3)	.775 (19.7)	.735 (18.7)	.473 (12.0)	.481 (12.22)	.510 (12.95)
9	.5625-32 UN-2A	.938 (23.8)	.719 (18.3)	1.250 (31.8)	.610 (15.5)	.875 (22.2)	.806 (20.5)	.530 (13.5)	.539 (13.69)	.572 (14.53)
10	.6250-32 UN-2A	.938 (23.8)	.719 (18.3)	1.250 (31.8)	.652 (16.6)	.980 (24.9)	.940 (23.9)	.604 (15.3)	.612 (15.54)	.635 (16.13)
12	.7500-28 UN-2A	1.031 (26.2)	.812 (20.6)	1.375 (34.9)	.746 (18.9)	1.062 (27.0)	.986 (25.0)	.712 (18.1)	.719 (18.26)	.760 (19.30)

Dimensions in inches (millimeters) and are subject to change without notice.



-01 Solder Cup
Sq. Flange Mount
Shell Sizes 5 & 6



-01 Solder Cup
Sq. Flange Mount
Shell Sizes 7 - 12

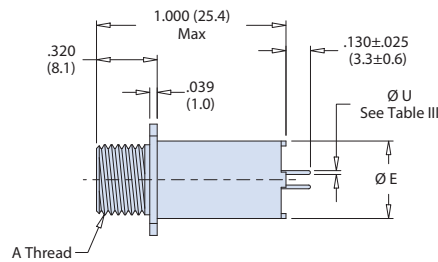
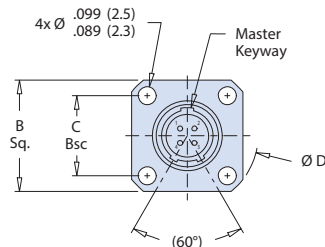

-02 PC Tail
Sq. Flange Mount
Shell Sizes 5 & 6

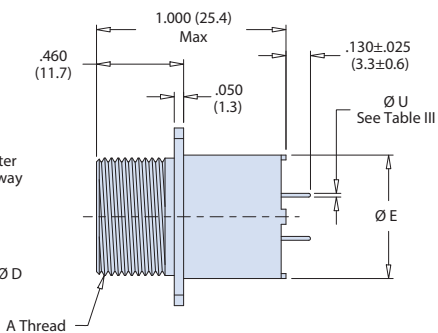
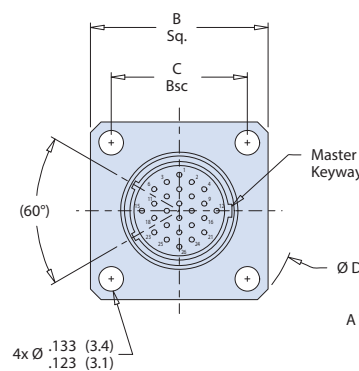

-02 PC Tail
Sq. Flange Mount
Shell Sizes 7 - 12

Dimensions in inches (millimeters) and are subject to change without notice.

240-800
Series 800 Mighty Mouse Filter Receptacle Connector
 UN Mating Threads, Jam Nut



Mighty Mouse

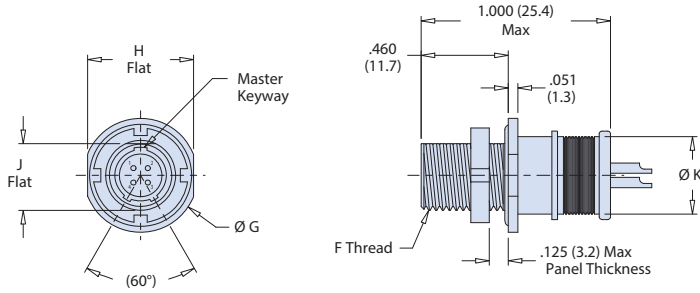

-07 Solder Cup
 Jam Nut Mount
 Shell Sizes 5 & 6

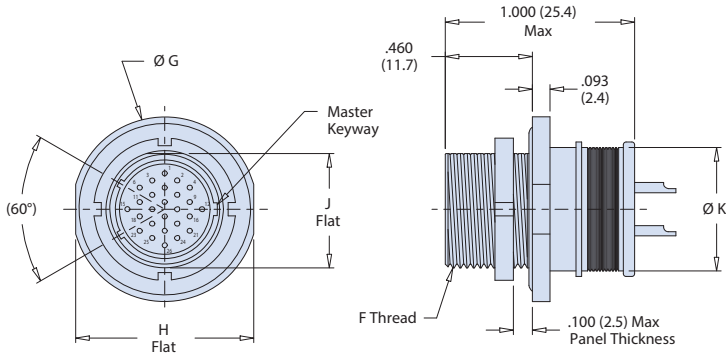

-07 Solder Cup
 Jam Nut Mount
 Shell Sizes 7 - 12

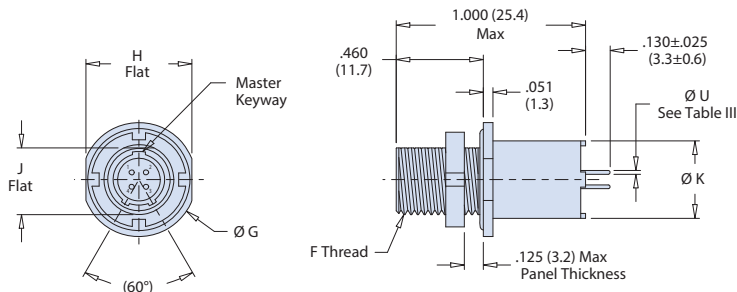

-08 PC Tail
 Jam Nut Mount
 Shell Sizes 5 & 6

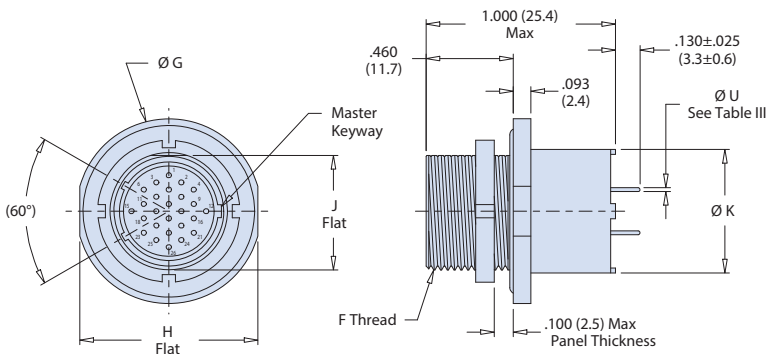

-08 PC Tail
 Jam Nut Mount
 Shell Sizes 7 - 12

Dimensions in inches (millimeters) and are subject to change without notice.

C