

## Low Power Quint Exclusive OR/NOR Gate

### General Description

The 100307 is monolithic quint exclusive-OR/NOR gate. The Function output is the wire-OR of all five exclusive-OR outputs. All inputs have 50 kΩ pull-down resistors.

### Features

- Low Power Operation
- 2000V ESD protection
- Pin/function compatible with 100107
- Voltage compensated operating range = -4.2V to -5.7V
- Available to industrial grade temperature range
- Available to Standard Microcircuit Drawing (SMD) 5962-9459001

### Logic Symbol

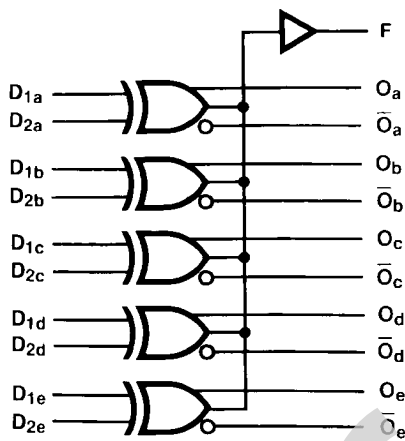

### Logic Equation

$$F = (D_{1a} + D_{2a}) + (D_{1b} + D_{2b}) + (D_{1c} + D_{2c}) + (D_{1d} + D_{2d}) + (D_{1e} + D_{2e})$$

Pin Names	Description
$D_{na}-D_{ne}$	Data Inputs
F	Function Output
$O_a-O_e$	Data Outputs
$\bar{O}_a-\bar{O}_e$	Complementary Data Outputs

# Connection Diagrams

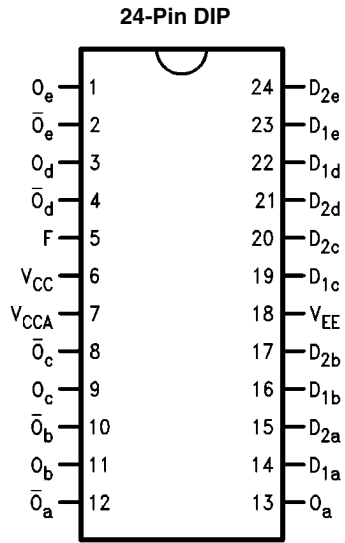

10030502

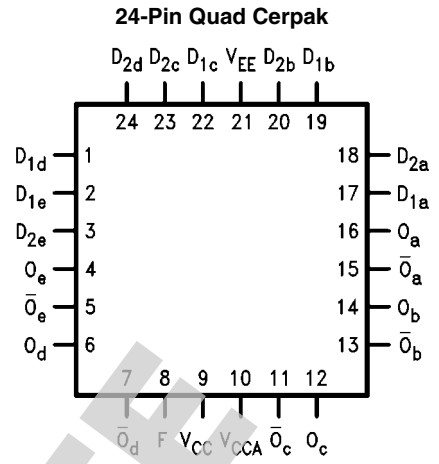

10030503

OBSOLETE

## Absolute Maximum Ratings (Note 1)

If Military/Aerospace specified devices are required, please contact the National Semiconductor Sales Office/Distributors for availability and specifications.

Above which the useful life may be impaired. (Note 1)

Storage Temperature ( $T_{STG}$ )	-65°C to +150°C
Maximum Junction Temperature ( $T_J$ )	
Ceramic	+175°C
Plastic	+150°C
$V_{EE}$ Pin Potential to Ground Pin	-7.0V to +0.5V
Input Voltage (DC)	$V_{EE}$ to +0.5V

Output Current (DC Output HIGH)	-50 mA
ESD (Note 2)	≥2000V

## Recommended Operating Conditions

Case Temperature ( $T_C$ )	
Military	-55°C to +125°C
Supply Voltage ( $V_{EE}$ )	-5.7V to -4.2V

**Note 1:** Absolute maximum ratings are those values beyond which the device may be damaged or have its useful life impaired. Functional operation under these conditions is not implied.

**Note 2:** ESD testing conforms to MIL-STD-883, Method 3015.

## Military Version DC Electrical Characteristics

$V_{EE} = -4.2V$  to  $-5.7V$ ,  $V_{CC} = V_{CCA} = GND$ ,  $T_C = -55°C$  to  $+125°C$

Symbol	Parameter	Min	Max	Units	$T_C$	Conditions	Notes	
$V_{OH}$	Output HIGH Voltage	-1025	-870	mV	0°C to +125°C	$V_{IN} = V_{IH} (Max)$ or $V_{IL} (Min)$	Loading with 50Ω to -2.0V	1, 2, 3
		-1085	-870	mV	-55°C			
$V_{OL}$	Output LOW Voltage	-1830	-1620	mV	0°C to +125°C	$V_{IN} = V_{IH} (Min)$ or $V_{IL} (Max)$	Loading with 50Ω to -2.0V	1, 2, 3
		-1830	-1555	mV	-55°C			
$V_{OHC}$	Output HIGH Voltage	-1035		mV	0°C to +125°C	$V_{IN} = V_{IH} (Min)$ or $V_{IL} (Max)$	Loading with 50Ω to -2.0V	1, 2, 3
		-1085		mV	-55°C			
$V_{OLC}$	Output LOW Voltage		-1610	mV	0°C to +125°C	$V_{IN} = V_{IH} (Min)$ or $V_{IL} (Max)$	Loading with 50Ω to -2.0V	1, 2, 3
			-1555	mV	-55°C			
$V_{IH}$	Input HIGH Voltage	-1165	-870	mV	-55°C to +125°C	Guaranteed HIGH Signal for All Inputs	1, 2, 3, 4	
$V_{IL}$	Input LOW Voltage	-1830	-1475	mV	-55°C to +125°C	Guaranteed LOW Signal for All Inputs	1, 2, 3, 4	
$I_{IL}$	Input LOW Current	0.50		μA	-55°C to +125°C	$V_{EE} = -4.2V$ $V_{IN} = V_{IL} (Min)$	1, 2, 3	
$I_{IH}$	Input High Current	$D_{2a}-D_{2e}$ $D_{1a}-D_{1e}$	250	μA	0°C to +125°C	$V_{EE} = -5.7V$ $V_{IN} = V_{IH} (Max)$	1, 2, 3	
			350	μA	-55°C			
		$D_{2a}-D_{2e}$ $D_{1a}-D_{1e}$	350	μA	-55°C	$V_{EE} = -5.7V$ $V_{IN} = V_{IH} (Max)$		
			500	μA	-55°C			
$I_{EE}$	Power Supply Current	-75	-25	mA	-55°C to +125°C	Inputs Open	1, 2, 3	

**Note 3:** F100K 300 Series cold temperature testing is performed by temperature soaking (to guarantee junction temperature equals -55°C), then testing immediately without allowing for the junction temperature to stabilize due to heat dissipation after power-up. This provides "cold start" specs which can be considered a worst case condition at cold temperatures.

**Note 4:** Screen tested 100% on each device at -55°C, +25°C, and +125°C, Subgroups 1, 2, 3, 7, and 8.

**Note 5:** Sample tested (Method 5005, Table I) on each manufactured lot at -55°C, +25°C, and +125°C, Subgroups A1, 2, 3, 7, and 8.

**Note 6:** Guaranteed by applying specified input condition and testing  $V_{OH}/V_{OL}$ .

## AC Electrical Characteristics

$V_{EE} = -4.2V$  to  $-5.7V$ ,  $V_{CC} = V_{CCA} = GND$

Symbol	Parameter	$T_C = -55^\circ C$		$T_C = +25^\circ C$		$T_C = +125^\circ C$		Units	Conditions	Notes
		Min	Max	Min	Max	Min	Max			
$t_{PLH}$	Propagation Delay	0.30	2.10	0.40	1.90	0.40	2.40	ns	Figures 1, 2	1, 2, 3
$t_{PHL}$	$D_{2a}-D_{2e}$ to O, $\bar{O}$									
$t_{PLH}$	Propagation Delay	0.30	1.90	0.40	1.80	0.40	2.20	ns		
$t_{PHL}$	$D_{1a}-D_{1e}$ to O, $\bar{O}$									
$t_{PLH}$	Propagation Delay	0.80	2.90	0.90	2.80	0.90	3.40	ns		
$t_{PHL}$	Data to F									
$t_{TLH}$	Transition Time	0.20	1.70	0.30	1.60	0.20	1.70	ns		4
$t_{THL}$	20% to 80%, 80% to 20%									

**Note 7:** F100K 300 Series cold temperature testing is performed by temperature soaking (to guarantee junction temperature equals  $-55^\circ C$ ), then testing immediately after power-up. This provides "cold start" specs which can be considered a worst case condition at cold temperatures.

**Note 8:** Screen tested 100% on each device at  $+25^\circ C$  temperature only, Subgroup A9.

**Note 9:** Sample tested (Method 5005, Table I) on each mfg. lot at  $+25^\circ C$ , Subgroup A9, and at  $+125^\circ C$  and  $-55^\circ C$  temperatures, Subgroups A10 and A11.

**Note 10:** Not tested at  $+25^\circ C$ ,  $+125^\circ C$ , and  $-55^\circ C$  temperature (design characterization data).

## Test Circuitry

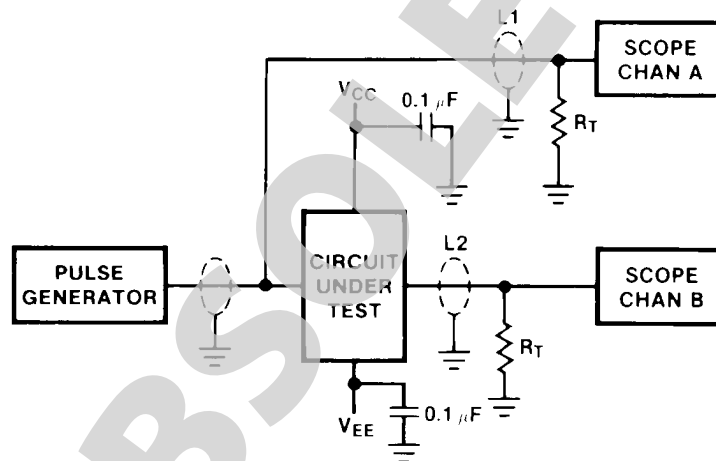

10030505

### Notes:

$V_{CC}, V_{CCA} = +2V$ ,  $V_{EE} = -2.5V$

$L1$  and  $L2$  = equal length  $50\Omega$  impedance lines

$R_T = 50\Omega$  terminator internal to scope

Decoupling  $0.1 \mu F$  from GND to  $V_{CC}$  and  $V_{EE}$

All unused outputs are loaded with  $50\Omega$  to GND

$C_L$  = Fixture and stray capacitance  $\leq 3$  pF

FIGURE 1. AC Test Circuit

# Switching Waveforms

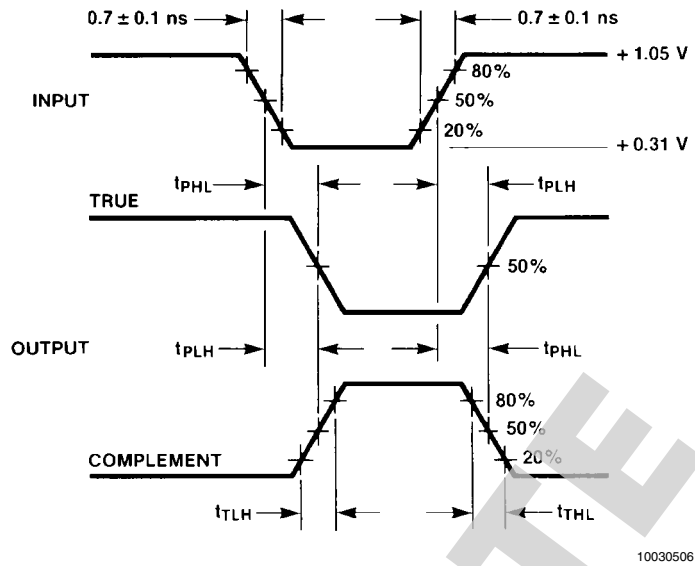
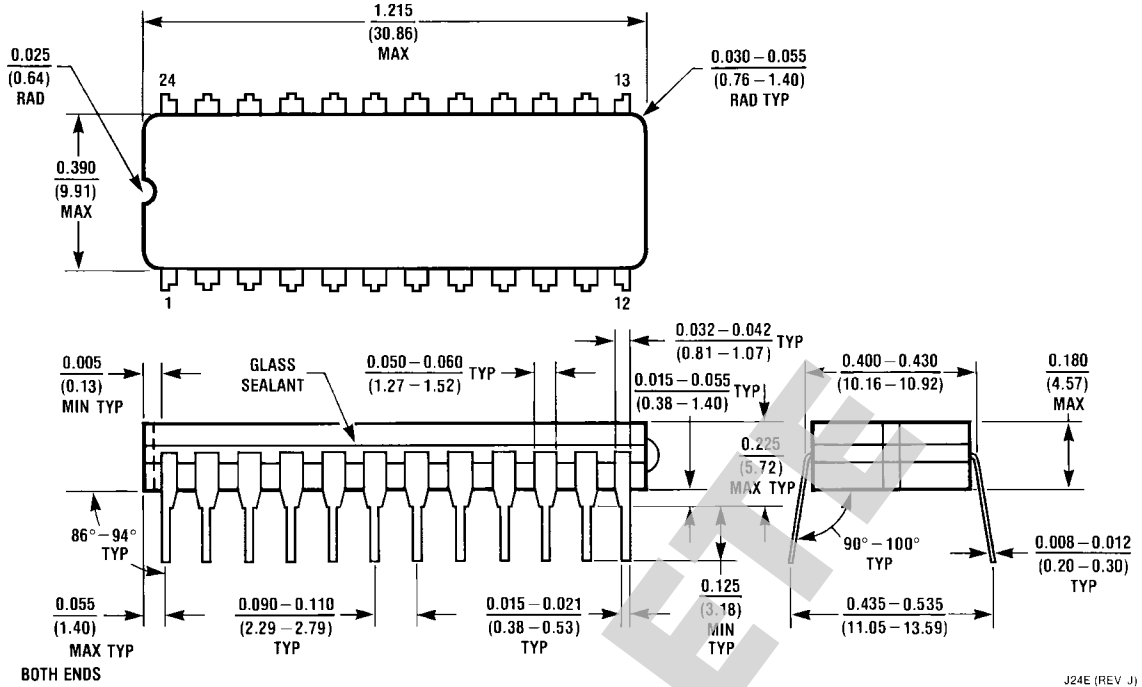

FIGURE 2. Propagation Delay and Transition Times

**Physical Dimensions** inches (millimeters) unless otherwise noted



**24-Pin Ceramic Dual-In-Line Package (D)**  
NS Package Number J24E

J24E (REV J)

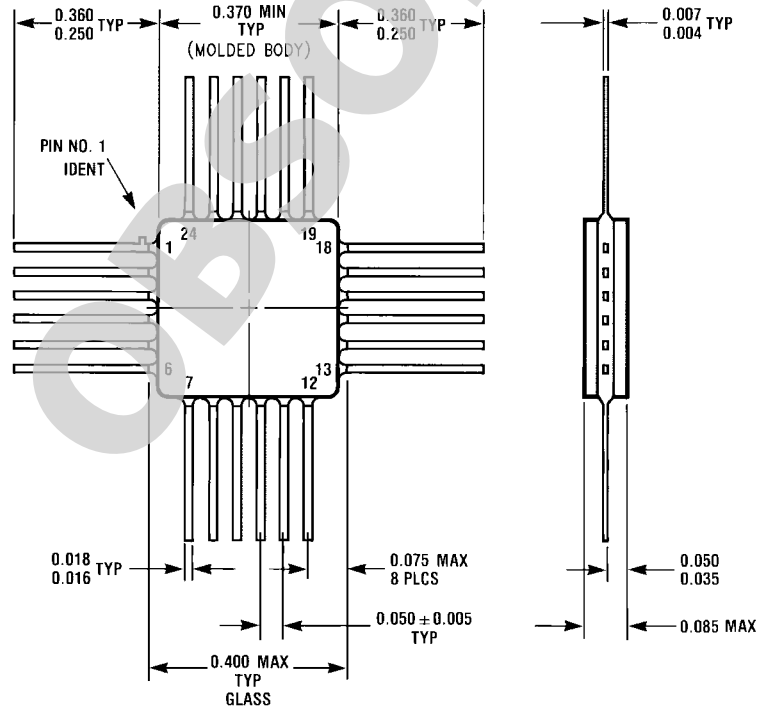

**24-Pin Quad Cerpak (F)**  
NS Package Number W24B

W24B (REV D)

# Notes

100307

**OBSOLETE**

## Notes

For more National Semiconductor product information and proven design tools, visit the following Web sites at:

Products		Design Support	
Amplifiers	<a href="http://www.national.com/amplifiers">www.national.com/amplifiers</a>	WEBENCH® Tools	<a href="http://www.national.com/webench">www.national.com/webench</a>
Audio	<a href="http://www.national.com/audio">www.national.com/audio</a>	App Notes	<a href="http://www.national.com/appnotes">www.national.com/appnotes</a>
Clock and Timing	<a href="http://www.national.com/timing">www.national.com/timing</a>	Reference Designs	<a href="http://www.national.com/refdesigns">www.national.com/refdesigns</a>
Data Converters	<a href="http://www.national.com/adc">www.national.com/adc</a>	Samples	<a href="http://www.national.com/samples">www.national.com/samples</a>
Interface	<a href="http://www.national.com/interface">www.national.com/interface</a>	Eval Boards	<a href="http://www.national.com/evalboards">www.national.com/evalboards</a>
LVDS	<a href="http://www.national.com/lvds">www.national.com/lvds</a>	Packaging	<a href="http://www.national.com/packaging">www.national.com/packaging</a>
Power Management	<a href="http://www.national.com/power">www.national.com/power</a>	Green Compliance	<a href="http://www.national.com/quality/green">www.national.com/quality/green</a>
Switching Regulators	<a href="http://www.national.com/switchers">www.national.com/switchers</a>	Distributors	<a href="http://www.national.com/contacts">www.national.com/contacts</a>
LDOs	<a href="http://www.national.com/ldo">www.national.com/ldo</a>	Quality and Reliability	<a href="http://www.national.com/quality">www.national.com/quality</a>
LED Lighting	<a href="http://www.national.com/led">www.national.com/led</a>	Feedback/Support	<a href="http://www.national.com/feedback">www.national.com/feedback</a>
Voltage Reference	<a href="http://www.national.com/vref">www.national.com/vref</a>	Design Made Easy	<a href="http://www.national.com/easy">www.national.com/easy</a>
PowerWise® Solutions	<a href="http://www.national.com/powerwise">www.national.com/powerwise</a>	Solutions	<a href="http://www.national.com/solutions">www.national.com/solutions</a>
Serial Digital Interface (SDI)	<a href="http://www.national.com/sdi">www.national.com/sdi</a>	Mil/Aero	<a href="http://www.national.com/milaero">www.national.com/milaero</a>
Temperature Sensors	<a href="http://www.national.com/tempensors">www.national.com/tempensors</a>	SolarMagic™	<a href="http://www.national.com/solarmagic">www.national.com/solarmagic</a>
Wireless (PLL/VCO)	<a href="http://www.national.com/wireless">www.national.com/wireless</a>	PowerWise® Design University	<a href="http://www.national.com/training">www.national.com/training</a>

THE CONTENTS OF THIS DOCUMENT ARE PROVIDED IN CONNECTION WITH NATIONAL SEMICONDUCTOR CORPORATION ("NATIONAL") PRODUCTS. NATIONAL MAKES NO REPRESENTATIONS OR WARRANTIES WITH RESPECT TO THE ACCURACY OR COMPLETENESS OF THE CONTENTS OF THIS PUBLICATION AND RESERVES THE RIGHT TO MAKE CHANGES TO SPECIFICATIONS AND PRODUCT DESCRIPTIONS AT ANY TIME WITHOUT NOTICE. NO LICENSE, WHETHER EXPRESS, IMPLIED, ARISING BY ESTOPPEL OR OTHERWISE, TO ANY INTELLECTUAL PROPERTY RIGHTS IS GRANTED BY THIS DOCUMENT.

TESTING AND OTHER QUALITY CONTROLS ARE USED TO THE EXTENT NATIONAL DEEMS NECESSARY TO SUPPORT NATIONAL'S PRODUCT WARRANTY. EXCEPT WHERE MANDATED BY GOVERNMENT REQUIREMENTS, TESTING OF ALL PARAMETERS OF EACH PRODUCT IS NOT NECESSARILY PERFORMED. NATIONAL ASSUMES NO LIABILITY FOR APPLICATIONS ASSISTANCE OR BUYER PRODUCT DESIGN. BUYERS ARE RESPONSIBLE FOR THEIR PRODUCTS AND APPLICATIONS USING NATIONAL COMPONENTS. PRIOR TO USING OR DISTRIBUTING ANY PRODUCTS THAT INCLUDE NATIONAL COMPONENTS, BUYERS SHOULD PROVIDE ADEQUATE DESIGN, TESTING AND OPERATING SAFEGUARDS.

EXCEPT AS PROVIDED IN NATIONAL'S TERMS AND CONDITIONS OF SALE FOR SUCH PRODUCTS, NATIONAL ASSUMES NO LIABILITY WHATSOEVER, AND NATIONAL DISCLAIMS ANY EXPRESS OR IMPLIED WARRANTY RELATING TO THE SALE AND/OR USE OF NATIONAL PRODUCTS INCLUDING LIABILITY OR WARRANTIES RELATING TO FITNESS FOR A PARTICULAR PURPOSE, MERCHANTABILITY, OR INFRINGEMENT OF ANY PATENT, COPYRIGHT OR OTHER INTELLECTUAL PROPERTY RIGHT.

#### LIFE SUPPORT POLICY

**NATIONAL'S PRODUCTS ARE NOT AUTHORIZED FOR USE AS CRITICAL COMPONENTS IN LIFE SUPPORT DEVICES OR SYSTEMS WITHOUT THE EXPRESS PRIOR WRITTEN APPROVAL OF THE CHIEF EXECUTIVE OFFICER AND GENERAL COUNSEL OF NATIONAL SEMICONDUCTOR CORPORATION.** As used herein:

Life support devices or systems are devices which (a) are intended for surgical implant into the body, or (b) support or sustain life and whose failure to perform when properly used in accordance with instructions for use provided in the labeling can be reasonably expected to result in a significant injury to the user. A critical component is any component in a life support device or system whose failure to perform can be reasonably expected to cause the failure of the life support device or system or to affect its safety or effectiveness.

National Semiconductor and the National Semiconductor logo are registered trademarks of National Semiconductor Corporation. All other brand or product names may be trademarks or registered trademarks of their respective holders.

Copyright© 2009 National Semiconductor Corporation

For the most current product information visit us at [www.national.com](http://www.national.com)



[www.national.com](http://www.national.com)

**National Semiconductor  
Americas Technical  
Support Center**

Email: [support@nsc.com](mailto:support@nsc.com)  
Tel: 1-800-272-9959

**National Semiconductor Europe  
Technical Support Center**

Email: [europe.support@nsc.com](mailto:europe.support@nsc.com)

**National Semiconductor Asia  
Pacific Technical Support Center**

Email: [ap.support@nsc.com](mailto:ap.support@nsc.com)

**National Semiconductor Japan  
Technical Support Center**

Email: [jpn.feedback@nsc.com](mailto:jpn.feedback@nsc.com)